

# LINVOL

Every journey for better arrival



MIDEA BUILDING TECHNOLOGY ELEVATOR PRODUCT COMPANY

WEB: <http://www.winone.com.cn> <https://mbtbuilding.midea.com>

This book is a tool for salespeople and reserves the right to change product designs and descriptions at any time.  
The copyright of this book belongs to Midea Building Technology. It may not be reproduced, copied or used for other purposes without permission.  
Midea Building Technology will reserve the right to pursue corresponding legal responsibilities.

Edit by Champ Liu, Eric Huang, Kid Chai  
Contact: +86 18807606205



202401-LJL





# MIDEA GROUP

ToC and ToB businesses are on par, and innovative businesses are growing rapidly

## About Company

Midea specializes in air treatment, refrigeration, laundry, large cooking appliances, large and small kitchen appliances, water appliances, floor care and lighting, and also extend to elevator business.

**\$51.39 B**

Total Revenue

**166.000+**

Employees

**278<sup>th</sup>**

On the Fortune Global 500

**200+**

Countries & Regions of Operation

**LINVOL  
WINONE**

## Smart Home Business Division



Provide the best experience in the entire Smart Home and Services



## Innovative business

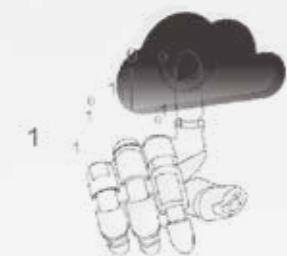

Enterprises in digital transformation and transformationIncubated new business



## Industrial Technology Division



For smart transportation, industrial automation, green energyProvide core component solutions and services in the field of consumer electronics



## ★ Building Technology Division



Provide overall solutions and services for building construction



## Robotics and Automation Division



The cornerstone of intelligent manufacturingRobot based automation solutions





# CERTIFICATE



China Top 10 Elevator



User Satisfaction Enterprise Grade A

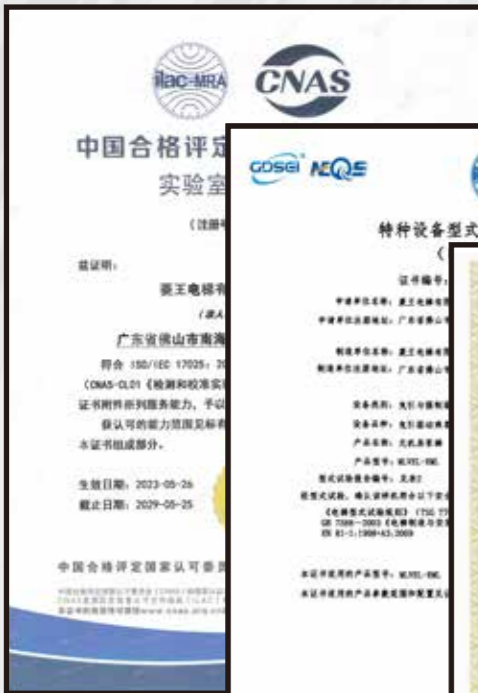

CNAS Lab Certificate



Chinese GB Type Test Certificate



Russian EAC Certificate



Russian EAC Certificate

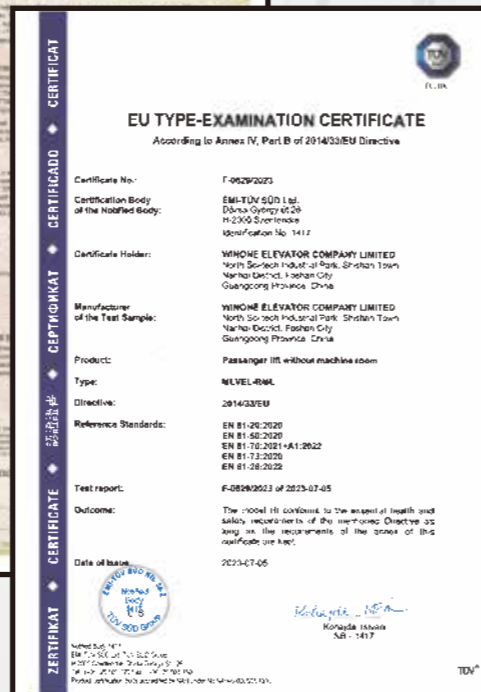

European CE Certificate



European CE Certificate



ISO 9001



ISO 14001



ISO 45001

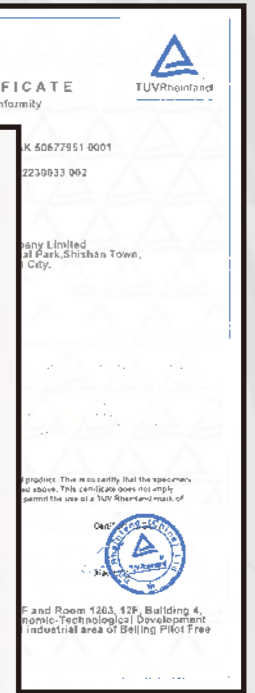

TUV Rheinland Energy Efficiency Certificate



## BRAND INTRODUCTION

Linvol elevator is a professional digital elevator brand under the building technology division of Midea Group. Lin is derived from English link, which represents seamless connection, connecting people with technology, and connecting you with your destination; Vol is from the Italian word volare, which stands for spreading wings and flying. Linvol means that we can safely and reliably take you to destinations and highlands around the world.

Relying on Midea building technology, in the field of global smart buildings, Linvol focuses on the size R & D innovation and service practice ability of building digital service platform, as well as the foundation of elevator equipment hardware manufacturing and production capacity, and deeply focuses on elevator control technology, electronic security technology, digital elevator control platform and intelligent operation service platform to provide users with intelligent, digital and low-carbon overall solutions for pedestrian logistics.

**LINVOL** **WINONE**

## LINVOL

Leading brand of digital elevator

Pioneer in digital elevator industry; Based on the Internet of Things in elevators, with intelligent upgrades and full lifecycle management of elevators as the development direction, we comprehensively utilize new technologies such as CPU processing chips, big data analysis, artificial intelligence, and deep learning to effectively improve the level of elevator intelligence and make elevators more "intelligent, strong, and caring", bringing intelligent, digital, and low-carbon elevator experiences to passengers.

## WINONE

China's leading brand of freight elevators

National Invisible freight Elevator Champion; Top five Chinese national elevator brands; Focusing on user needs and experiences, we provide customers with professional, high-quality, and personalized elevator comprehensive solutions, equipment, and services.



**300+**

Cumulative special authorizations



**400+**

Professional R & D personnel



**278 items**

Participated in the revision of national inspection standards  
Post-Doctoral Research Center



**Provincial**

Guangdong provincial enterprise technology center



**CNAS**

has a certified Laboratory



# INTELLIGENT PRODUCTION

The LINVOL production line has been upgraded in an all-round way. Through intelligent manufacturing, lean production, process substitution, and flexible manufacturing upgrades, it has enabled the leap-forward development of digital elevators. With advanced technology to bring efficient production efficiency, the overall processing capacity is industry-leading.



### D&I operation

Order Flow Digitization  
Product line digitization  
Equipment Management  
EAM Digitization



### Auto-manufacturing

Sheet metal unmanned  
Host winding automation  
Flexible machining center  
automation



### Excellent service

Short delivery time, low  
cost products and  
services Innovative  
manufacturing  
technology leading



### Project breakthrough

AI visual inspection  
automatic welding  
equipment People-  
saving and labor  
-saving special machine  
robot project

## Innovative structural efficient design

Efficient flexible processing The self-adjustment of process and material parameters is highly consistent. More reliable quality control through the new four-folded structure

## Modular installation

Modular installation reduces welding structure, and the installation efficiency is increased by 10% compared with traditional products.

## Innovative technology

Imported production line - Salvagnini S4+P4 sheet metal flexible production line, with advanced sheet metal flexible processing system. With automatic, high efficiency, good flexibility, intelligence, informatization, easy Usability and other features and advantages.

## Efficient delivery

Innovative structural design, new digital production line, new process application, improve delivery efficiency. Provide customers with comfortable and secure elevator services, calmly respond to various needs, and improve customer satisfaction.

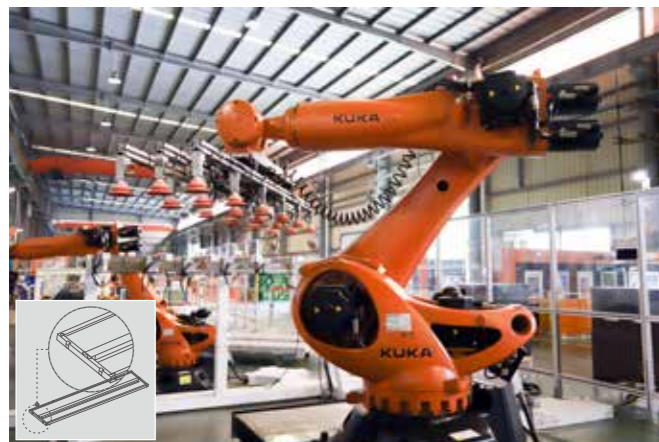

Production line plan



Salvagnini (automated production line)



Intelligent



Flexible



Efficient



### ORIGINALLY DEVELOPED TRACTION MACHINE



#### Ultra-thin host, thin design

Compact structure, the thickness of the whole machine is reduced by 75mm

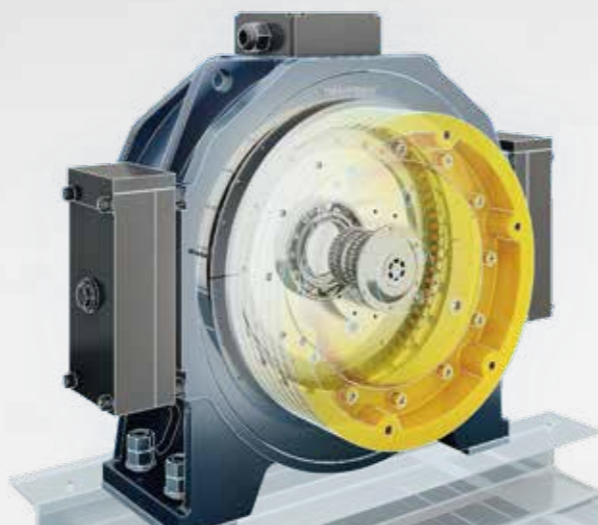

#### Secondary energy efficiency

Operating noise is less than 55db



#### Fully automatic winding stator technology

Shaft space utilization increased by 20%

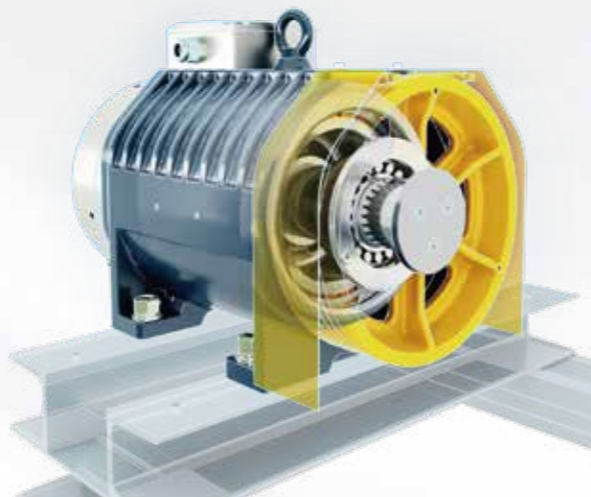

#### Fast and efficient processing

Special cantilever structure design, simple and quick to process and install



#### Safe and reliable

Combining the advantages of the inner rotor and the outer rotor, the structural safety factor is greater than 5 times



#### MR or MRL

Thin design, for MRL can be placed on rails

### ORIGINALLY DEVELOPED DOOR SYSTEM



#### Standardized and efficient

Single-person installation completed in 45 minutes

#### Well utilization rate is high

12% saving of hall door space  
11% saving of car door space

#### High performance/high standard/pre-maintenance

32-bit high-performance processor  
Pre-maintenance reminders for exceptions

#### Field installation has good fault tolerance

Double Floating Synchronized Door Skate Adjustable gate ball design

#### Intelligent security

Power-off anti-collision, door closing protection, etc. Real-time detection of working conditions and adaptive adjustment

#### Stable and reliable, strong sense of industry

Avoid secondary closures  
Anti-pinch protection



# MACHINE ROOM LESS ELEVATOR



## High shaft utilization rate

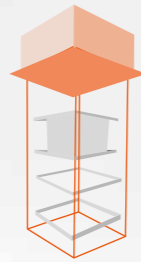

Compact structure design, suitable for various scenarios.  
The hoistway utilization rate is as high as 58.9% to maximize passenger load

## Super shallow pit

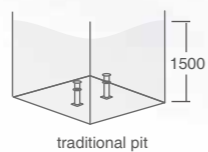

traditional pit

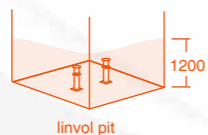

linvol pit

The bottom pit is as low as 1200, saving space and high installation efficiency. design

# MACHINE ROOM ELEVATOR

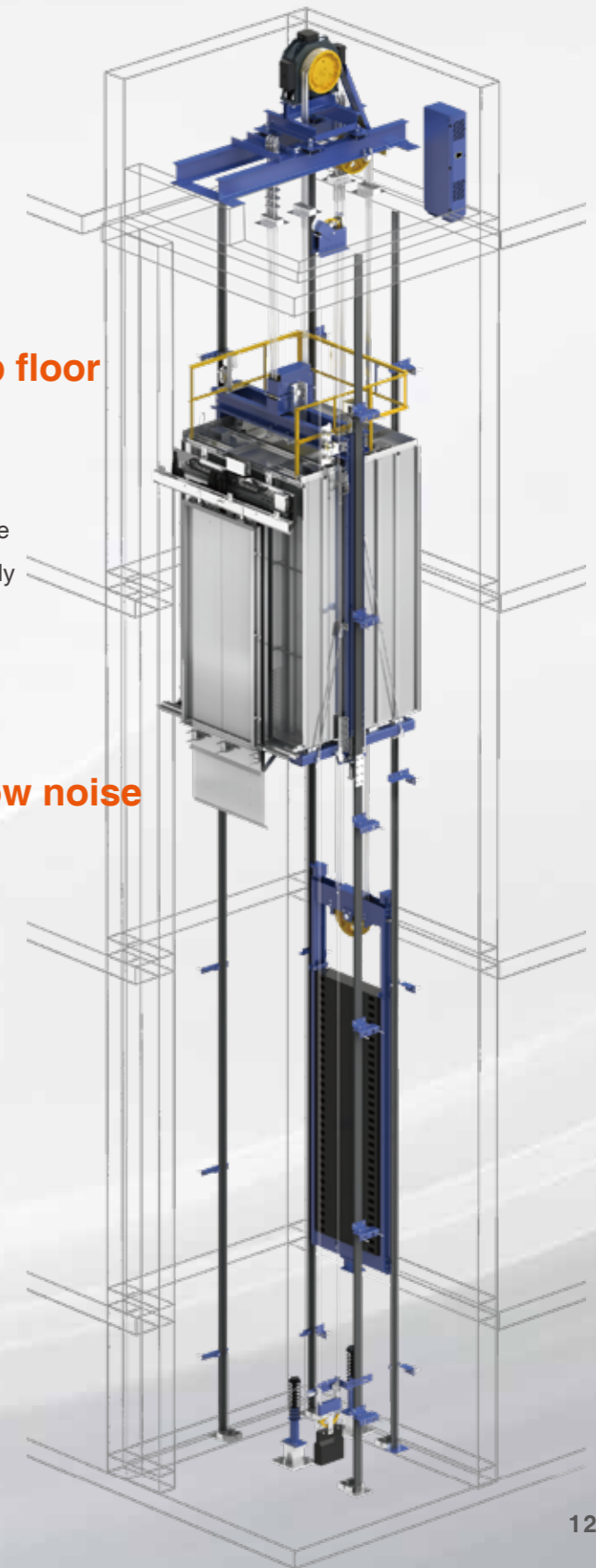

## Improve the utilization rate of the top floor

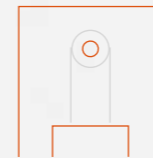

Machine room-less structure design, the compact strip traction The machine is flexibly placed in the shaft, effectively saving the building area and reducing the overall cost of the building.

## Stable and comfortable operation, low noise



We pursue the whole process of elevator operation to be guarded with peace of mind. Linvol's mature safety design and comfortable humanistic customs. Embracing and humanized functions make your riding experience comfortable. Ultra-quiet operation with just the right quality.



# PASSENGER LIFT

The application of digital intelligence technology not only changes the mechanical structure, but also makes customer no longer satisfied with the space enjoyment of "up and down". LINVOL Passenger Lift, based on the application of cutting-edge digital elevator technology, adopts new technical equipment and processing technology, and perfectly integrates the humanized design concept. It has excellent performance in operation performance, safety function, decoration design, energy saving and consumption reduction, and can be widely used in hotels, office buildings, residential / apartment buildings and other construction sites



**Intelligent building interconnection engine**  
Building full scene digital application



**MRL shaft design**  
The shaft utilization rate is as high as 58.9%



**Smart elevator management system**  
Realize trend prediction and abnormal warning



**Strengthen installation efficiency**  
Modular installation, efficiency increased by 10%



**Smart elevator service system**  
Improve personnel management efficiency



**Scene decoration design**  
Diversified decoration and complete supporting services





# STANDARD CONFIGURATION



COP018  
Embedded box  
white segment display



LOP028  
Slim type



B015W Button



F024-WMY  
White Mocha yellow  
PVC Floor



Hairline stainless steel

## CAR STANDARD DECORATION



### APY-01

Ceiling:  
C047 Powder coated pearl light grey RAL9022  
Cabin Wall:  
Powder coated steel panel, pearl light grey RAL9022  
Floor:  
F024-MG PVC floor



### AQY-01

Ceiling:  
C047A Hairline stainless steel + LED light  
Cabin Wall:  
Hairline stainless steel  
Floor:  
F024-WMY White Mocha yellow PVC Floor



Accessible lift  
Barrier-free design



**AQY-01BF**

Ceiling:  
C047 powder coated panel + LED light  
Cabin Wall:  
Hairline st. st. + mirror st. st. at middle panel of rear wall  
Floor:  
PVC floor



**AFA-01**

Ceiling:  
C077 powder coated panel + LED rectangle light  
Cabin Wall:  
Hairline st. st. + wooden pattern panel  
Floor:  
PVC floor



Panorama lift design  
Glass at rear wall



**AJY-02S**

Ceiling:  
C026 powder coated panel + LED light  
Cabin Wall:  
Hairline st. st. + rear wall glass  
Floor:  
PVC floor



**AGY-01**

Ceiling:  
Powder coated + wooden pattern panel + LED rectangle light  
Cabin Wall:  
Powder coated panel + wooden pattern panel  
Floor:  
PVC floor





**AJY-01**

Ceiling:  
M001 Baking paint metallic grey Etching P001 + painted steel board + LED light  
Cabin Wall:  
Hairline stainless steel  
Painted steel board + etching 001  
Floor:  
F016 PVC Floor



**AQY-01S**

Ceiling:  
Suspended ceiling platinum color hairline st. st.+ hidden LED strip lights around  
Cabin Wall:  
Platinum color hairline st. st. + platinum color mirror st. st.  
Floor:  
PVC floor

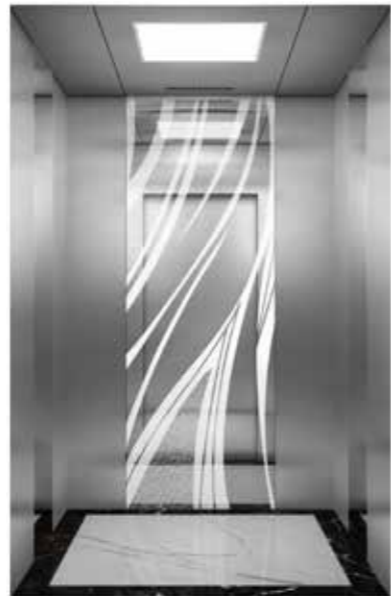

**AQY-01A**

Ceiling:  
C047 powder coated panel + LED light  
Cabin Wall:  
Hairline st. st. + etched mirror st. st. at middle panel of rear wall  
Floor:  
PVC floor

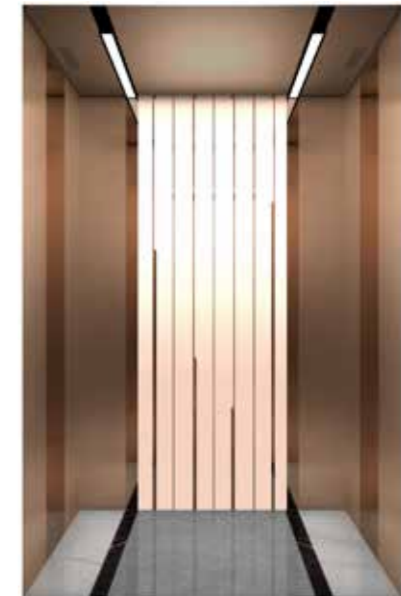

**AGY-01B**

Ceiling:  
Rose gold color hairline st. st. + LED rectangle light  
Cabin Wall:  
Rose gold color hairline + mirror + etched mirror st. st.  
Floor:  
PVC floor



Medium design  
Residential building



**ACY-01**

Ceiling:  
Suspended ceiling soft film LED light +  
black mirror st. st. frame  
Cabin Wall:  
Titanium gold color hairline + etched mirror st. st.  
Floor:  
PVC floor



Medium design  
Hotel



**AHY-01**

Ceiling:  
Powder coated gold color panel + LED light  
Cabin Wall:  
Titanium gold color hairline + mirror + etched mirror st. st.  
Floor:  
PVC floor



**AJY-01S**

Ceiling:  
Suspended ceiling soft film LED light +  
black mirror st. st. frame  
Cabin Wall:  
Black hairline st. st. + mirror st. st. + etched st. st.  
Floor:  
PVC floor



**ABY-01**

Ceiling:  
C071 mirror copper golden st. st. +  
golden color powder coated  
Cabin Wall:  
Hairline copper golden st. st. + mirror + etched P061  
Floor:  
F055 PVC floor



Luxury design  
Hotel



**ALX-01**

Ceiling:  
C050 M002 baking varnish elegant gold Apple sand  
titanium gold trim strip LED lighting in the middle,  
hidden atmosphere lights around  
Cabin Wall:  
Apple sand bronze gold + anti fingerprint P011 retro craft +  
anti fingerprint  
Floor:  
F020, Bulgarian grey marble



Luxury design  
Hotel



**AWJ-01**

Ceiling:  
M002 baking varnish elegant gold  
Transparent acrylic hidden LED light band around  
Cabin Wall:  
Apple sand bronze gold + anti fingerprint  
P008 decorative film steel plate  
Floor:  
F020, Magnolia marble



Luxury design  
Residential building

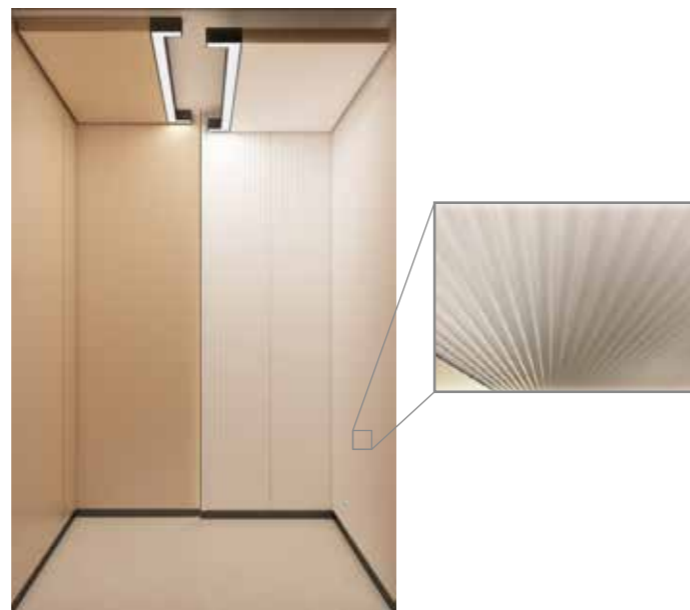

**ADY-01**

Ceiling:  
C051 Apple sand bronze gold Matte white  
sprayed steel plate Middle LED lighting  
Cabin Wall:  
Apple sand bronze gold + anti fingerprint Art decorative board  
Floor:  
F020, Bulgarian grey marble



Luxury design  
Office

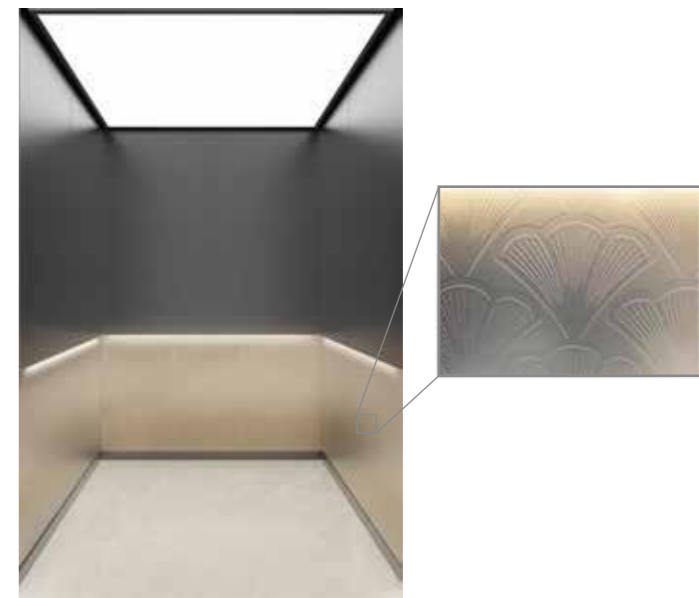

**AZX-01**

Ceiling:  
C045 Soft film ceiling Apple sand black border  
Cabin Wall:  
Titanium black st. st. at top baking varnish gold flower  
at bottom with atmosphere light  
Floor:  
F020, Grey marble



OPTIONAL COP



6.4SEG  
White segment display

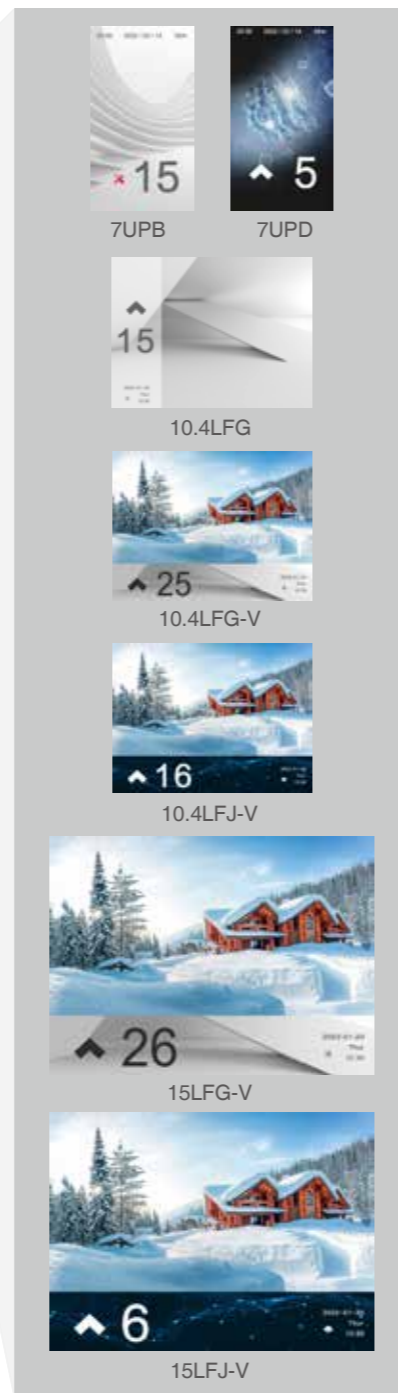

Note: Display vertical arrangement as default,  
if need horizontal please inform factory

Standard COP



**COP014**

Integrated panel at front wall  
white segment display

**COP007**

Integrated panel at front wall  
LCD display

**COP018**

Embedded box at front/side  
white segment display

**COP015**

Embedded box with  
tempered glass panel

**COP017**

Accessible type

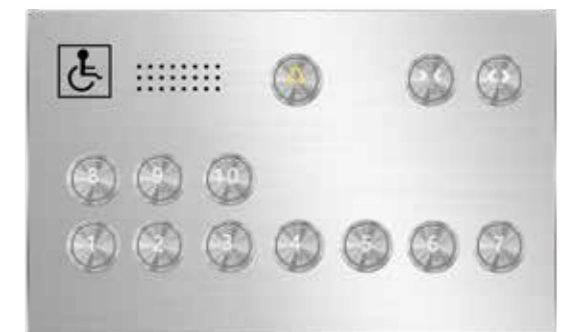



### SLIM TYPE LOP

Standard LOP



**LOP028**  
Slim type, 4.3"  
white segment display



**LOP008**  
Slim type, 4.3"  
white segment display

### BOX TYPE LOP (OPTIONAL LOP)

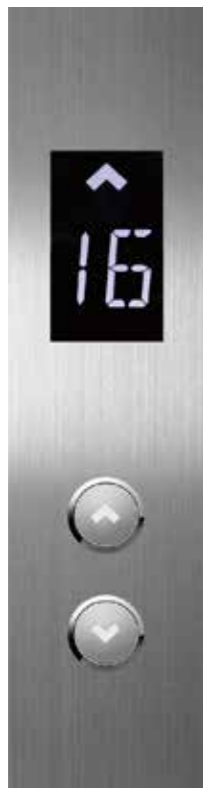

**LOP009**  
Box type  
hairline st. st.



Horizontal indicator  
4.3" LCD display



**LOP012**  
Box type  
button only



**LOP010**  
Box type  
tempering glass

### OPTIONAL BUTTONS



**B002W**



**B003W**



**B004W**



**B005W**



**B006W**



**B007W**  
Label text DIY button



**B009W**  
Big button

### HALL LANTERN



**HL001**



**HL002**



**HL003**

### FACE RECOGNITION



ONE TIME  
FACE REGISTRATION

With one time face registration, passenger can call elevator and put floor number without pressing the button/number or enter identification card.



TOUCHLESS

Touchless method:  
More safety - more convenient - more security.



FACE-MASK  
DETECTION SYSTEM

With smart face-mask detection system, passenger can be detected exactly even wearing the mask.





FLOOR DECORATION

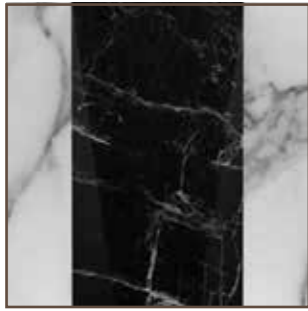

F016



F020-OLG



F021



F023

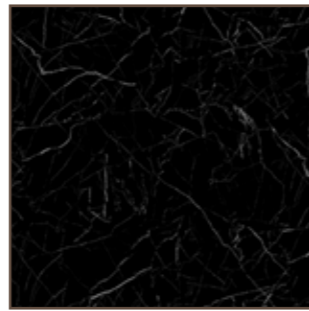

F024-PB



F024-MG



F037



F054



F055

HANDRAIL



H001



H002



H003



H004



H004A



H005



H006



H007

OPTIONAL LANDING DOOR



P038

Landing Door:  
Sandblasting black + etching  
P038  
Door jamb: Sandblasted  
stainless steel



P034

Landing Door: Mirror  
platinum + etching P034  
Door jamb: Apple sand  
platinum gold



P036

Landing Door: Apple sand  
bronze gold + etching P036  
Door jamb: Apple sand  
bronze gold



P037

Landing Door: Mirror  
sandblasting P037  
Door jamb: Sandblasted  
stainless steel



P035

Landing Door: Apple sand  
bronze gold + etching P035  
Door jamb : Apple sand  
bronze gold



# ELECTRICAL FUNCTION LIST

Safety Protection Functions				Standard ● Option ○
No.	abbreviation	function	description	Standard/Option
1	SAFO	safety operation	The elevator can run only under safe conditions. The elevator that meets the conditions can start running, otherwise the elevator cannot start, and the running elevator stops immediately	●
2	MCCD	contact detection protection of main contactor	The system checks up whether any inconformity between main contactor drive output and contact detection, the elevator would activate fault protection.	●
3	BCCD	contact detection protection of brake contactor	The system checks up whether any inconformity between brake contactor drive output and contact detection, the elevator would activate fault protection.	●
4	SCCD	contact detection protection of sealing star contactor	1)After the main contactor is disconnected, the star sealing contactor is delayed to disconnect 2)The system checks up whether any inconformity between sealing star contactor drive output and contact detection, the elevator would activate fault protection.	●
5	BCD	contact detection protection of brake switch contactor	The system check the reliability of band-type brake through its switch. Protection will be launched once the band-type brake is found not reliable.	●
6	OSP	Over speed protection	Elevator would stop due to running speed higher than control limit.	●
7	LSP	Low speed protection	Elevator would stop due to running speed lower than control limit.	●
8	WDP	Wrong direction protection	When the system has detected an inconsistency between the elevator registered direction and travel direction for a while, an emergency stop will be activated with the alarm buzzing on.	●
9	OL	Overload protection	If loading in car cage is bigger than 110% rated load, the door remains open with alarm buzzing on and visible warning notice.	●
10	SLFP	Safety circuit protection	Elevator would stop once safety circuit disconnect while elevator running.	●
11	DLFP	Door lock circuit protection	Elevator would stop once door lock circuit disconnect while elevator running.	●
12	MSP	Motor skidding protection	If the elevator in operation has traveled incessantly for a longer time than the value preset by the time limiter, the system will activate the skidding protection	●
13	MOP	Motor overheat protection	This protection function is setted to prevent the traction motor from overheating and causing dangerous operation. If the traction motor starts to overheat, the elevator car is driven to the nearest possible floor wherethe doors will open to let passengers out of the car . After the motor coolsdown the elevator will resume normal operation.	●
14	LSFP	Leveling switch fault protection	A protection functions to be activated in case of abnormal situations casued by failure of leveling switch.	●
15	UCMP	Unintended car movement protection	It can prevent passengers from being injured by unintended car movement when entering and exiting the car	●
16	SSD	Sealing star delay circuit protection	Short-circuit the three windings of the synchronous traction machine to prevent the elevator from being too fast and out of control when the brake is released	●
17	LWP	Limit switch protection	Limit switch installed at the top, bottom of the shaft will protect the elevator run over-travels.	●
18	DAP	Deceleration switch failure protection	When encountering the deceleration switch failure, elevator land in emergency to avoid possible top or bottom floor collision.	●
19	SLP	Leveling position failure protection	The elevator would activate fault protection when the automatically stopping floor is inconsistent with displaying floor	●
20	DOFP	Door opening fault protection	The elevator would activate fault protection when door cannot be opened after the specified number of consecutive times.	●
21	DCFP	Door closing fault protection	The elevator would open the door and activate fault protection in case door cannot be closed after the specified number of consecutive times, or the door lock cannot be closed after the door close.	●
22	DLSCD	Door lock short circuit detection	In automatic state, whether every landing door lock and car door lock are shorted would be detected after the elevator arrive at leveling area and opens the door.	●
23	DOCPD	Open & close door achieving detection	The elevator would activate fault protection in case door open achieving signal and door close achieving signal activate at the same time.	●
24	LCP	Light curtain protection	In automatic state, the light curtain detects if there are passengers or other objects between the doors and so prevents the doors from closing	●
25	BFDP	Brake Torque Detection Function	1)When the braking torque is slightly insufficient after detection, the elevator can operate normally. Record the fault and prompt to report it, and repair it as soon as possible. 2)When the braking torque is seriously insufficient after detection, the elevator door closes and activate fault protection, which needs to be repaired immediately	●
26	WDTP	Master CPU protection by WDT	The master control PCB is integrated with WDT protection. When any CPU or program problems are detected, the WDT circuit will make a forced cutoff at the output terminals of the master control and reset the CPU	●

Trip Operating Functions				Standard ● Option ○
No.	abbreviation	function	description	Standard/Option
1	FCC	Fully collective control	When in automatic or attendant control, the elevator stops in response to the in-car registrations while automatically follows landing calls up and down, i.e., a passenger can register his or her call at any landing.	●
2	FLNS	Full load non-stop	When a full loaded elevator can travels in automatic mode without attendant, the elevator will not answer any calls from its passing landings, stopping at the landings by in-car registrations only.	●
3	AS	Attendant service	Using the switch in the car operation panel, one can put the elevator into attendant service, under which the automatic door closing is absent and the door can only be closed when attendant keep pressing the door-closing button. Meanwhile the function can also allow attendant to choose direction and by-passing.	●
4	INDO	Independent trip	Independent trip is VIP trip function, during which the elevator overlooks all landing calls and automatic door-closing is absent. Other features are similar to attendant service.	●
5	FS	Fire emergency return	When the elevator receives the fire signal, the elevator will immediately clear out all instruction and call and then return to firefighting base floor, the elevator stop service with the door opening.	●
6	MLR	Main landing return	When the elevator travels in automatic mode without attendant service while setting this function in effect, the elevator which receives neither in-car nor landing calls will automatically return to the main landing within a given period of time determined by parameter setting.	●
7	PKS	Parking switch	Setting the parking switches of elevator in automatic mode or with attendant, and clear up all the registration call. The elevator only respond to the in-car instruction until no new instructions registered. Then the elevator returns to the base station, turns off in-car lighting and automatically close the door when 10 seconds time delay expired. Finally, the elevator stops running, and will be back to operation when the parking switch reset.	●
8	SAS	Leveling on changing destination landing	If the door has been opening longer than the setting time without activating the door open limit switch, the door will close and the elevator will travel to the next floor after the door is closed.	●
9	ESO	Car light auto turn off	Automatically turn off the car light & fan when the elevator is idle, saving energy.	●

Controlling Functions				Standard ● Option ○
No.	abbreviation	function	description	Standard/Option
1	DIRD	Direct landing	The elevator can run only under safe conditions. The elevator that meets the conditions can start running, otherwise the elevator cannot start, and the running elevator stops immediately	●
2	LSSR	Self-rescue	When the elevator stays out of the leveling zone (not in inspection state), it will automatically move to the leveling zone slowly to evacuate the passengers only if meeting safety requirements of starting.	●
3	SLCF	Start-up loading weighting compensation	To improve passengers' comfort feeling while the elevator start up, the load compensation value is given based on the car load data inspected by the weighing device.	●
4	ACFP	Automatic correction in landing position signals	The travelling elevator system compare its own position signals at each terminal switch and the leveling switch of each landing against those obtained by self-study and making automatic data corrections accordingly.	●
5	FRDS	Front/rear door setting service	Passenger can make independent control of the front and rear door according to their own needs.	●
6	TDFE	Service floor by time setting	The specified floor would be setting to serve within a specified time, and other floors will not serve	●
7	PELS	Parking by time setting	Set the elevator parking at a specific time	●
8	TIMACS	Arrival gong by time setting	Set the start and end time, and enable the arrival gong function within the time period, which is mainly used to cancel the arrival gong ringing at night	●

Inspection & Comissioning Functions				Standard ● Option ○
No.	abbreviation	function	description	Standard/Option
1	INSO	Inspection operation	When operation conditions are satisfied, an authorized person can inch the car by pressing and releasing the red button, he can move the car at inspection speed by continuously pushing down the button and stop it by releasing the button.	●
2	TESR	Testing operation	It is a function designed for measuring the performance of a new elevator. By setting a given parameter in testing travel on the master control board, a field engineer will put the elevator into automatic operation. Both the total number of trips and the interval time between trips of the testing travel can be determined by parameter setting.	●
3	FAUR	Fault history log	Keeps 20 fault records concerning the occurrence time, floors and fault codes.	●
4	LUA	Leveling overall-tuning	Adjust the leveling position of the floor in a tiny range at one time by debugging the equipment (when the upward or downward deviation for each floor is the same)	●
5	LFT	Leveling fin-tuning	Use the software to adjust the leveling switch position of each floor within a tiny range. So the complicated procedure of adjusting leveling plug-in board can be avoided.	●
6	OPEC	Operation counter	Operation counter (trip and hour, mean time between failure)	●
7	EIE	Evaluation on encoder interference	Use operator to check the interference of encoder signal	●
8	CIA	Evaluation on communication interference	Use operator to check the communication quality	●
9	HCBQ	External board search function	Use operator to check whether the external board at each floor work properly or not	●
10	EMBC	Evaluation and monitoring of balance coefficient	By setting the rated load and test parameter values, the empty load test and full load test are performed respectively, and the balance coefficient is displayed after the elevator automatically runs from the bottom floor to the top floor	●

Door Operating Functions				Standard ● Option ○
No.	abbreviation	function	description	Standard/Option
1	AUTD	Automatic door	When in automatic mode, the elevator door would be opened automatically as it arrive at assigned landing.	●
2	DOPS	Door opening setting	Whether the front and rear doors of each floor are allowed to open can be set as required	●
3	DOB	Door open button	When the car stays within the door zone, a passenger in the car can open a closed door or make a closing door reverse by pushing on the door-opening button.	●
4	DOTS	Waiting after door open	When the elevator travels in automatic state without attendant, the door closes automatically by a delay after the car arrives at a landing with the door open.	●
5	RDPB	Reopen door after push landing button	When the call button of this landing is pressed down, the car door opens automatically. If someone keeps pushing on the button, the door remains open.	●
6	DCB	Door close button	When the door is open in automatic state, the door can be closed immediately before the delay elapses by pushing the door-closing button.	●
7	DN	Door nudging	If the elevator keep door opening and no door-closing signal are sent due to light curtain or other reason, the elevator will be forced to close.	●
8	RDCF	Re-close door	In order to prevent door-closing failure from the contingent failure of the door machine system and possible door block by something, this function is therefore provided to re-close the door.	●
9	ODWL	Door opening standby function	Use parameter setting to choose the elevator door-opening and standby for main floor or other floors	●
10	DAVF	Door lock anti vibration	After the elevator door is closed in place, it will be delayed for a period of time to cancel the door closing output after the door lock is closed stably	●
11	DTH	Door torque holding	Set whether to continuously output the opening / closing command after the door is opened in place / closed in place according to the demand	●
12	DLBF	Door Lock Bypass Function	The function can prevent the abuse of the short-circuit wire of the door lock and forget to remove it after use	●
13	DDOO	Disable door open	When the elevator responds to instructions or door opening signals from the handicapped COP, the door opening hold time is extended	●



# ELECTRICAL FUNCTION LIST

## Command Management Functions Standard ● Option ○

No.	abbreviation	function	description	Standard/Option
1	WCC	Wrong call cancel	If a passenger realizes that he or she has pushed down a wrong button in the car panel, he or she can cancel the wrong registration by pushing the same button twice incessantly. The registered signal will be canceled.	●
2	REVC	Clear registrations at changing direction	When the elevator car arrives at the last landing and is about to reverse the direction, all the registrations behind its present travel will be cancelled at once.	●
3	SLS	Service landing setting	The function can setting at which floors the elevator serves and which floors the elevator does not serve.	●
4	BAD	Relieve button adhesion	The system automatically recognizes the button adhesion, and the signal of the button will not be accepted after the adhesion fault occurs; Until the button contact with adhesion failure is disconnected, the system will accept the button signal again, and the button will return to normal use	●

## Voice Soothing Function Standard ● Option ○

No.	abbreviation	function	description	Standard/Option
1	SSVC	Voice Soothing Function	After the elevator breaks down, the passengers will be informed of the soothing voice information	●

## Optional Function Standard ● Option ○

No.	abbreviation	function	description	Standard/Option
1	ARED	Automatic rescue device	When the car has stopped between floors and passengers are trapped because of a failure of power supply , the car emergency operation will be activated, and the door will be opened to release people at the nearest landing.	○
2	EQO	Earthquake function	Upon operation of a seismic detector, every elevator in the group should immediately stop and make a correction drive down at the nearest possible floor.	○
3	ADO	Door open in advance	The option enable leveling elevator to open door immediately upon arrival at the pre door-opening zone. In this way the elevator operation is more efficient.	○
4	IDC	Independent control function of front and rear doors	1) the independent control of front and rear doors of the rear door control box; 2) the independent control of front and rear doors when there is a rear landing opening panel	○
5	CCM	Car arrival gong	The Up/Down arrival gong in car will ring as the elevator decelerate and level, alarming the passengers that the elevator is leveling and about to arrival.	○
6	MIT	Peak Service Function (Upward)	In automatic state or attendant service state, when the elevator is running, it only responds to the upward button at all landing meanwhile responding to the command signal in the car	○
7	MOT	Peak Service Function (Downward)	In automatic state or attendant service state, when the elevator is running, it only responds to the downward button at all landing meanwhile responding to the command signal in the car	○
8	SSMF	Voice announcement (arrival)	The broadcaster will report the upcoming floor during the leveling process and report the running direction of the elevator at each time of door-closing. (The voice resource is input by customer)	○
9	SSMX	Voice announcement (door opening)	The broadcaster will report door opening tips at each time of door-opening. (The voice resource is input by customer)	○
10	SSMBGDM	Voice announcement (background music)	The broadcaster will broadcast background music when the elevator is running.	○
11	AGVLF	AGV linkage function	Link with intelligent robot AGV(Automated Guided Vehicle), AGV can automatically use the elevator to other floors	○
12	CARFR	Face recognition function (in car)	Face recognition equipment is used in the car to control the authority of elevator passengers. Recognizing is correct, the floor of passengers is automatically registered. Passengers' hands are safer no need to touch the panel.	○
13	HALLFR	Face recognition function (landing)	Face recognition equipment is used at landing to control the authority of elevator passengers. Recognizing is correct, automatically register the up/down direction command according to the floor of passenger. Passengers' hands are safer no need to touch the panel.	○
14	ELEIOT	IOT function	Using Internet of things technology to establish a big data platform processing system for elevator remote detection, electronic operation and maintenance, full life cycle fault analysis and health intelligent prediction, and send the collected elevator alarms, events, faults and other signals as well as comprehensive operation and status data to the remote application platform in time. Through the data analysis and processing of the platform, the intelligent management of the elevator is realized	○
15	CARC	Video monitoring	Through the camera equipment, real-time monitoring of the status of passengers and the environment in car cage.	○
16	SFFS	Second refuge floor	If detect fire at main fire refuge floor, elevator returning to the 2nd fire refuge floor, opening the door to release passengers	○
17	FIRS	Fireman service	When the fireman's switch is set on, the elevator will immediately clear out all instruction and call and then return to main fire refuge floor, the elevator stop service with the door opening. The fireman operates the door open/close and floor registration, after the elevator returns to the main fire refuge floor and resets the fireman's switch, then the elevator can switch to normal operation.	○
18	SECL	Security floor setting	The security floor function make the security floor is effective during customer setting period. Every time the elevator passes the security floor, it will stop and then run to next destination floor.	○
19	ANTI	Anti-nuisance	When the elevator in light load, the in-car registrations have reached or exceeded the setting value(5). The system will clear all the registration.	○
20	VISF	Visitor services	When there are customers visiting, the restricted floor is open for visitors	○
21	SDF	Earthquake function	Upon operation of a seismic detector, every elevator in the group should immediately stop and make a correction drive down at the nearest possible floor.	○
22	RELE	Re-leveling	When the system detects that the leveling is inaccurate, re-leveling will start with the car running at a low speed (recommend be selected with high-rise lifts)	○
23	OTCALL	One-touch calling	Audio gateway is connected to the elevator's intercom. Through a voice call SIM card (by user), the car emergency button is triggered in case of an emergency, and the emergency contact number is actively dialed to achieve voice dialing for rescue calls.	○
24	BAS	BA Interface	The elevator control cabinet reserves BA interface, which outputs elevator information such as up, down, current floor, fault status, lock status, etc. through the 485 interface and MODBUS-RTU communication protocol.	○
25	ENRTFF	Energe regenerative	Feed back the energy generated by the elevator during the braking process to the power grid.	○
26	EDOHT	Door hold button	Push the door hold button on COP, extend door opening hold time,very useful for freight lift or bed lift.	○
27	VOLRF	Voltage stabilizer	Stabilize the fluctuation value of the power supply within the range that allows the elevator to operate normally.	○
28	DCAF	Door close warning	Within the time set before closing the door, an audible and visual warning will be output to remind users to pay attention to the closing and prevent passengers or goods from hitting the landing door during closing.	○
29	ULDL	Disinfection sterilization	Use UV disinfection light to disinfect the cabin when it is empty and unoccupied.	○
30	ACCBY	Disable lift package	For disable people usage, including voice announcement, handicapped COP, handrail in car, rear wall mirror.	○





# PLANNING DATA

## PASSENGER LIFT / MACHINE ROOM LESS

### MLVEL-RML EVIN

	CAPACITY (kg)	PERSONS	SPEED (m/s)	CAR SIZE (CWxCDxCH)	DOOR SIZE (DWxDH)	SHAFT SIZE (SWxSD)	OVERHEAD (OH)	PIT DEPTH (PD)
CWS (Counterweight at Side)	630	8	1.0	1100x1400x2300 <sup>4)</sup>	C2 <sup>1)</sup> 800x2100	1850x1850	4000/3850 <sup>2)</sup>	1200
			1.5				4300/4100 <sup>2)</sup>	1400
			1.75				4350/4150 <sup>2)</sup>	1450
	800	10	1.0	1350x1400x2300	C2 800x2100	2100x1850	4000/3850 <sup>2)</sup>	1200
			1.5				4300/4100 <sup>2)</sup>	1400
			1.75				4350/4150 <sup>2)</sup>	1450
			2.0				4450/4350 <sup>2)</sup>	1500
			2.5				4650/4600 <sup>2)</sup>	1700
			2.5				4000/3850 <sup>2)</sup>	1200
	1000	13	1.5	1600x1400x2300	C2 900x2100	2350x1850	4350	1400
			1.75				4450	1450
			2.0				4600	1500
			2.5				4700	1700
	1050	14	1.0	1600x1500x2300	C2 900x2100	2350x1950	4000/3900 <sup>2)</sup>	1200
			1.5				4450	1400
			1.75				4550	1450
			2.0				4600	1500
			2.5				4700	1700
	1050 (STRECHER)	14	1.0	1100x2100x2300	S2 <sup>1)</sup> 900x2100	1850x2600	4000/3900 <sup>2)</sup>	1200
			1.5				4450	1400
			1.75				4550	1450
			2.0				4600	1500
	1150	15	1.0	1800x1400x2400	C2 1100x2100	2600x1850	4100	1250
			1.5				4450	1450
1.75			4550				1450	
2.0			4700				1550	
2.5			4800				1750	
1250	16	1.0	2000x1400x2400	C2 1100x2100	2800x1850	4100	1250	
		1.5				4650	1450	
		1.75				4700	1450	
		2.0				4750	1550	
1350	18	1.0	2000x1500x2400	C2 1100x2100	2800x1950	4100	1250	
		1.5				4650	1450	
		1.75				4700	1450	
		2.0				4750	1550	
		2.5				4800	1750	
1600	21	1.0	2000x1700x2400	C2 1100x2100	2800x2150	4100	1250	
		1.5				4650	1450	
		1.75				4700	1450	
		2.0				4750	1550	
1600 (STRECHER)	21	1.0	1400x2400x2400	S2 <sup>1)</sup> 1100x2100	2200x2900	4100	1250	
		1.5				4650	1450	
		1.75				4700	1450	
		2.0				4750	1550	
		2.5				4800	1750	

- Note:
- C2 is 2 panel central opening door, S2 is 2 panel side opening door.
  - The 1st value is for EN81-20, the 2nd value is for EN81-1, only one value is available for both EN81-20 and EN81-1.
  - In case false ceiling, the overhead shall increase 150mm.
  - Available car height: 2100-3500mm.
  - Please consult the factory when there is accessible space under the pit(with cwt safety gear).

SPEED (m/s)	RISE MAX. (m)
1.0	50
1.5	75
1.75	90

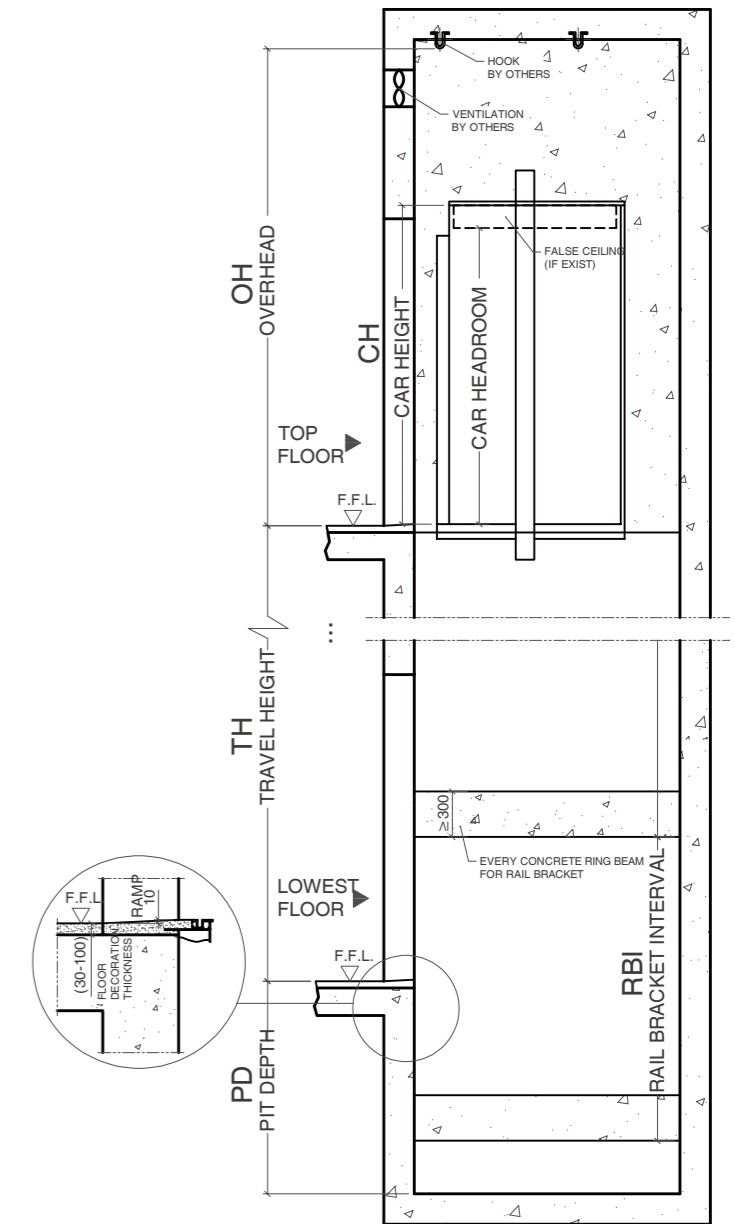
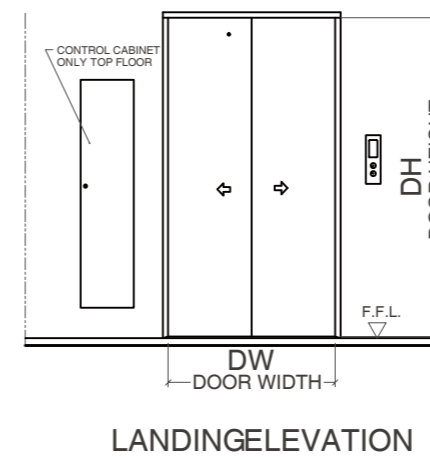
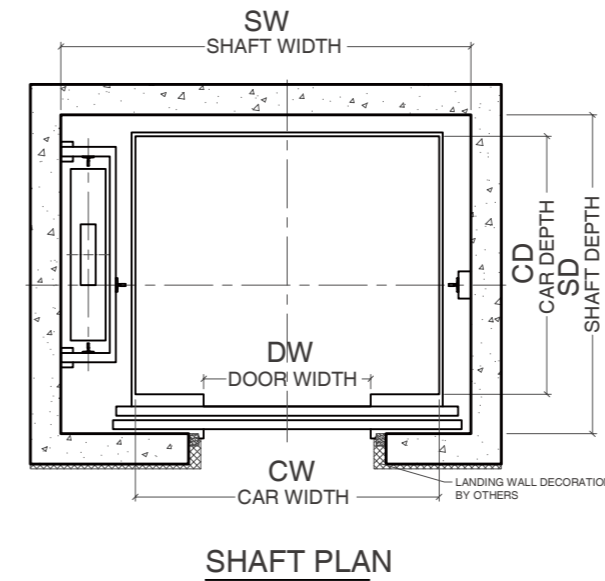

NOTE: PLEASE REFER TO THE PROJECT GAD FOR MORE DETAILS.



# PLANNING DATA

## PASSENGER LIFT / MACHINE ROOM

### MLVEL-RMR EVIK

	CAPACITY (kg)	PERSONS	SPEED (m/s)	CAR SIZE (CWxCDxCH)	DOOR SIZE (DWxDH)	SHAFT SIZE (SWxSD)	OVERHEAD (OH)	PIT DEPTH (PD)
CWR (Counterweight at Rear)	630	8	1.0	1400x1100x2300 <sup>4)</sup>	C2 <sup>1)</sup> 800x2100	1900x1800	4600/3650 <sup>2)</sup>	1500/1200 <sup>2)</sup>
			1.5				4900/3900 <sup>2)</sup>	1700/1400 <sup>2)</sup>
			1.75				4950/4000 <sup>2)</sup>	1750/1450 <sup>2)</sup>
	800	10	2.0	1400x1350x2300	C2 800x2100	1900x2000	5050/4050 <sup>2)</sup>	1800/1500 <sup>2)</sup>
			1.0				4000/3650 <sup>2)</sup>	1500/1200 <sup>2)</sup>
			1.5				4300/3900 <sup>2)</sup>	1700/1400 <sup>2)</sup>
	1000	13	1.75	1600x1400x2300	C2 900x2100	2100x2050	4350/4000 <sup>2)</sup>	1750/1450 <sup>2)</sup>
			2.0				4450/4050 <sup>2)</sup>	1800/1500 <sup>2)</sup>
			2.5				4650/4300 <sup>2)</sup>	1950/1700 <sup>2)</sup>
	1050	14	1.0	1600x1500x2300	C2 900x2100	2100x2150	4000/3650 <sup>2)</sup>	1500/1200 <sup>2)</sup>
			1.5				4300/3900 <sup>2)</sup>	1700/1400 <sup>2)</sup>
			1.75				4350/4000 <sup>2)</sup>	1750/1450 <sup>2)</sup>
	1150	15	2.0	1800x1400x2400	C2 1000x2100	2300x2150	4450/4100 <sup>2)</sup>	1800/1500 <sup>2)</sup>
			2.5				4650/4500 <sup>2)</sup>	1950/1700 <sup>2)</sup>
			1.0				4200/4000 <sup>2)</sup>	1250
	1250	16	1.5	2000x1400x2400	C2 1100x2100	2500x2150	4450/4250 <sup>2)</sup>	1450
			1.75				4500/4300 <sup>2)</sup>	1450
			2.0				4600/4400 <sup>2)</sup>	1550
1350	18	2.5	2000x1500x2400	C2 1100x2100	2500x2250	4800/4700 <sup>2)</sup>	1750	
		1.0				4200/4000 <sup>2)</sup>	1250	
		1.5				4450/4250 <sup>2)</sup>	1450	
1600	21	1.75	2000x1700x2400	C2 1100x2100	2500x2450	4500/4300 <sup>2)</sup>	1450	
		2.0				4600/4400 <sup>2)</sup>	1550	
		2.5				4800/4700 <sup>2)</sup>	1750	
CWS (Counterweight at Side)	630	8	1.0	1100x1400x2300	C2 800x2100	1850x1850	4200/4000 <sup>2)</sup>	1250
			1.5				4450/4250 <sup>2)</sup>	1450
			1.75				4500/4300 <sup>2)</sup>	1450
	800	10	2.0	1350x1400x2300	C2 800x2100	2000x1850	4450/4050 <sup>2)</sup>	1500
			2.5				4650/4250 <sup>2)</sup>	1700
			1.0				4000/3600 <sup>2)</sup>	1200
	1000	13	1.5	1600x1400x2300	C2 900x2100	2250x1850	4300/3900 <sup>2)</sup>	1400
			1.75				4350/3950 <sup>2)</sup>	1450
			2.0				4450/4100 <sup>2)</sup>	1500
	1050 (STRECHER)	14	2.5	1100x2100x2300	S2 <sup>1)</sup> 900x2100	1800x2600	4650/4500 <sup>2)</sup>	1700
			1.0				4000/3600 <sup>2)</sup>	1200
			1.5				4300/3900 <sup>2)</sup>	1400
	1150	15	1.75	1800x1400x2400	C2 1100x2100	2550x1850	4350/3950 <sup>2)</sup>	1450
			2.0				4450/4100 <sup>2)</sup>	1500
			2.5				4650/4500 <sup>2)</sup>	1700
	1250	16	1.0	2000x1400x2400	C2 1100x2100	2750x1850	4000/3600 <sup>2)</sup>	1200
			1.5				4300/3900 <sup>2)</sup>	1400
			1.75				4350/3950 <sup>2)</sup>	1450
1350	18	2.0	2000x1500x2400	C2 1100x2100	2750x1950	4450/4200 <sup>2)</sup>	1500	
		2.5				4650/4600 <sup>2)</sup>	1700	
		1.0				4100/3800 <sup>2)</sup>	1250	
1600 (STRECHER)	21	1.5	1400x2400x2400	S2 1100x2100	2200x2900	4400/4050 <sup>2)</sup>	1450	
		1.75				4450/4150 <sup>2)</sup>	1450	
		2.0				4550/4250 <sup>2)</sup>	1550	
			2.5				4750/4600 <sup>2)</sup>	1750

Note:

- C2 is 2 panel central opening door, S2 is 2 panel side opening door.
- The 1st value is for EN81-20, the 2nd value is for EN81-1, only one value is available for both EN81-20 and EN81-1.
- In case false ceiling, the overhead shall increase 150mm.
- Available car height: 2100-3500mm.
- Please consult the factory when there is accessible space under the pit(with cwt safety gear).

SPEED (m/s)	RISE MAX. (m)
1.0	50
1.5	75
1.75	90
2.0	110
2.5	125

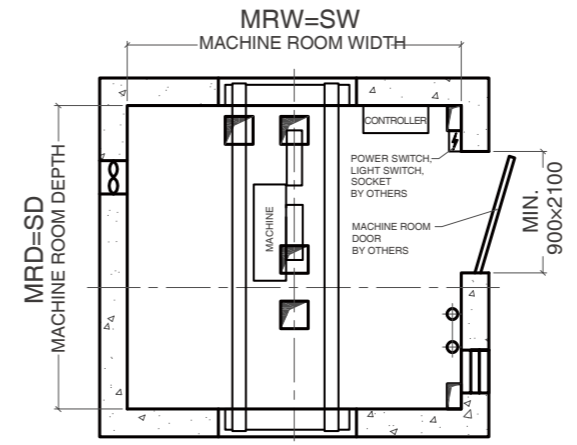

MACHINE ROOM PLAN

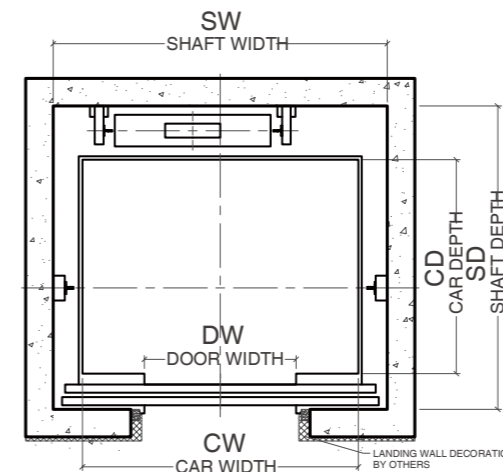

SHAFT PLAN

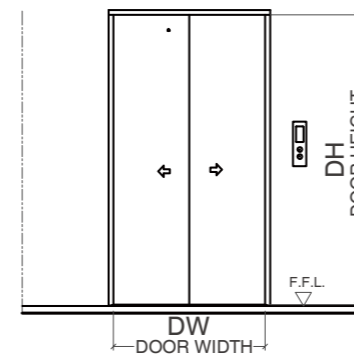

LANDING ELEVATION

NOTE: PLEASE REFER TO THE PROJECT GAD FOR MORE DETAILS.

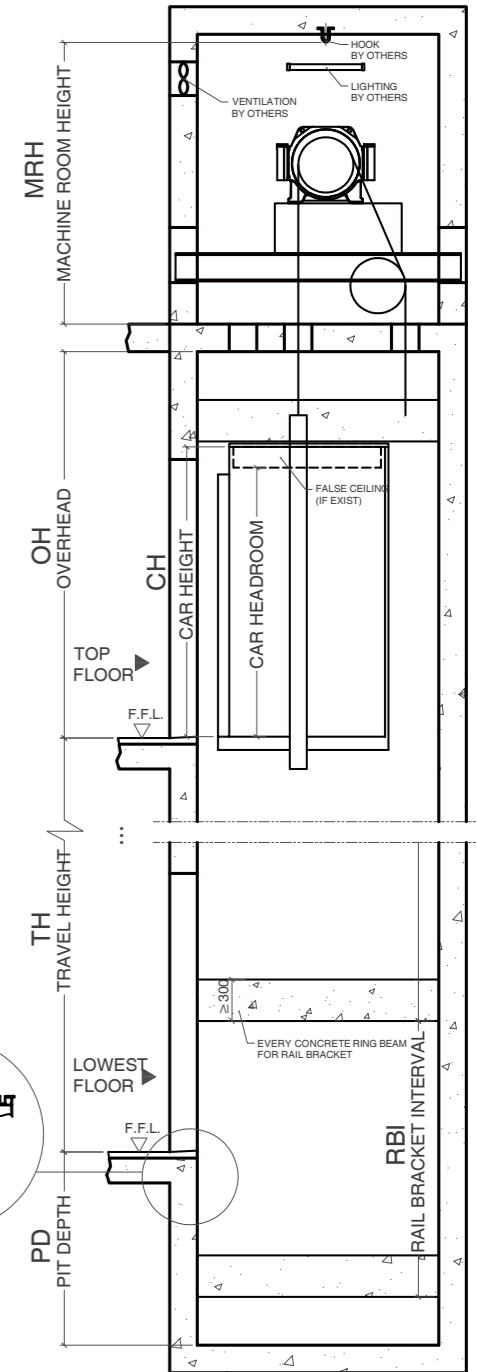

SHAFT SECTION



# PLANNING DATA

## PASSENGER LIFT / MACHINE ROOM

MLVEL-RMR EVIK-E

	CAPACITY (kg)	PERSONS	SPEED (m/s)	CAR SIZE (CWxCDxCH)	DOOR SIZE (DWxDH)	SHAFT SIZE (SWxSD)	OVERHEAD (OH)	PIT DEPTH (PD)
CWR (Counterweight at Rear)	630	8	1.0	1400x1100x2300 <sup>4)</sup>	C2 <sup>1)</sup> 800x2100	1900x1800	4600/3650 <sup>2)</sup>	1500/1200 <sup>2)</sup>
			1.5				4900/3900 <sup>2)</sup>	1700/1400 <sup>2)</sup>
			1.75				4950/4000 <sup>2)</sup>	1750/1450 <sup>2)</sup>
	800	10	1.0	1400x1350x2300	C2 800x2100	1900x2000	4000/3650 <sup>2)</sup>	1500/1200 <sup>2)</sup>
			1.5				4300/3900 <sup>2)</sup>	1700/1400 <sup>2)</sup>
			1.75				4350/4000 <sup>2)</sup>	1750/1450 <sup>2)</sup>
	1000	13	1.0	1600x1400x2300	C2 900x2100	2100x2050	4000/3650 <sup>2)</sup>	1500/1200 <sup>2)</sup>
			1.5				4300/3900 <sup>2)</sup>	1700/1400 <sup>2)</sup>
			1.75				4350/4000 <sup>2)</sup>	1750/1450 <sup>2)</sup>
	1050	14	1.0	1600x1500x2300	C2 900x2100	2100x2150	4000/3650 <sup>2)</sup>	1500/1200 <sup>2)</sup>
			1.5				4300/3900 <sup>2)</sup>	1700/1400 <sup>2)</sup>
			1.75				4350/4000 <sup>2)</sup>	1750/1450 <sup>2)</sup>
CWS (Counterweight at Side)	630	8	1.0	1100x1400x2300	C2 800x2100	1850x1850	4000/3600 <sup>2)</sup>	1200
			1.5				4300/3900 <sup>2)</sup>	1400
			1.75				4350/3950 <sup>2)</sup>	1450
	800	10	1.0	1350x1400x2300	C2 800x2100	2000x1850	4000/3600 <sup>2)</sup>	1200
			1.5				4300/3900 <sup>2)</sup>	1400
			1.75				4350/3950 <sup>2)</sup>	1450
	1000	13	1.0	1600x1400x2300	C2 900x2100	2250x1850	4000/3600 <sup>2)</sup>	1200
			1.5				4300/3900 <sup>2)</sup>	1400
			1.75				4350/3950 <sup>2)</sup>	1450
	1050	14	1.0	1600x1500x2300	C2 900x2100	2250x1950	4000/3600 <sup>2)</sup>	1200
			1.5				4300/3900 <sup>2)</sup>	1400
			1.75				4350/4000 <sup>2)</sup>	1450
	1050 (STRECHER)	14	1.0	1100x2100x2300	S2 <sup>1)</sup> 900x2100	1800x2600	4000/3600 <sup>2)</sup>	1200
			1.5				4300/3900 <sup>2)</sup>	1400
			1.75				4350/4000 <sup>2)</sup>	1450

Note:

- 1) C2 is 2 panel central opening door, S2 is 2 panel side opening door.
- 2) The 1st value is for EN81-20, the 2nd value is for EN81-1, only one value is available for both EN81-20 and EN81-1.
- 3) In case false ceiling, the overhead shall increase 150mm.
- 4) Available car height: 2100-3500mm.
- 5) Please consult the factory when there is accessible space under the pit(with cwt safety gear).

SPEED (m/s)	RISE MAX. (m)
1.0	50
1.5	75
1.75	90
2.0	110
2.5	125

## PASSENGER LIFT / MACHINE ROOM LESS

MLVEL-RML EVIN-E

	CAPACITY (kg)	PERSONS	SPEED (m/s)	CAR SIZE (CWxCDxCH)	DOOR SIZE (DWxDH)	SHAFT SIZE (SWxSD)	OVERHEAD (OH)	PIT DEPTH (PD)
CWS (Counterweight at Side)	630	8	1.0	1100x1400x2300 <sup>4)</sup>	C2 <sup>1)</sup> 800x2100	1900x1950	4000/3600 <sup>2)</sup>	1500
			1.5				4300/3900 <sup>2)</sup>	1700
			1.75				4350/4050 <sup>2)</sup>	1750
	800	10	1.0	1350x1400x2300	C2 800x2100	2150x1950	4000/3800 <sup>2)</sup>	1500
			1.5				4300/4200 <sup>2)</sup>	1700
			1.75				4350	1750
	1000	13	1.0	1600x1400x2300	C2 900x2100	2400x1950	4100	1500
			1.5				4500	1700
			1.75				4600	1750
	1050	14	1.0	1600x1500x2300	C2 900x2100	2400x2050	4200	1500
			1.5				4600	1700
			1.75				4650	1750

Note:

- 1) C2 is 2 panel central opening door, S2 is 2 panel side opening door.
- 2) The 1st value is for EN81-20, the 2nd value is for EN81-1, only one value is available for both EN81-20 and EN81-1.
- 3) In case false ceiling, the overhead shall increase 150mm.
- 4) Available car height: 2100-3500mm.
- 5) Please consult the factory when there is accessible space under the pit(with cwt safety gear).

SPEED (m/s)	RISE MAX. (m)
1.0	50
1.5	75
1.75	90



# ESCALATOR & MOVING WALK

## SAFETY PROTECTION FUNCTIONS

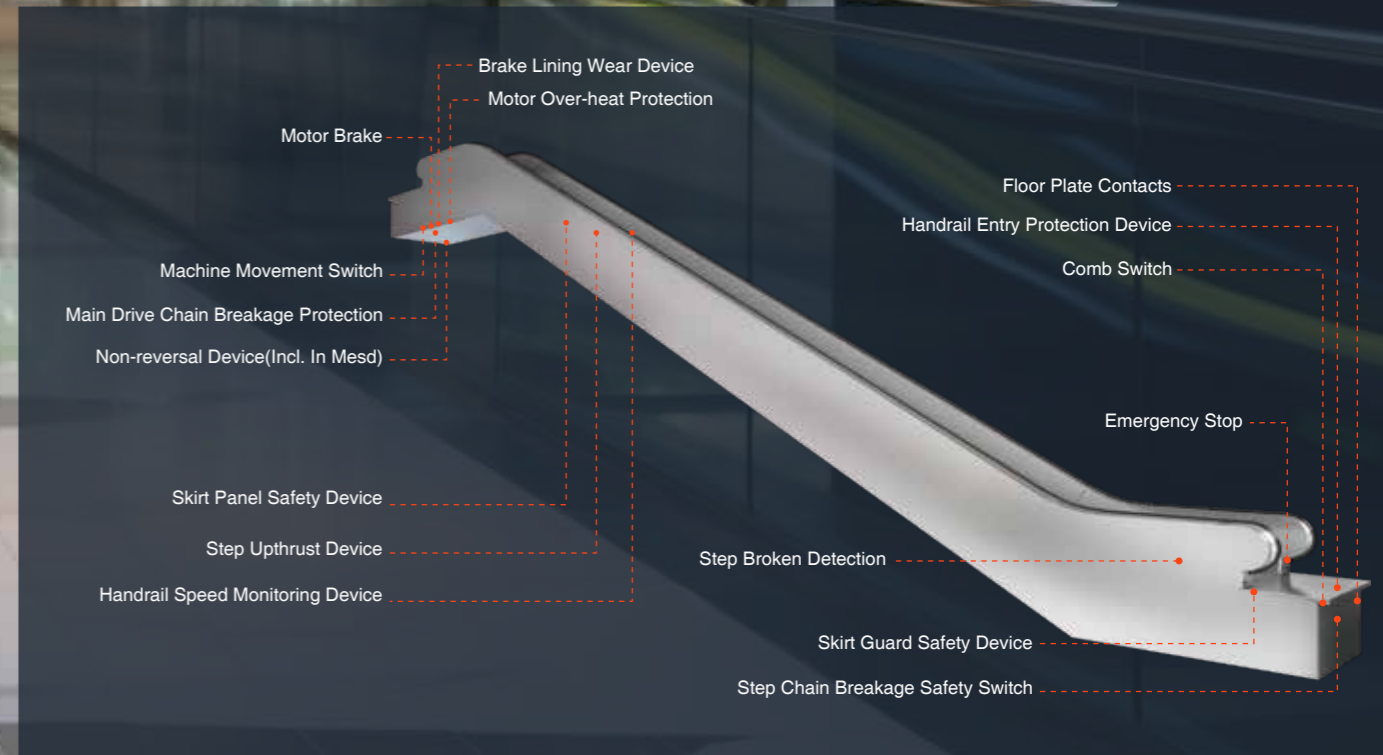



# PLANNING DATA

## ESCALATOR LTF/LTF-M

Model	Inclination (°)	Rise H(m)	Step Width A(mm)	Speed (m/s)	D		DL	UL	L	DP	UP	PIT
					D	E						
LTF	35	2 ≤ H ≤ 6	1000	0.5	1600	2240	2242	2663	1.428H+4905	4100	1.428S+6100	1100/ 1350 <sup>1)</sup>
			800		2040	2663						
			600		1840	3080						
	30	2 ≤ H ≤ 6	1000	0.5	1600	2240	2198	2567	1.732H+4765	4300	1.732S+6700	1100/ 1350 <sup>1)</sup>
			800		2040	2567						
			600		1840	2984						
		6 < H ≤ 7	1000	1600	2240	2688	3057	1.732H+5745	4800	1.732S+7200		
			800	1400	2040							
			1000	1660	2300							
		7 < H ≤ 7.8	1000	1460	2100	3474	1.732H+6162	4800	1.732S+7700			
			800	1660	2300							
			1000	1460	2100							
LTF-M	30	3 ≤ H ≤ 25	1000	0.65/0.5	1780/ 1850 <sup>2)</sup>	2490	2886/3286 <sup>2)</sup>	3551/3951 <sup>2)</sup>	1.732H+6517/ 7317/8117 <sup>3)</sup>	5010/5410 /5810 <sup>3)</sup>	1.732S+7600/ 8000/8400 <sup>2)</sup>	1305/ 1455 <sup>1)</sup>
	27.3	3 ≤ H ≤ 25	1000	0.65/0.5	1780/ 1850 <sup>2)</sup>	2490	2886/3286 <sup>2)</sup>	3551/3951 <sup>2)</sup>	1.732H+6399/ 7199/7999 <sup>3)</sup>	6000/6400 /6800 <sup>3)</sup>	1.937S+8020/ 8420/8820 <sup>2)</sup>	1305/ 1455 <sup>1)</sup>

Note:  
 1) In door=1100/1305, Out door=1350/1455. 3) 3 step/4 step/5 step, specified value refer to project drawing.  
 2) Specified value refer to project drawing. 4) Number of middle support of LTF-M refer to project drawing.

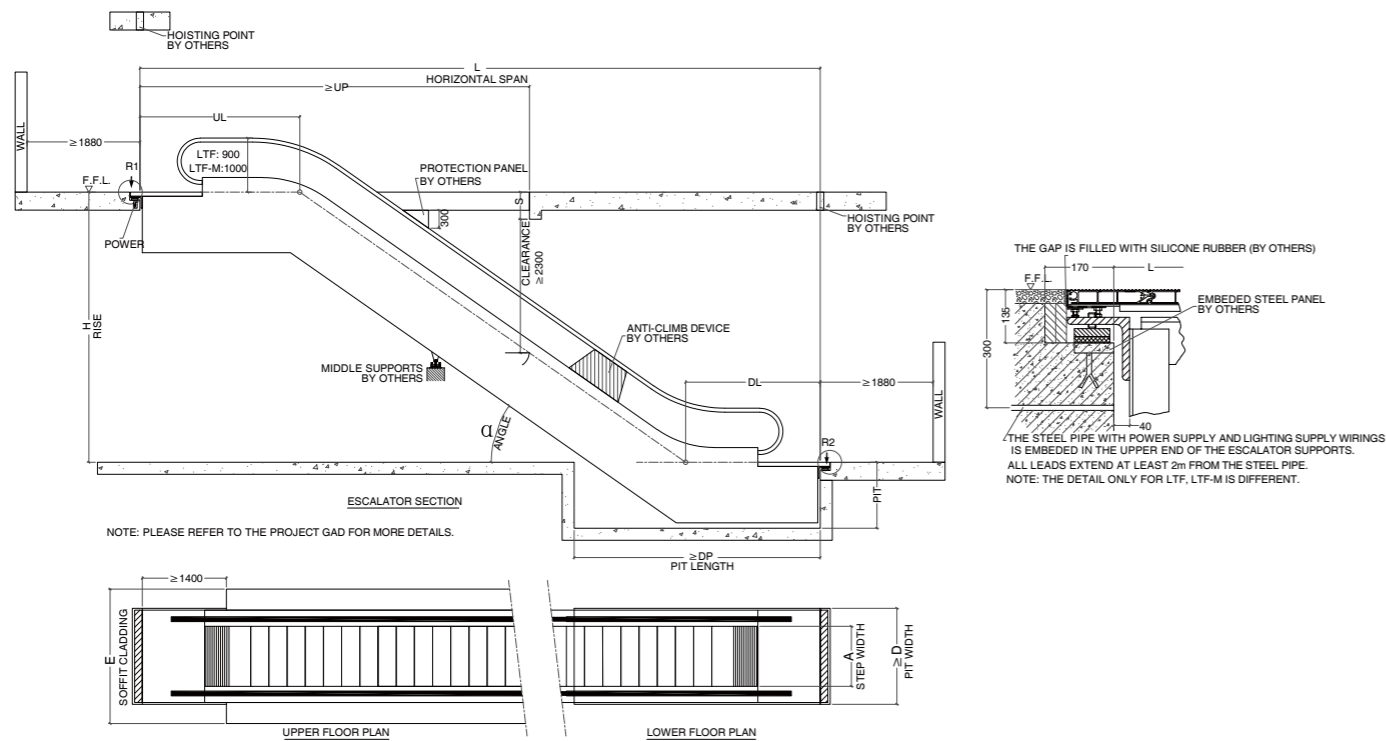

## MOVING WALK LTR

Model	Inclination (°)	Rise H(m)	Step Width A(mm)	Speed (m/s)	D		DL	UL	L	DP	UP	PIT
					D	E						
LTR	12	2.5 ≤ H ≤ 6	1000	0.5	1600	2240/3880	1056	2294	4.7046H+3350	4200	4.705S+13200	1100
			800		1400	2040/3480						
	6	H ≤ 6	1000	0.5	1600	2240/3880	-	-	10000 ≤ L ≤ 79000	=L	-	1100
LTF-M	0 / 3	-	1000	0.5	1600	2240/3880	-	-	10000 ≤ L ≤ 79000	=L	-	1100
			800		1400	2040/3480						

Note:  
 LTR is only available for in door.

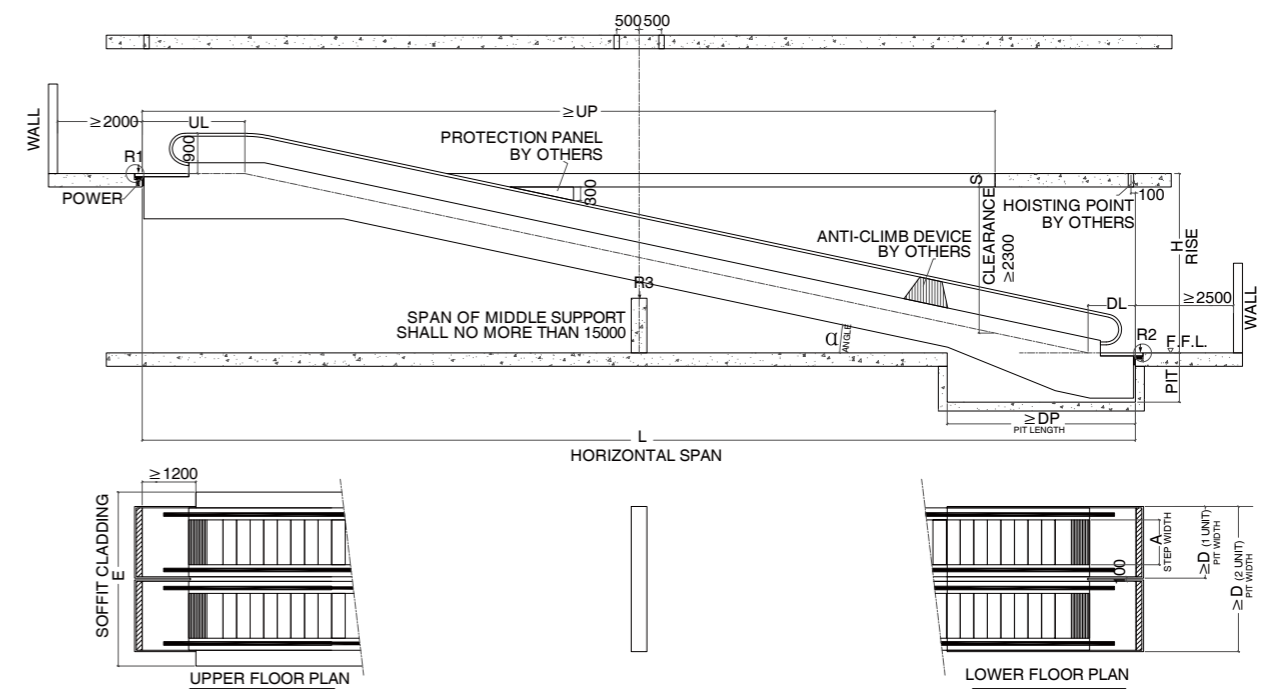



# OPTIONAL FUNCTIONS

## HANDRAIL



## SIDE RAILING



## APRON LIGHTING



## HANDRAIL ENTRANCE

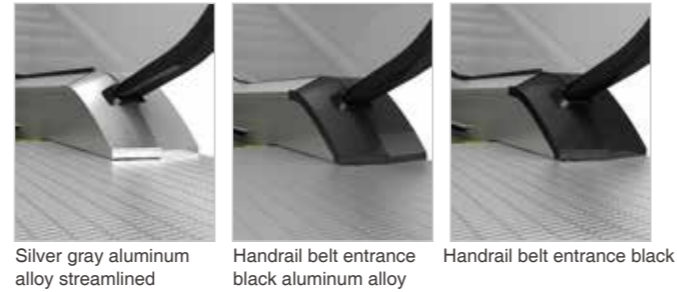

## SAFETY DEVICE



Inspection uprights are set up at the entrances and exits of escalators, and operation indicators are set on the uprights to save energy according to passenger changes



Anti creep device (Selection)  
If there is a risk of falling personnel the outer cover plate can be selected to prevent climbing up the outer side of the handrail device.



Handrail entrance  
The hidden design of handrail entrance greatly reduces the risk of caught, and embodies the design idea of multiple protection.



Built-in upper and lower handrail entrance and inside skirt pane, forming a wide range of sensing detection area, according to passenger changes to achieve energy saving.



Skirt-panel anti clamp device  
To prevent passengers from standing too close to the edge of the steps, avoid the steps will pull the foot into the gap between the stairs and the skirt panel.

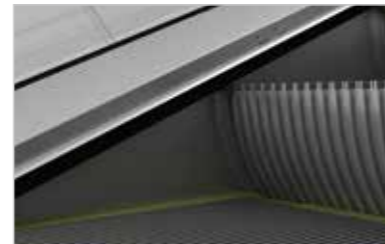

Stainless steel skirt panel  
More options, customized escalators to enhance the value of escalators.

## ESCALATOR ARRANGEMENT

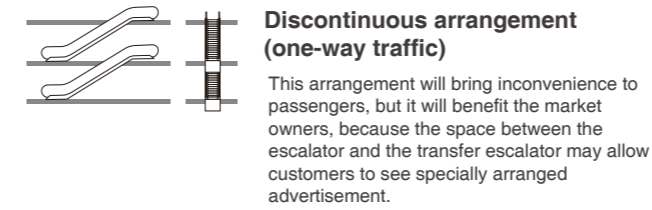

**Single Escalator**  
Use single escalator to connect two levels, it is suitable for buildings that Visitors flowrate mainly in one direction, flexible adjustments can be made to meet passenger flow needs.(for example: Up in the morning and down at night) .

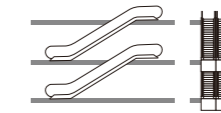

**Parallel discontinuous arrangement (two-way traffic)**  
This arrangement is mainly used in shopping malls and public transport facilities with large passenger flow. When there are three or more escalators, it should be possible to change the direction of movement in accordance with the passenger flow rate. This arrangement is economical because there is no need for thinner baffle.

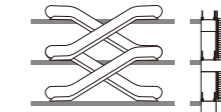

**Cross continuous arrangement (two-way traffic)**  
This arrangement is mainly used in large department stores, public buildings and chemical transport places. The transport of floors between floors should be kept as small as possible.

## MATERIAL OPTIONS

### STEP AND PALLET



Stainless steel [Indoor]  
Aluminium alloy [outdoor]

### COMB PLATE

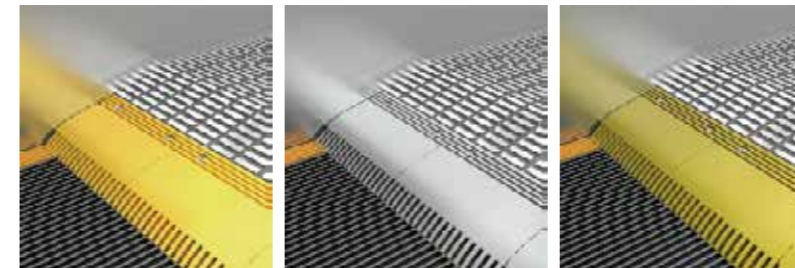

Yellow resin [Indoor] standard  
Aluminium [Outdoor] standard  
Aluminium yellow painted [optional]



# FREIGHT & CAR LIFT



## CAR DECORATION



### CAR017

#### Hairline st. st.

Ceiling: hairline st. st. + fast blowing industrial fan  
Cabin wall: hairline st. st.  
Floor: st. st. checker plate

#### Car floor

3-6mm thick high-strength steel plate, anti-skid and wear-resistant  
(stainless steel is optional)  
Reinforced car platform design to ensure durability



### CAR018

#### Powder coated RAL7032

Ceiling: powder coated + fast blowing industrial fan  
Cabin wall: powder coated steel plate RAL7032  
Floor: steel checker plate

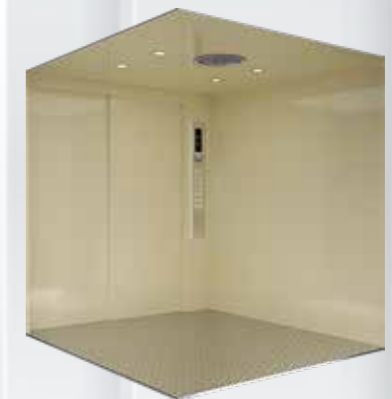

### CAR019

#### Powder coated RAL1014

Ceiling: powder coated + fast blowing industrial fan  
Cabin wall: powder coated steel plate RAL1014  
Floor: steel checker plate



# PLANNING DATA

## FREIGHT LIFT /MACHINE ROOM

### LTHX WIN1000

	CAPACITY (kg)	OPENING	CAR SIZE (CWxCDxCH)	DOOR SIZE (DWxDH)	SHAFT SIZE (SWxSD)	OVERHEAD (OH)	PIT DEPTH (PD)		
4:1 CWS (Counterweight at Side) SPEED 0.5 1.0m/s	1600	SINGLE DOOR	1700x2000x2200	S2 <sup>1)</sup> 1500x2100	2700x2600	4300	1500		
	2000	SINGLE DOOR	1600x2500x2200	S2 1400x2100	2600x3050	4300	1600		
			1800x2200x2200	S2 1500x2100	2750x2750				
			1900x2100x2200	S2 1600x2100	2900x2650				
		THROUGH DOOR	1600x2400x2200	S2 1400x2100	2600x3100				
			1800x2100x2200	S2 1600x2100	2900x2800				
			1900x2000x2200	S2 1700x2100	3050x2700				
	3000	SINGLE DOOR	2000x2800x2200	S2 1700x2100	3050x3350	4300	1600		
			2100x2600x2200	S2 1700x2100	3150x3150				
			2200x2500x2200	C4 1800x2100	3250x3050				
			2300x2400x2200	S2 1700x2100	3350x3000				
			2000x2700x2200	C4 1700x2100	3050x3400				
			2100x2500x2200	S2 1800x2100	3250x3200				
		THROUGH DOOR	2200x2400x2200	C4 1800x2100	3350x3100				
			2300x2300x2200	S2 1900x2100	3450x3000				
			2300x3100x2200	C4 2000x2100	3550x3700			4600	1800
			2400x2950x2200	C4 2000x2100	3700x3500				
			THROUGH DOOR	2050x3400x2200	C4 1700x2100				
2300x3000x2200				C4 2000x2100	3600x3700				
2400x3650x2200	C4 2100x2100	3650x4200							
5000	SINGLE DOOR	2500x3500x2200	C4 2200x2100	3750x4050	4600	1800			
		2800x3100x2200	C4 2400x2100	4200x3650					
		2400x3550x2200	C4 2100x2100	3650x4250					
	THROUGH DOOR	2500x3400x2200	C4 2200x2100	3750x4100					
		2700x3100x2200	C4 2400x2100	4100x3800					
		2800x3000x2200	C4 2400x2100	4200x3700					
6:1 SPEED 0.5m/s	6000	SINGLE DOOR	2800x3650x2200	C4 2600x2100	4500x4400	4700	1900		
	8000		3000x4500x2200	C4 2700x2100	4700x5100	4700	2000		
	10000		3000x5200x2200	C4 2800x2100	4900x5800	4700	2100		
	12000		3000x6600x2200	C4 2800x2100	5000x7200	4700	2100		
	18000		4200x7000x2700	C6 3600x2600	6100x7700	5500	2200		

Note:  
 1) S2 is 2 panel side opening door, C4 is 4 panel central opening door, C6 is 6 panel central opening door.  
 2) All values are available for code EN81-1.  
 3) Max S2 Door is 2000 width.

## FREIGHT LIFT /MACHINE ROOM LESS

### LTHW WIN1000

	CAPACITY (kg)	OPENING	CAR SIZE (CWxCDxCH)	DOOR SIZE (DWxDH)	SHAFT SIZE (SWxSD)	OVERHEAD (OH)	PIT DEPTH (PD)			
4:1 CWS (Counterweight at Side) SPEED 0.5 1.0m/s	2000	SINGLE DOOR	1900x2100x2200	S2 <sup>1)</sup> 1600x2100	3050x2650	4600	1600			
			THROUGH DOOR	1900x2000x2200	S2 1700x2100			3050x2700		
				1800x2100x2200	S2 1600x2100			2950x2800		
		SINGLE DOOR		2200x2500x2200	S2 1900x2100			3500x3050	4700	1700
			THROUGH DOOR	2200x2450x2200	S2 1700x2100			3500x3200		
				2500x2850x2200	C4 2200x2100			4050x3400		
	4000	THROUGH DOOR		2500x2750x2200	C4 2200x2100	4050x3450	5300	1800		
			2800x3100x2200	C4 2400x2100	4350x3650					
		THROUGH DOOR	2800x3000x2200	C4 2400x2100	4350x3750					
	5000		THROUGH DOOR	2500x3350x2200	C4 2400x2100	4300x4100	5300	1800		
		2800x3650x2200		C4 2500x2100	4450x4200	5500			1900	
	6000	SINGLE DOOR	2800x3650x2200	C4 2500x2100	4450x4200		5500	1900		

Note:  
 1) S2 is 2 panel side opening door, C4 is 4 panel central opening door, C6 is 6 panel central opening door.  
 2) All values are available for code EN81-1.  
 3) Max S2 Door is 2000 width.



# STANDARD CONFIGURATION



COP022



## Landing door

Door jamb: powder coated/hairline st. st.  
Door panel: powder coated/hairline st. st.



LOP028

# LTC



LOADING ENTRY: WINDOW



LOADING ENTRY: FLOOR



## PLANNING DATA

	CAPACITY (kg)	SPEED (m/s)	LOADING ENTRY	CAR SIZE (CWxCDxCH)		SHAFT SIZE(SWxSD)		OVERHEAD (OH)	PIT DEPTH (PD)
				CWS	CWR	CWS	CWR		
DUMBWAITER / LTC (machine room less)	100	0.4	WINDOW	600x600x800	1000x1000	1160x920	3600	0	
				600x700x800	1000x1100	1160x1020			
				700x700x800	1100x1100	1260x1020			
				700x800x800	1100x1200	1260x1120			
				750x750x800	1150x1150	1310x1070			
	200	0.4	FLOOR	800x800x800	1200x1200	1360x1120	3600	800	
				800x800x1000	1200x1200	1360x1120			
				800x900x1000	1200x1300	1360x1220			
				900x900x1000	1300x1300	1460x1220			
				1000x1000x1000	1400x1400	1560x1320			
300			1000x1000x1200 <sup>2)</sup>	1400x1400	1560x1320				

CWS (counterweight at side)

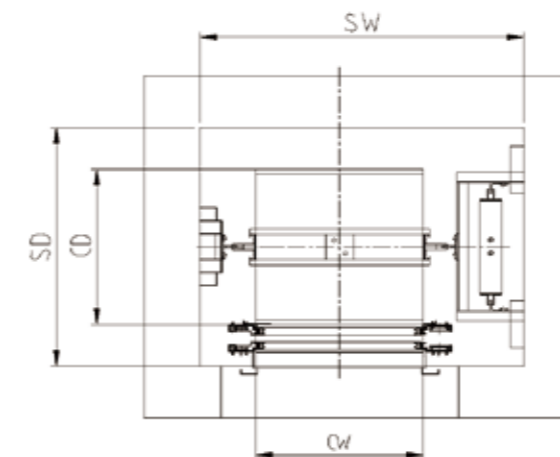

CWR (counterweight at rear)

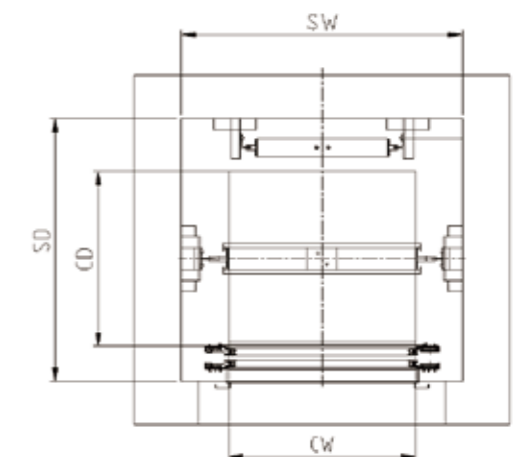



SOUTHEAST ASIA



**SBH KIBING SOLAR NEW MATERIAL(M) SDN.BHD**  
Malaysia  
Elevator 12 units (Include CE 18tons)



**T & W VIETNAM**  
Vietnam  
Elevator 11 units (include 10tons)  
Escalator 2 units (10m height)



**SAMANEA CAMBODIA PHNOM PENH LIGHT INDUSTRY PARK**  
Cambodia  
Elevator 25 units



**FOINIX CENTER**  
Manila, Philippines  
Passenger Elevator 14 units  
Escalator 16 units



**HUALIDA VIETNAM (QUANG NINH) HOLDINGS LIMITED**  
Vietnam  
Freight Elevator 22 units

SOUTHEAST ASIA



**REGINA MIRACLE INTERNATIONAL (VIETNAM) LIMITED**  
Haiphong, Vietnam  
Passenger Elevator 14 units  
Freight Elevator 33 units



**AMPACS INTERNATIONAL**  
Binh Duong, Vietnam  
Passenger Elevator 1 units  
Freight Elevator 13 units



**FLAT GLASS GROUP**  
Binh Duong, Vietnam  
Passenger Elevator 2 units  
Freight Elevator 2 units



**INCHOI**  
Phillippines  
Elevator 6 units (more than 30F)



**SUNWAY GROUP PROJECT**  
Kuala Lumpur, Malaysia  
Escalator 8 units



AFRICA



**ADDIS AFRICA INTERNATIONAL CONVENTION AND EXHIBITION CENTER**  
Ababa, Ethiopia  
Passenger elevator 2 units  
Escalator 4 units



**GHANA HOTEL**  
Accra, Ghana  
Passenger elevator 2 units



**HUAJIAN GROUP EASTEN INDUSTRIAL ZONE**  
Addis ababa, Ethiopia  
Freight elevator 12 units



**TEEJAY ESTATE**  
Nairobi, Kenya  
Passenger Elevator 4 units



**DAINTY APARTMENT**  
Nairobi, Kenya  
Passenger elevator 2 units



**COPTIC HOSPITAL KENYA**  
Kenya  
Passenger elevator 2 units



**SYNAGOGUE CHURCH OF ALL NATIONS**  
Lagos, Nigeria  
Passenger elevator 4 units



**ADDIS ABABA**  
Ethiopia  
Passenger Elevator 2 units  
Escalator 4 units



**LEMIGO HOTEL**  
Kigali, Rwanda  
Passenger elevator 6 units



**BOMAH HOTEL**  
Uganda  
Passenger elevator 6 units



**SENANA SHOPPING CENTER**  
Uganda  
Passenger elevator 4 units,  
escalator 6 units



**COPTIC HOSPITAL NIGERIA**  
Kampala, Uganda  
Passenger elevator 6 units



**GARDEN TOP HOTEL**  
Nigeria  
Passenger elevator 4 units



AFRICA



**HORMUUD HAWL WADAAG**  
Somalia  
Passenger elevator 2 units



**RAYAN BUSINESS CENTER**  
Somalia  
Passenger elevator 6 units



**DAARUSALAM APARTMENTS**  
Somalia  
Passenger elevator 6 units



**AL NASIRIYAH TEACHING HOSPITAL**  
Iraq  
Passenger elevator 6 units

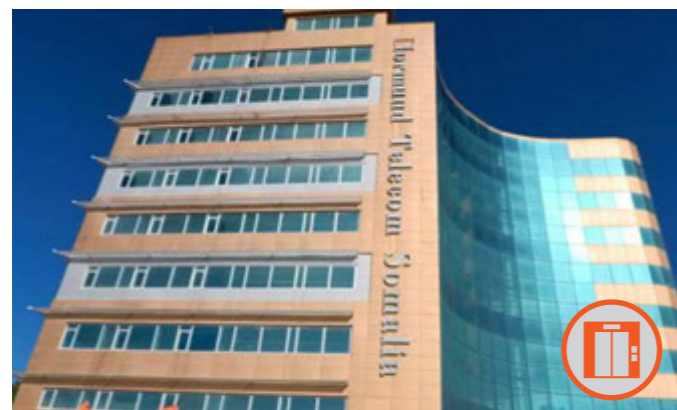

**HORMUUD TELECOM**  
Mogadishu, Somalia  
Passenger Elevator 4 units



**HUMMUND UNIVERSITY**  
Somalia  
Passenger elevator 2 units

MIDDLE EAST AND SOUTH ASIA



**ROYAL MALL**  
Royal Mall, Pakistan  
Passenger Elevator 8 units



**UTTARA SQUARE SHOPING CENTER**  
Bangladesh  
Passenger elevator 4 units  
Escalator 14 units



**THE GALLERIA**  
Pakistan  
Passenger Elevator 6 units  
Escalator 12 units



**AL NASIRIYAH TEACHING HOSPITAL**  
Iraq  
Passenger elevator 6 units



**ASMAT ALI KHAN CENTRAL HOSPITAL**  
Dhaka, Bangladesh  
Hospital Elevator 4 units



**DOMINION**  
Dominion, Pakistan  
Passenger Elevator 18 units  
Escalator 34 units



RUSSIAN AREA AND OTHERS



**ПЛЕХАНОВА**  
Russia Moscow  
Elevator 4 units



**LYUBERTSY, GOGOL 3**  
Russia Moscow  
Passenger elevator 12 units



**БЛАГОСТРОЙ 207**  
Russia  
Passenger elevator 4 units



**FJORD PLAZA**  
Pskov, Russia  
Passenger Elevator 4 units  
Escalator 4 units



**MEGA DOSTYK PLAZA**  
Kazakhstan  
Escalator 2 units



**TASHIKENT BRIGHT PEARL PROJECT**  
Uzbekistan  
Passenger Elevator 8 units



**MTSVANE KONTSKHI**  
Georgia, Batumi,  
Mtsvane Kontskhi  
Passenger elevator 3 units



**TBILISI**  
Georgia, Tbilisi, Vazisubani  
Passenger elevator 2 units



**HZ MALL**  
Venezuela  
Passenger elevator 2 units  
Escalator 8 units

CHINA



**TIBET RAILWAY SECTION**  
Tibet, China  
Passenger elevator 31units  
Escalator 6units



**GUANGZHOU METRO STATION**  
Guangzhou, China  
Line 7 & 13 Passenger elevator 45units



**FU NING GARDEN(HONG KONG)**  
Hong Kong, China  
Passenger Elevator 16 units



**MEIJING RESIDENTIAL**  
Macau, China  
Passenger Elevator 18 units