

13C202403

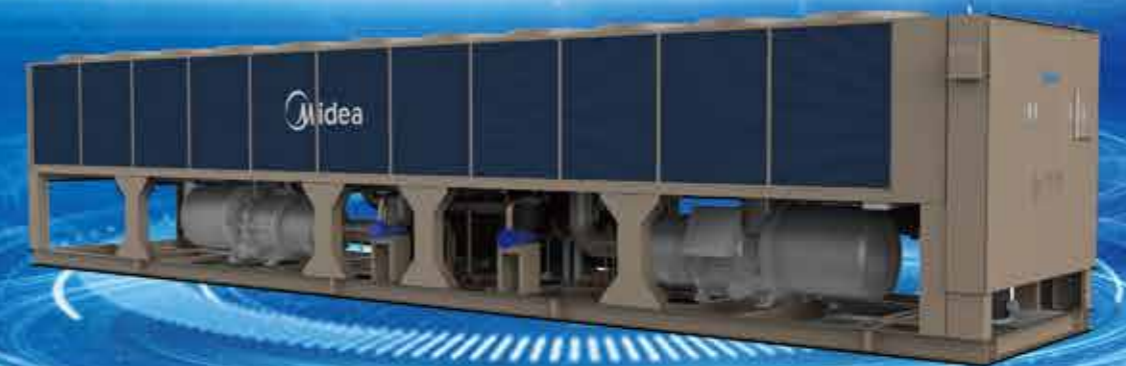

Flooded Air Cooled Screw Chiller SCAG***H



Midea Building Technologies Division
Midea Group

Add.: Midea Headquarters Building, 6 Midea Avenue, Shunde, Foshan, Guangdong, China
Postal code: 528311

mbt.midea.com www.midea-group.com tsp.midea.com

Midea reserves the right to change the specifications of the product, and to withdraw or replace products without prior notification or public announcement. Midea is constantly developing and improving its products.



2024

MAKE A BEAUTIFUL TOMORROW

Midea MBT

Midea MBT(Midea Building Technologies) is a key division of the Midea Group, a leading provider of comprehensive solutions of intelligent building, involving energy sources, elevators, control systems, and heating, ventilation & air conditioning. Midea MBT has continued with the tradition of innovation upon which it was founded and emerged as a global leader in the HVAC and building management industry. A strong drive for advancement has resulted in an extensive R&D department that has placed Midea MBT at the forefront of a competitive edge. Through these independent projects and joint-cooperation with other global enterprises, Midea has supplied thousands of innovative solutions to customers worldwide.

Several production bases are situated on Shunde, Chongqing, Hefei, and Italy.

MBT Shunde: 38 product lines focusing on VRF, Split Products, Heat Pump Water Heaters and AHU/FCU.

MBT Chongqing: 14 product lines focusing on Water Cooled Centrifugal/Screw/Scroll Chillers, Air Cooled Screw/Scroll Chillers and AHU/FCU.

MBT Hefei: 11 product lines focusing on VRF, Chillers and Heat Pump Water Heaters.

Clivet S.p.A: 50,000m2 workshop in Feltre and Verona, covering products such as ELFO system, hydronic, WHLP, packaged, split and close control and so on.



MBT Learning Academy



Objective

MBT Learning Academy aims to provide training to the sales personnel as well as technical personnel in order to increase the utilization for your MBT equipment. Once you have purchased equipment from MBT, taking care of the equipment is topmost priority. MBT Learning Academy offers training courses to learn firsthand from the manufacturer what it takes to get the best out of your MBT product. The goal of MBT Learning Academy is to provide product specific training, safe work procedures and expertise in carrying out the installation and maintenance of MBT products as well as teaching the main selling points in order to help the sales people sell the MBT products with ease.

Training Centers

Our world class training centers provide knowledge and skills necessary to efficiently deploy MBT technologies. The training centers include dedicated laboratories to provide hands-on experiences with various systems, components and controls to refresh and enhance the skills of your sales, design and installation and service teams. Right now we operate our trainings from the below two locations:

1. MBT Training Center

Address: MBT Training Center, 2nd Floor, Building 6, Midea Global Innovation Center, Beijiao, Shunde, Foshan, China Pin-528311

The Midea MBT Training Center is situated 70 kilometers from Baiyun Guangzhou International Airport.

Products: VRF, M thermal

2. Chongqing Midea Training Center

Address: No. 15, Qiangwei Road, Nan'an District, Chongqing, China

Chongqing Midea Training Center is 35 kilometers from Chongqing International Airport.

Products: Centrifugal Chiller, Screw/Scroll Chiller and Terminals



VRF training



M thermal training



Chiller training

Global Technical Trainings

The training courses by MBT Learning Academy are divided into the following two categories with different targeted audiences for each.

Design and Application Trainings: The design and application trainings for various products are basically for the sales personnel selling MBT products in order to give them basic understanding about the main features. The trainings are conducted on a global level inviting sales engineers, technical engineers, consultants and project designers from different parts of the world.

After Sales- Service Trainings: These trainings are dedicated for the After Sales/ Service personnel in order for them to better carry out the installation, commissioning and maintenance of MBT products. Technical person and engineers from different parts of the world are invited to take part in these trainings.

Online Trainings: The trainings to the Global customers can also be done online with the help of Team and Midea Meeting software. This way, the customers do not need to be physically present for the training. Amid the COVID-19 pandemic, MBT Learning Academy has conducted a lot of online trainings. The training videos are available on the TSP system and can be downloaded by using QR codes.

Products: VRF, M thermal, Chillers and Terminals

Highly Skilled Trainers: The trainers for various courses by MBT Learning Academy are expert people with vast experiences in their field. Most of them have a deep insight about the global HVAC market and help the attendees to better understand the MBT products.

Training Certificates:

The attendees for Global trainings are provided a training certificate highlighting the courses discussed in the training, signed by Mr. Henry Cheng, General Manager of MBT Overseas Sales Company.

Registration:

You can contact your respective Midea contact point to provide you with the complete schedule about the global technical trainings as well as how to register for these trainings.

For further enquiries about the Global Trainings conducted by MBT Learning Academy, please send email at the following email address: peeyush@midea.com



Chiller After Sales Courses



Chiller Introduction Courses

Midea Global Spare Parts Center

The global spare parts center provides high quality and fast spare parts supply. Midea online system (<https://tsp.midea.com>) can query and purchase spare parts with one click, further shortening the supply time of spare parts.

The “2 (HQ Spare parts center) + 10 (Regional Spare parts center) + N (Country Spare parts inventory)” Spare Parts Layout can ensure the timely supply of global after-sales spare parts.



Content

08 Overview

09 Features

12 Specifications

14 Dimensions and base diagrams

22 Installation and maintenance

26 Options

27 Intelligent management

29 Reference projects

Overview

Midea flooded air cooled screw chiller adopts high efficiency semi-hermetic twin-rotor screw compressor, high efficiency evaporator and high efficiency inverted M-type fin-coil heat exchanger, through the EXV control technology, the unit can meet the needs of users in energy-saving mode within the working range. The unit adopts R134a environmentally friendly refrigerant. The products can be widely used in large and medium-sized commercial, civil or industrial buildings, and can also be used in areas with heavy anti-corrosion (optional).

Nomenclature

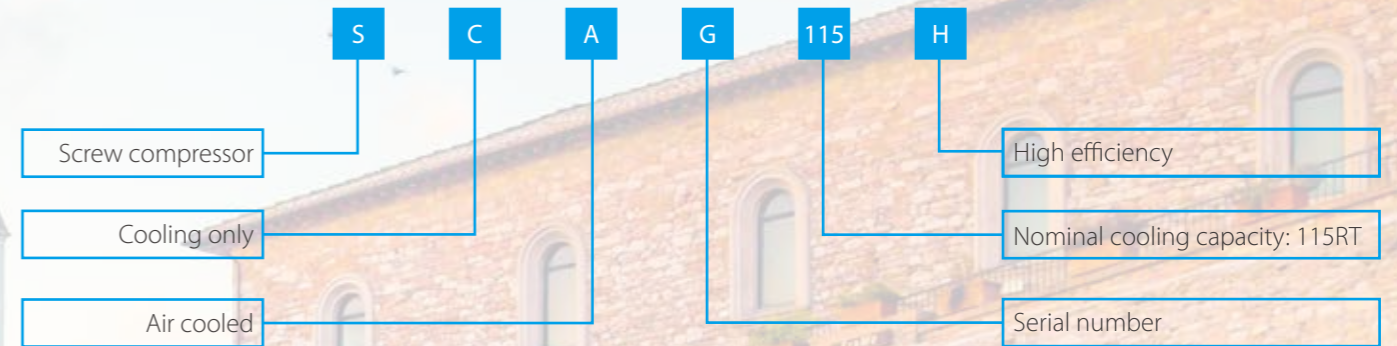

Operating range

Operating condition	Cooling
Ambient temperature	10°C~43°C
Water outlet temperature	5°C~20°C

Unit member

High efficiency fan
Metal blade, large air volume.

Fin-coil condenser
Window type hydrophilic aluminum fins,
high efficiency inner-threaded tube.

Flooded evaporator

EXV

Integrated starter panel and control panel

The starter panel is equipped with circuit breaker. The control panel is low-voltage power supply.

Built-in touch screen
7-inch colorful touch screen

Double oil separation
Compressor filter + centrifugal oil separation, oil rate of heat exchanger is below 0.03%.

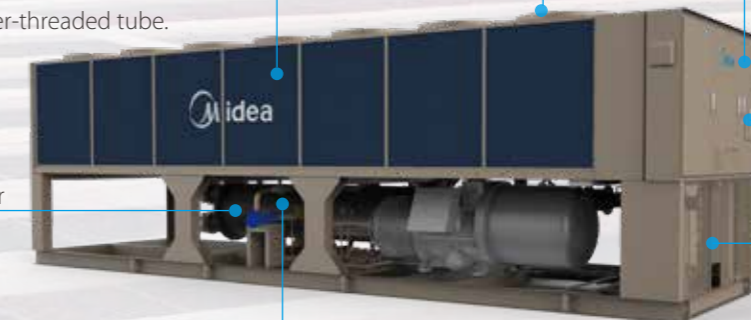

Features

High Efficiency

High efficiency screw compressor



- ❖ The screw rotor adopts the optimized compression process profile design, not only ensures excellent volume efficiency, but also reduces the leakage of the compressor. The twin screw rotor adopts five teeth to six teeth asymmetrical design, the machining accuracy is as high as micron level, stable and reliable.
- ❖ Refrigerant-cooled large capacity motor design, high motor efficiency. The screw rotor is driven by motor directly, less moving parts and wearing parts, high mechanical efficiency.
- ❖ Compressor adopts high efficiency bearing, high load resistance design, proprietary reverse bearing and balance axial thrust balance drum design, can effectively prolong the service life of the compressor and ensure the continuous operation of the chiller ≥ 50000 hours.
- ❖ The new protection module provides complete electrical protection for reverse and lose phases, and provides real-time temperature detection of motor winding and discharge temperature detection, and has the function of fault self-locking to ensure the safety of compressor operation.

High efficiency air side heat exchanger

- ❖ Inverted M-type air-side heat exchanger, the airflow is evenly distributed to achieve high efficiency heat exchange.
- ❖ High efficiency inner-threaded pipes and high quality arc-shaped window aluminum fins are closely combined by mechanical expansion pipe to improve heat transfer efficiency, reduce pressure loss and wind noise.
- ❖ Professional temperature field simulation, optimized design.

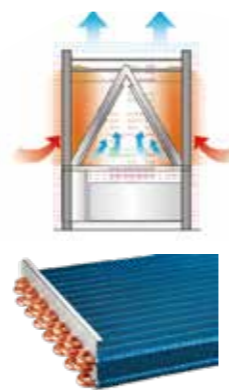

High efficiency flooded evaporator

- ❖ The refrigerant distributor can distribute refrigerant evenly, optimize the temperature field and improve the evaporation temperature, so as to improve the operating efficiency.
- ❖ Specially designed baffle plate to avoid the compressor suction with liquid, improving the reliability of the unit.
- ❖ The water box at both ends can be disassembled to facilitate maintenance.

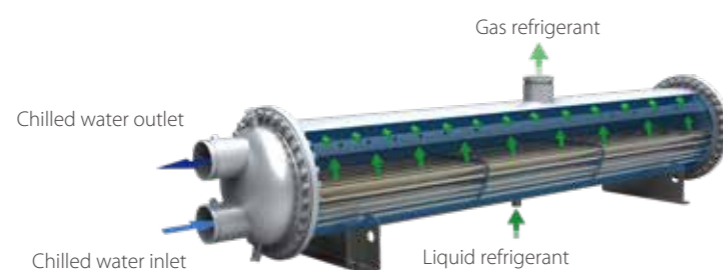

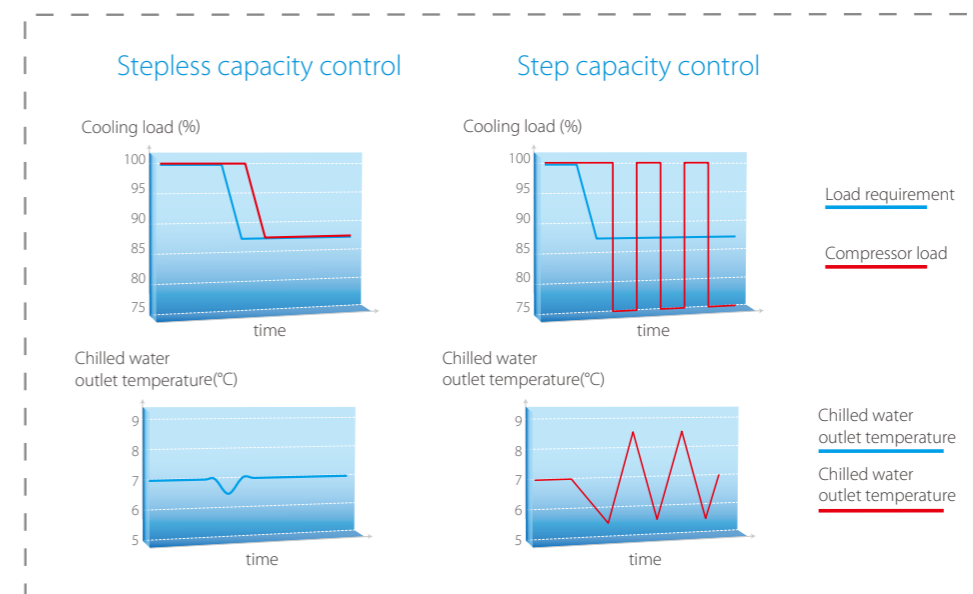

Stepless Capacity Control

Through high-precision capacity control, the load change of the unit is closely tracked, and the refrigerant flow is adjusted. The capacity adjustment mode adopts stepless control, the refrigerating capacity is completely matched with the load, the unit still keeps efficient operation at partial load, and the outlet water temperature of the unit is stable, thus enhancing the user experience.



High precision EXV

- ❖ The unit adopts electronic expansion valve to control the refrigerant flow accurately, which has fast response speed and quick adjustment, greatly improves the energy saving and stability of the unit and reduces the operation cost.
- ❖ Autonomous control to ensure accurate linkage between electronic expansion valve and unit.

High precision EXV	Traditional thermal expansion valve
	
	
The hysteresis of refrigerant control is eliminated, and the compressor is always running in good condition.	The refrigerant control lags behind, the stability of the unit is not good, and the operation cost is high.

Reliable Operation, Easy Installation

- ❖ Each unit adopts 1 ~ 2 compressors, and a single compressor is equipped with an independent refrigeration circuit. Compressors of double circuit system units can be used as standby each other, and multiple compressor units can automatically balance the running time of each compressor, balance the work of each unit and prolong the life of the whole system.
- ❖ Flexible design. The units can be modularized and freely combined, easily expanded, and the free cooling capacity matching and centralized control of 8 units can be achieved. It can respond flexibly and output on demand according to different space needs.
- ❖ Flexible installation. There is no need to set up a special equipment room or purchase cooling water tower, cooling water pump and other equipment.
- ❖ Integrated design of unit electrical control and the chiller, so users don't need to set up special electric control panel.

Specifications

Model		SCAG115H	SCAG135H	SCAG170H	SCAG195H	SCAG210H	SCAG245H	SCAG280H	
Cooling capacity	RT	113.8	136.7	169.8	195.0	212.5	245.8	281.6	
	kW	400.2	480.7	596.9	685.8	747.2	864.3	990.1	
Power input	kW	119.9	154.6	196.4	223.7	243.8	276.4	304.9	
Cooling COP	W/W	3.337	3.109	3.038	3.066	3.064	3.126	3.247	
IPLV	W/W	4.319	4.155	4.094	4.100	4.123	4.152	4.203	
Cooling capacity	Quantity	1							
	Type	Semi-hermetic twin-rotor screw compressor							
	Energy regulation mode	Stepless control (25%~100%)							
	Starting method	Wye-Delta							
Refrigerant	Type	R134a							
	Charge amount	kg	113.0	118.0	151.0	177.0	191.0	214.0	235.0
Power supply	/	380V-3Ph-50Hz							
Air side	Type	Fin-coil							
	No. of fan	/	6	6	8	10	12	12	14
heat exchanger	Air flow	m ³ /h	23000 × 6	23000 × 6	23000 × 8	23000 × 10	23000 × 12	23000 × 12	23000 × 14
	Motor power input	kW	2.4 × 6	2.4 × 6	2.4 × 8	2.4 × 10	2.4 × 12	2.4 × 12	2.4 × 14
Water side	Type	Shell and tube							
	Water flow	m ³ /h	68.58	82.37	102.3	117.5	128.0	148.1	169.7
	Water side pressure drop	kPa	42.7	46.3	70.4	79.2	73.4	76.6	67.3
heat exchanger	Water pipe connection	mm	DN150	DN150	DN150	DN150	DN150	DN200	DN200
Unit dimensions	Length	mm	4220	4220	5055	6060	7065	6835	7840
	Width	mm	2300	2300	2300	2300	2300	2300	2300
	Height	mm	2460	2460	2460	2460	2460	2460	2460
Shipping weight	kg	3700	4300	4900	5550	5950	6750	7300	
Running weight	kg	3850	4470	4990	5770	6190	7020	7590	

Note:
 1. Performance and efficiency are based on AHRI 551/591.
 Cooling: chilled water inlet/outlet=12°C/7°C; fouling factor=0.018 m²·°C/kW, outdoor ambient temperature 35°C DB.
 2. As a result of the continuous improvement of the product, the above parameters may be changed, please refer to the product nameplate and in-kind.

Green and Low Noise

- ❖ The whole series of units adopt R134a eco-friendly refrigerant, which has high refrigeration efficiency and no damage to the atmospheric ozone layer.
- ❖ Screw compressor is semi-closed structure, driven by direct motor, with low speed and low noise.
- ❖ Low noise option can be selected to further reduce the noise value of the unit by 2 ~ 3 dBA.

High efficiency and large air volume fan

- ❖ The impeller of the fan is optimized by professional flow field software, which ensures that the impeller has good aerodynamic performance, obtains greater air volume while ensuring the low noise operation, and improves the heat transfer effect on the air side.
- ❖ Through the optimization design of the motor coil, the motor of the fan can effectively reduce the loss and improve the operation efficiency, so that the motor has less heat, less power consumption and long operation life.

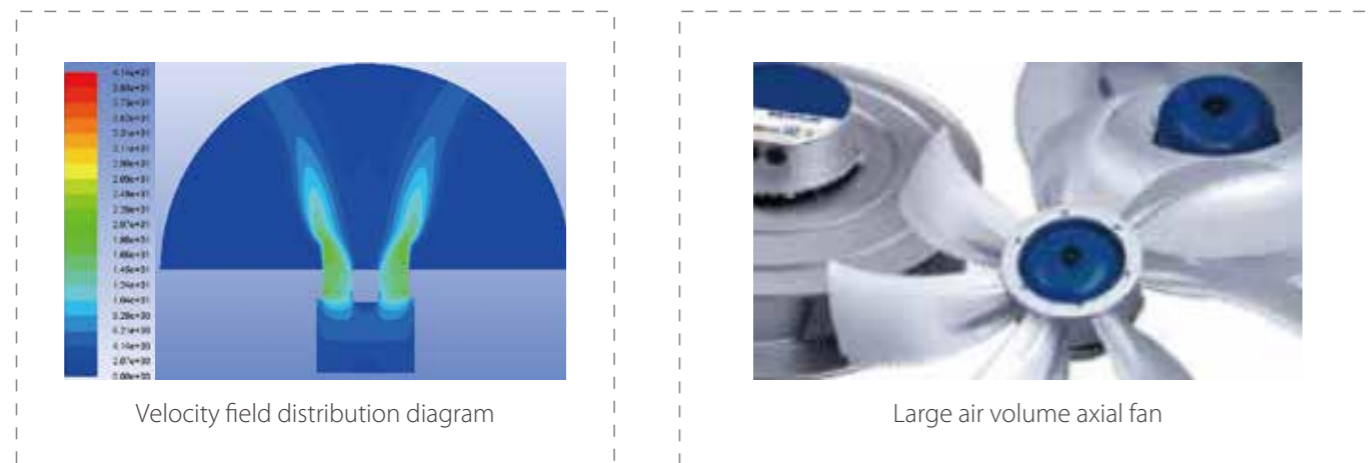

Intelligent Control

It is controlled by microcontroller, and has many automatic control functions such as fault diagnosis, antifreeze monitoring, etc., which ensures the efficient operation and convenient operation of the unit. The unit has its own RS485 communication interface, and multiple units can implement multi-communication control; The unit can be controlled by the upper computer. The operation of each unit can be controlled by the upper computer according to the load demand and operation time.

- ❖ Control mode: MIC
- ❖ Interface display: 7-inch touch screen
- ❖ Communication interface: RS485
- ❖ Communication protocol: Modbus-RTU
- ❖ Protection measures: more than 20 items of protection such as power supply, compressor, pressure and temperature

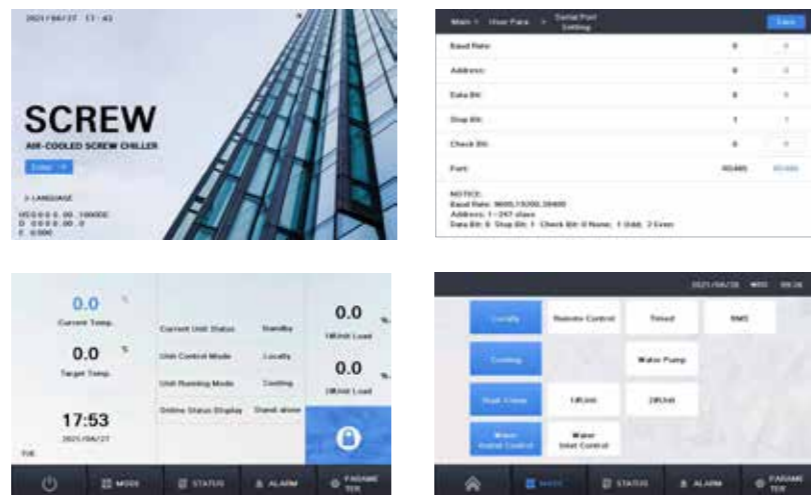

Dimensions and Base Diagrams

Dimensions

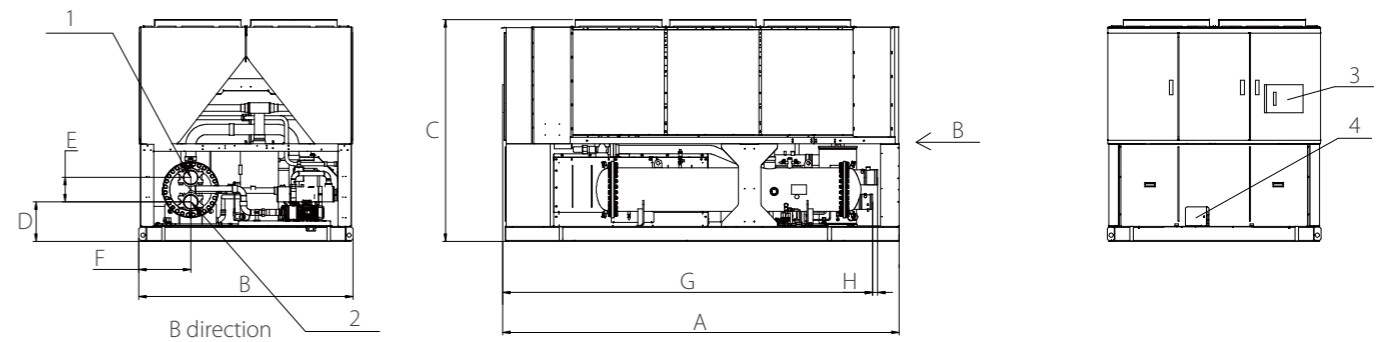

① Chilled water outlet ② Chilled water inlet ③ Control panel ④ Power incoming line

Dimensions (unit: mm)

Model	A	B	C	D	E	F	G	H
SCAG115H	4225	2300	2460	420	260	550	3940	50
SCAG135H	4225	2300	2460	420	260	480	4015	50

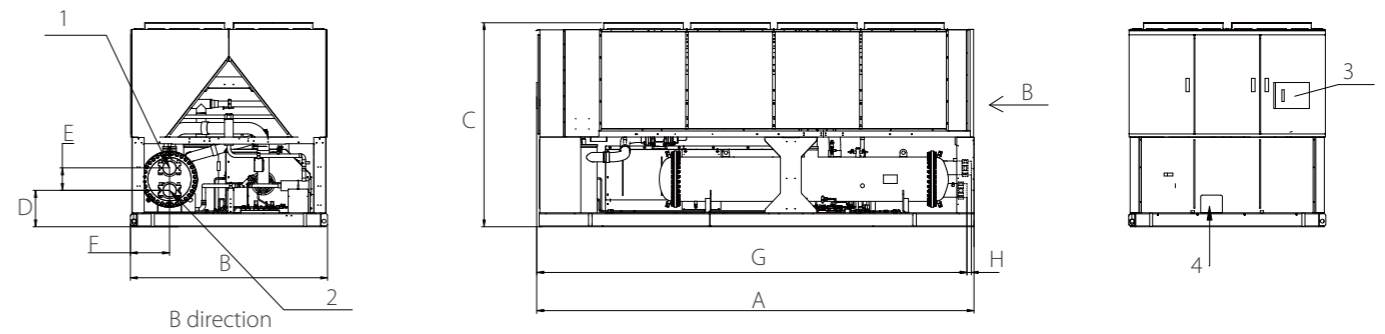

① Chilled water outlet ② Chilled water inlet ③ Control panel ④ Power incoming line

Dimensions (unit: mm)

Model	A	B	C	D	E	F	G	H
SCAG170H	5055	2300	2460	420	260	450	4975	50

Model		SCAG295H	SCAG335H	SCAG380H	SCAG420H	SCAG480H	
Cooling capacity	RT	294.5	334.6	379.4	418.5	481.3	
	kW	1035	1176	1333	1471	1692	
Power input	kW	333.6	378.9	441.6	473.9	539.8	
Cooling COP	W/W	3.104	3.105	3.021	3.105	3.135	
IPLV	W/W	4.242	4.219	4.227	4.218	4.230	
Cooling capacity	Quantity	2					
	Type	Semi-hermetic twin-rotor screw compressor					
	Energy regulation mode	Stepless control (12.5%~100%)					
	Starting method	Wye-Delta					
Refrigerant	Type	/					
	Charge amount	kg	156+161	164+169	176+182	202+207	200+215
Power supply	/	380V-3Ph-50Hz					
Air side	Type	/					
	No. of fan	/	16	18	20	20	22
heat exchanger	Air flow	m ³ /h	23000 × 16	23000 × 18	23000 × 20	23000 × 20	23000 × 22
	Motor power input	kW	2.4 × 16	2.4 × 18	2.4 × 20	2.4 × 20	2.4 × 22
Water side	Type	/					
	Water flow	m ³ /h	177.4	201.6	228.6	252.2	290.0
	heat exchanger	Water side pressure drop	kPa	68.9	76.6	75.8	75.5
	Water pipe connection	mm	DN200	DN200	DN200	DN200	DN200
Unit dimensions	Length	mm	8865	9870	10875	10875	11880
	Width	mm	2300	2300	2300	2300	2300
	Height	mm	2460	2460	2460	2460	2460
Shipping weight	kg	9100	9600	10900	11400	13540	
Running weight	kg	9450	9970	11290	11800	14040	

Note:
 1. Performance and efficiency are based on AHRI 551/591.
 Cooling: chilled water inlet/outlet=12°C/7°C; fouling factor=0.018 m²·°C/kW, outdoor ambient temperature 35°C DB.
 2. As a result of the continuous improvement of the product, the above parameters may be changed, please refer to the product nameplate and in-kind.

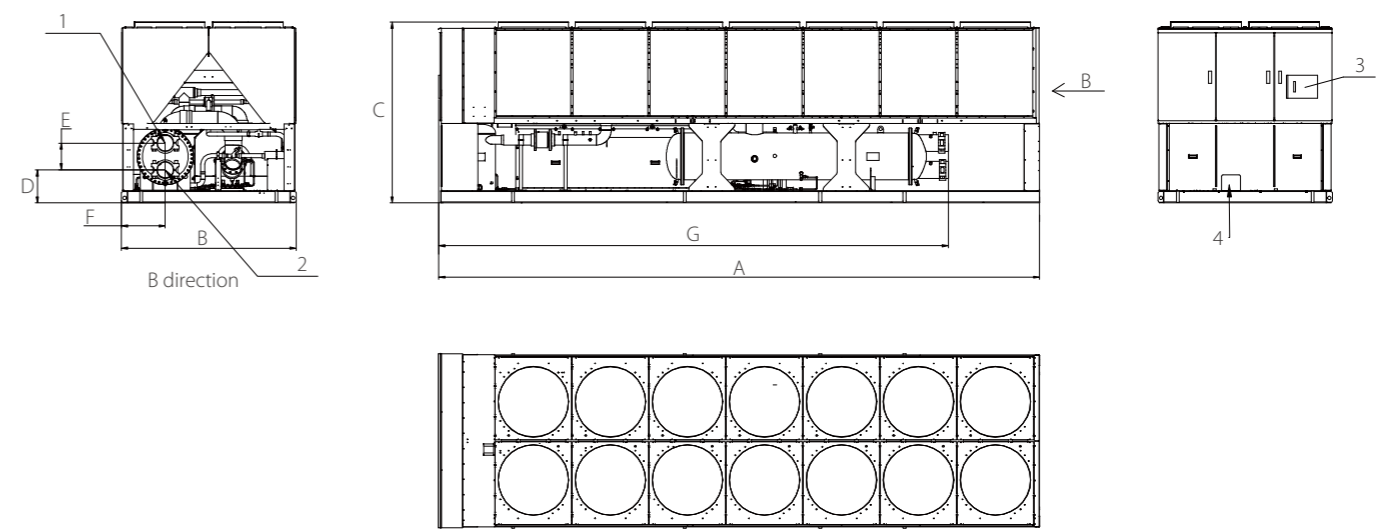

① Chilled water outlet ② Chilled water inlet ③ Control panel ④ Power incoming line

Dimensions (unit: mm)

Model	A	B	C	D	E	F	G
SCAG280H	7840	2300	2460	430	350	570	6650

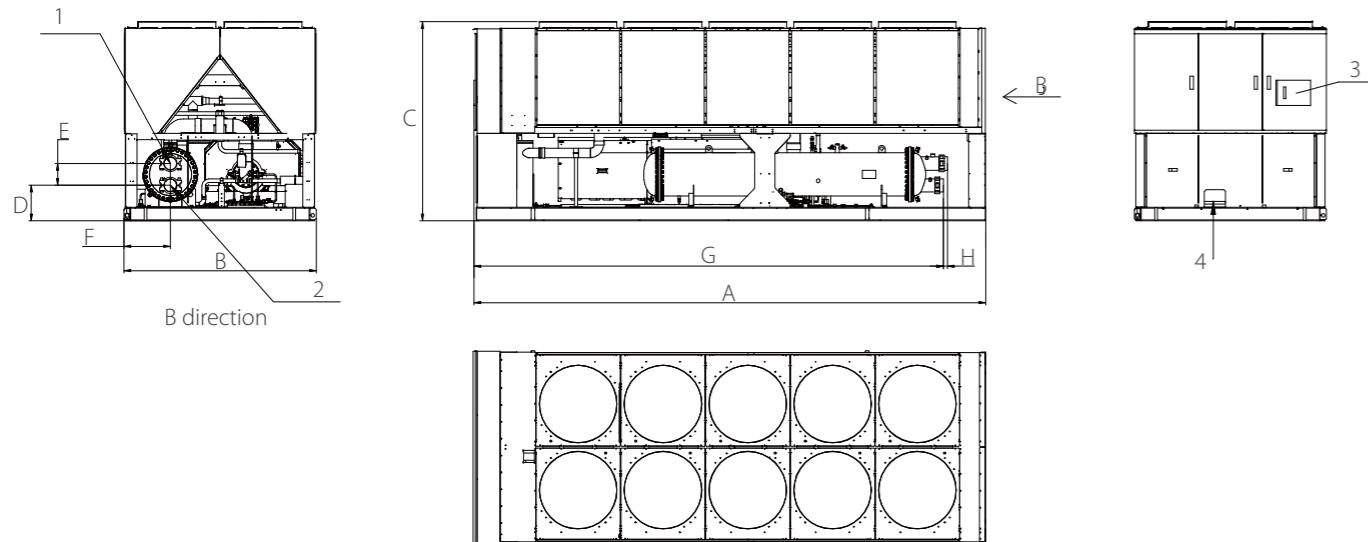

① Chilled water outlet ② Chilled water inlet ③ Control panel ④ Power incoming line

Dimensions (unit: mm)

Model	A	B	C	D	E	F	G	H
SCAG195H	6060	2300	2460	425	260	550	5560	50

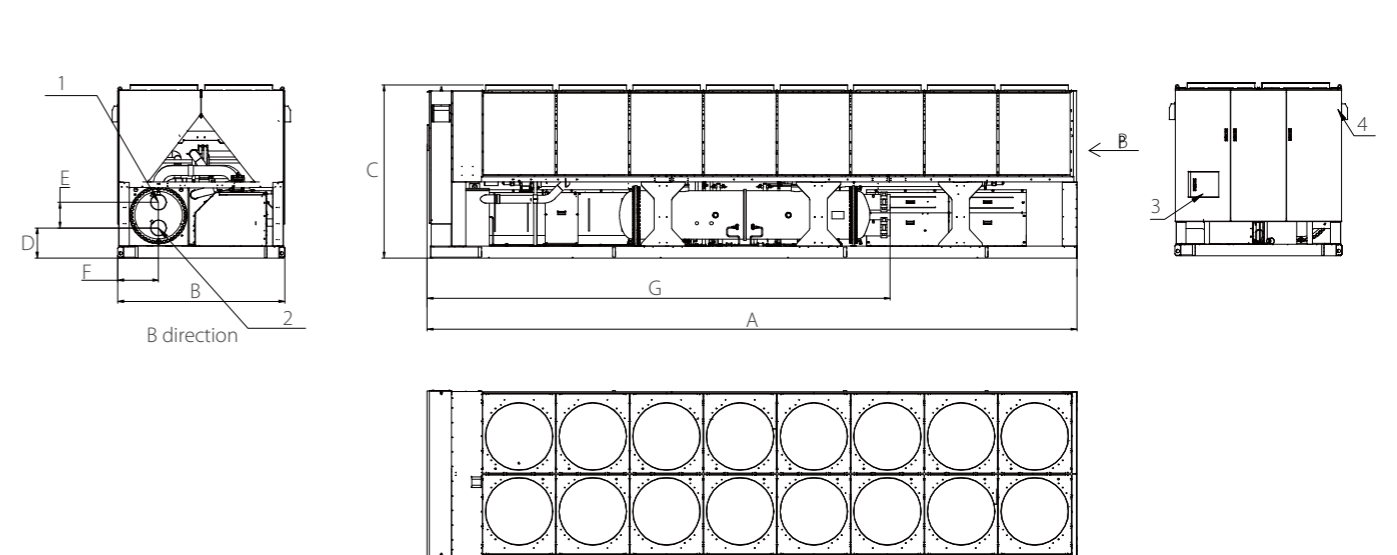

① Chilled water outlet ② Chilled water inlet ③ Control panel ④ Power incoming line

Dimensions (unit: mm)

Model	A	B	C	D	E	F	G
SCAG295H	8865	2300	2460	410	350	555	6320

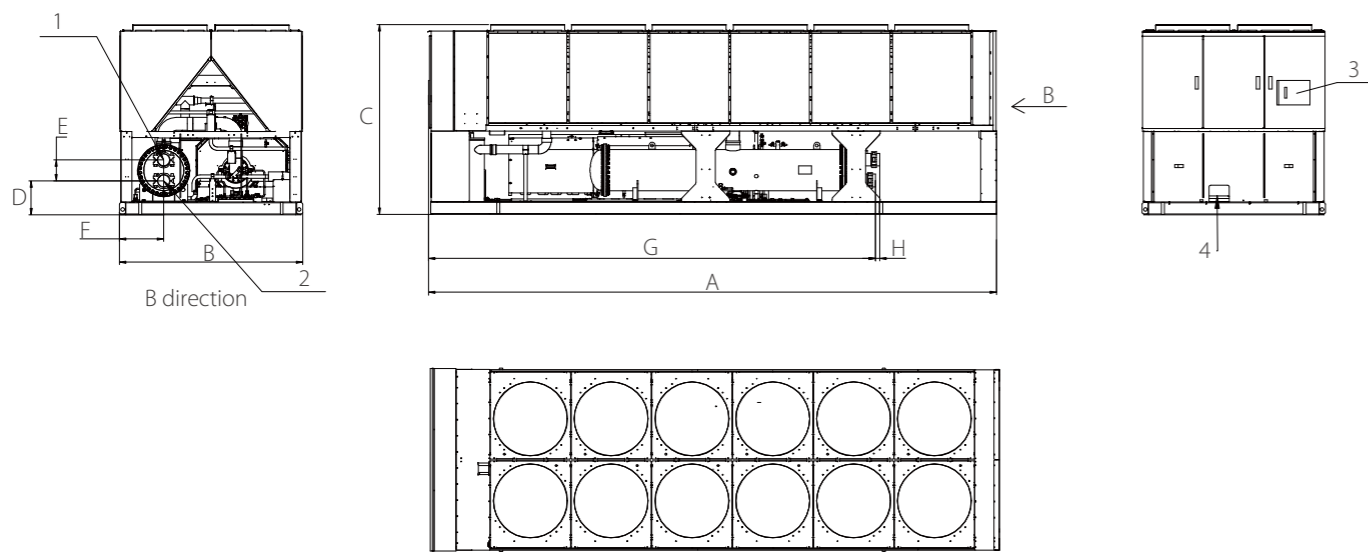

① Chilled water outlet ② Chilled water inlet ③ Control panel ④ Power incoming line

Dimensions (unit: mm)

Model	A	B	C	D	E	F	G	H
SCAG210H	7065	2300	2460	420	260	550	5560	50
SCAG245H	6835	2300	2460	425	300	570	6595	-

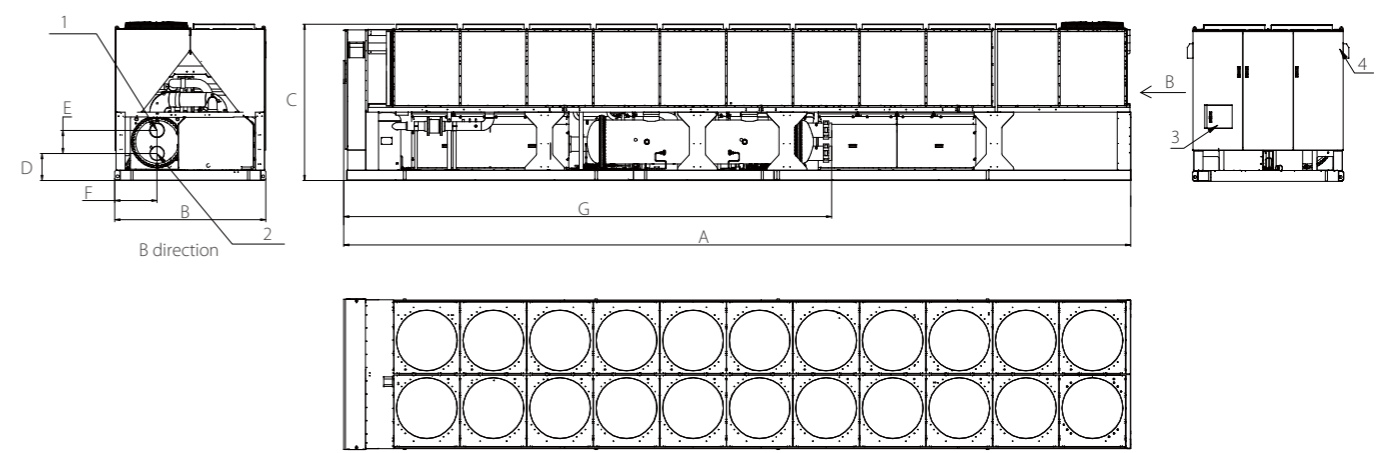

① Chilled water outlet ② Chilled water inlet ③ Control panel ④ Power incoming line

Dimensions (unit: mm)

Model	A	B	C	D	E	F	G
SCAG480H	11880	2300	2460	410	350	635	7370

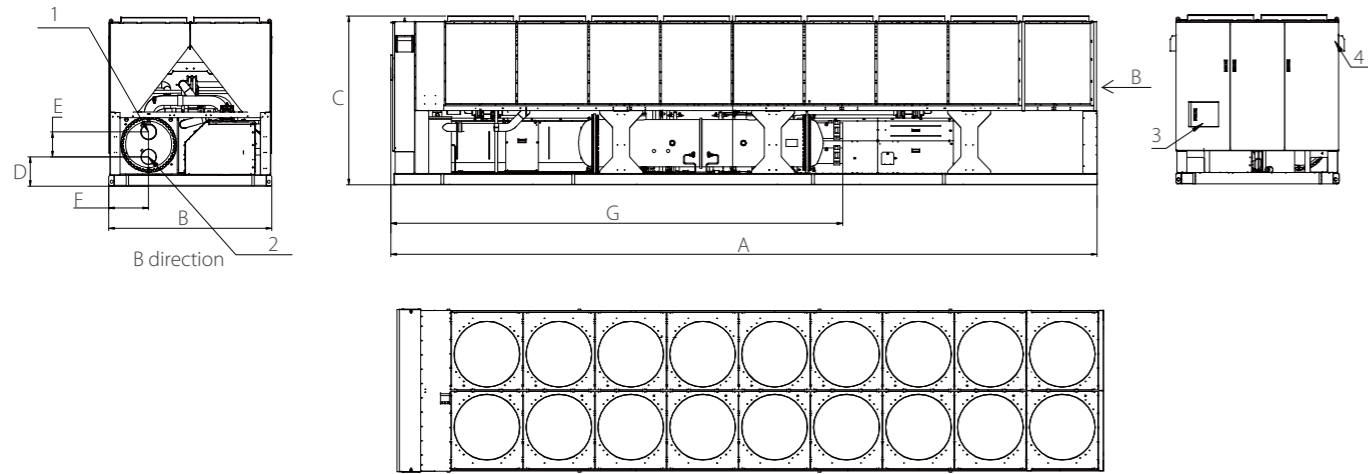

① Chilled water outlet ② Chilled water inlet ③ Control panel ④ Power incoming line

Dimensions (unit: mm)

Model	A	B	C	D	E	F	G
SCAG335H	9870	2300	2460	410	350	560	6320

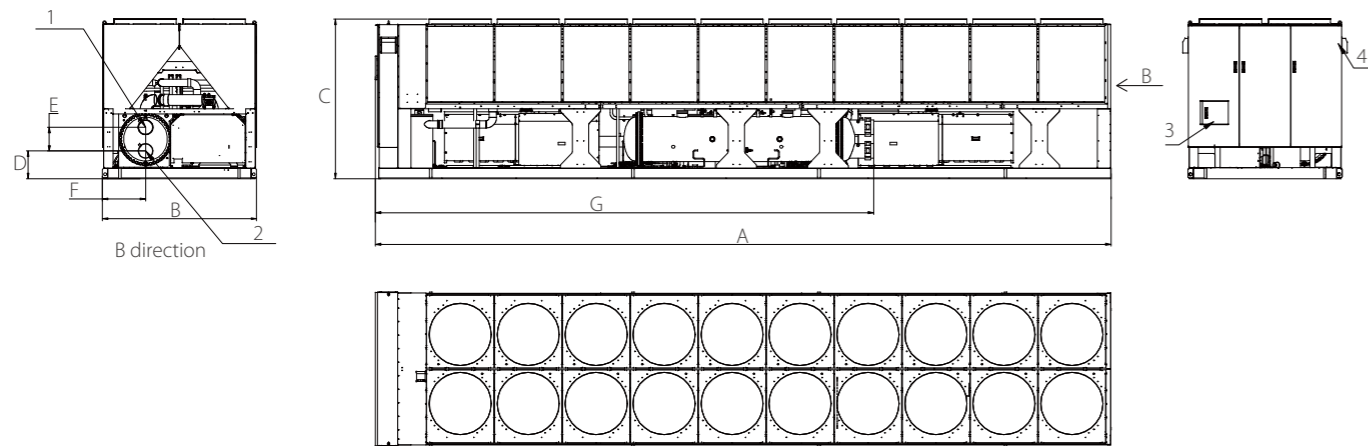

① Chilled water outlet ② Chilled water inlet ③ Control panel ④ Power incoming line

Dimensions (unit: mm)

Model	A	B	C	D	E	F	G
SCAG380H	10875	2300	2460	410	350	635	7370
SCAG420H							

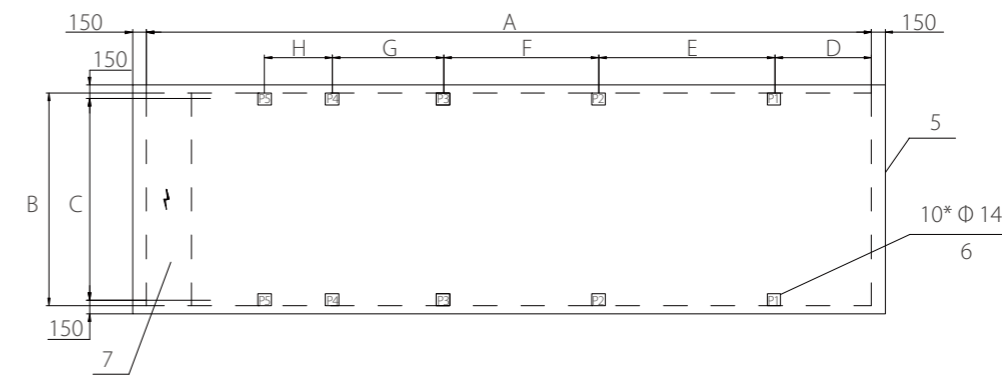

⑤ Installation foundation ⑥ Spring isolator installation hole ⑦ Electric control box

Models of spring isolators at all points

Model	P1	P2	P3	P4	P5
SCAG280H	MHD-850	MHD-850	MHD-850	MHD-850	MHD-850

Dimensions (unit: mm)

Model	A	B	C	D	E	F	G	H
SCAG280H	7840	2300	2180	1050	1895	1680	1250	1200

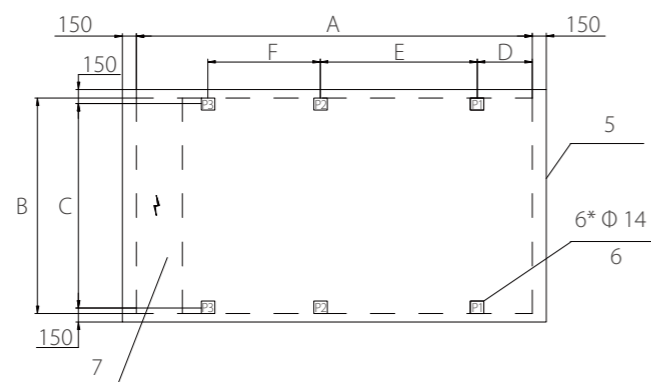

⑤ Installation foundation ⑥ Spring isolator installation hole ⑦ Electric control box

Models of spring isolators at all points

Model	P1	P2	P3
SCAG115H	MHD-850	MHD-850	MHD-850
SCAG135H	MHD-850	MHD-850	MHD-850
SCAG170H	MHD-1050	MHD-1050	MHD-1050

Dimensions (unit: mm)

Model	A	B	C	D	E	F
SCAG115H	4225	2300	2180	590	1670	1200
SCAG135H	4255	2300	2180	590	1670	1200
SCAG170H	5055	2300	2180	1165	1875	1250

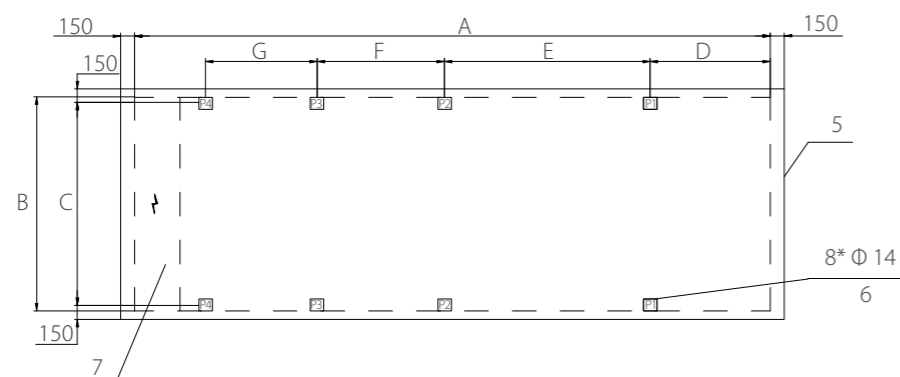

⑤ Installation foundation ⑥ Spring isolator installation hole ⑦ Electric control box

Models of spring isolators at all points

Model	P1	P2	P3	P4
SCAG195H	MHD-850	MHD-850	MHD-850	MHD-850
SCAG210H	MHD-850	MHD-850	MHD-850	MHD-850
SCAG245H	MHD-1050	MHD-1050	MHD-1050	MHD-1050

Dimensions (unit: mm)

Model	A	B	C	D	E	F	G
SCAG195H	6060	2300	2180	1250	1800	1050	1140
SCAG210H	7065	2300	2180	1744	2190	1050	1320
SCAG245H	6835	2300	2180	1290	2210	1370	1200

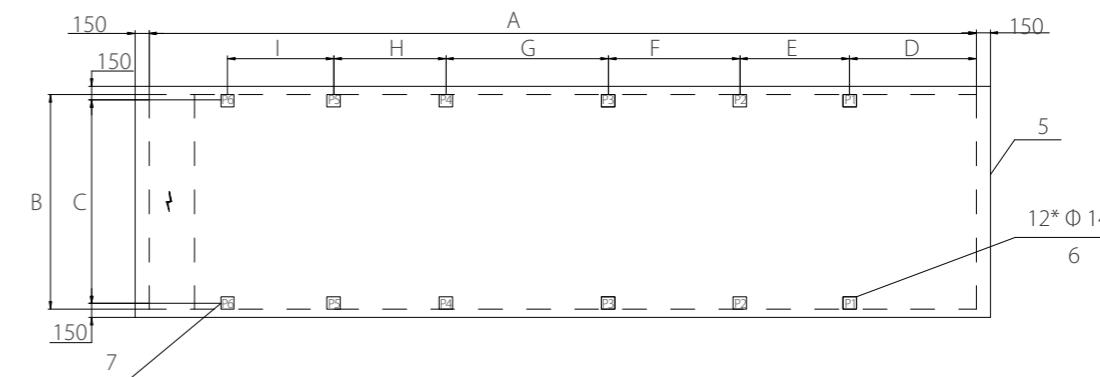

⑤ Installation foundation ⑥ Spring isolator installation hole ⑦ Electric control box

Models of spring isolators at all points

Model	P1	P2	P3	P4	P5	P6
SCAG295H	MHD-850	MHD-850	MHD-850	MHD-850	MHD-850	MHD-850
SCAG335H	MHD-1050	MHD-1050	MHD-1050	MHD-1050	MHD-1050	MHD-1050

Dimensions (unit: mm)

Model	A	B	C	D	E	F	G	H	I
SCAG295H	8865	2300	2180	1360	1175	1410	1740	1200	1140
SCAG335H	9870	2300	2180	1875	1440	1155	1970	1450	1165

Installation and Maintenance

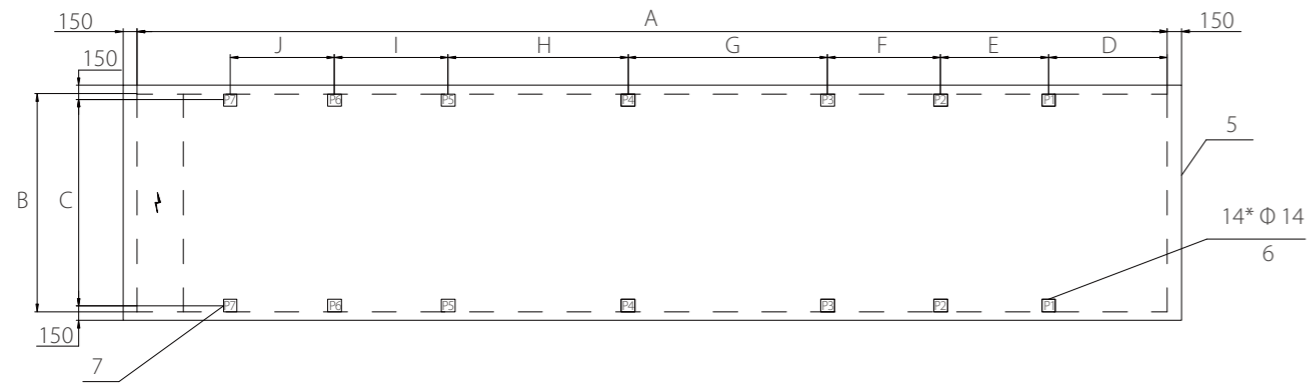

⑤ Installation foundation ⑥ Spring isolator installation hole ⑦ Electric control box

Models of spring isolators at all points

Model	P1	P2	P3	P4	P5	P6	P7
SCAG380H	MHD-850	MHD-850	MHD-850	MHD-850	MHD-850	MHD-850	MHD-850
SCAG420H	MHD-1050	MHD-1050	MHD-1050	MHD-1050	MHD-1050	MHD-1050	MHD-1050
SCAG480H	MHD-1050	MHD-1050	MHD-1050	MHD-1050	MHD-1050	MHD-1050	MHD-1050

Dimensions (unit: mm)

Model	A	B	C	D	E	F	G	H	I	J
SCAG380H	10875	2300	2180	1255	1140	1195	2105	1900	1200	1100
SCAG420H	10875	2300	2180	1255	1140	1195	2150	1900	1200	1100
SCAG480H	11880	2300	2180	1000	1900	1600	2200	2000	1200	1200

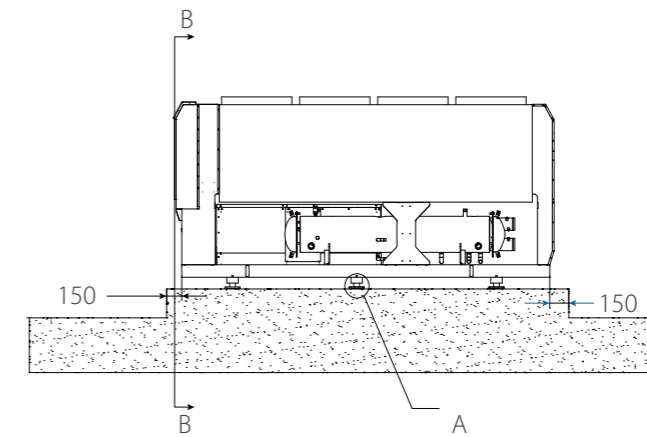

B-B Sectional View

Layout A

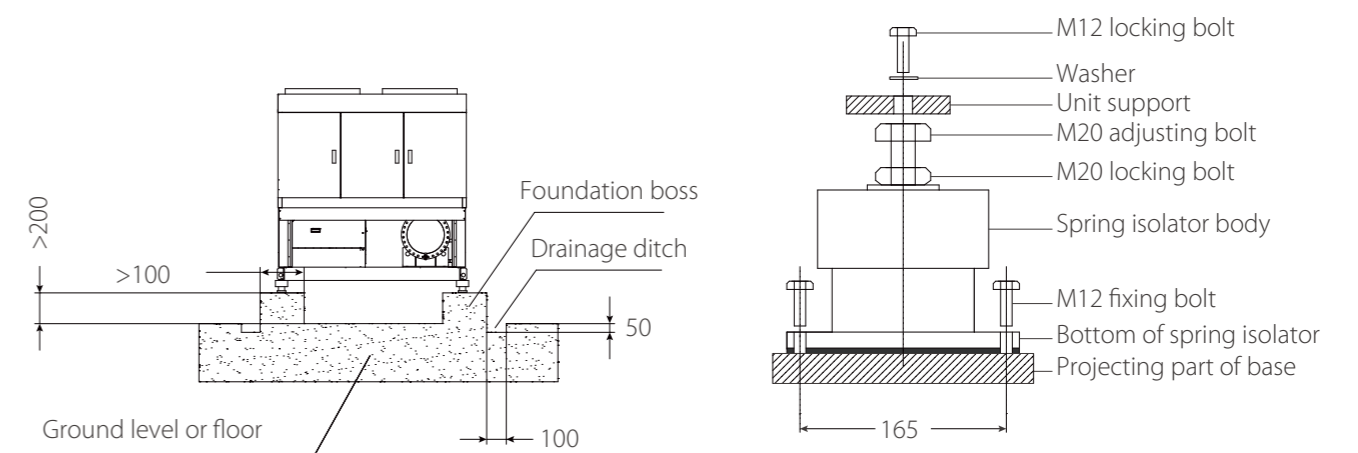

Notes:

1. The unit should be installed on the base due to vibration, and the base should be strong enough to bear the operating weight of the unit.
 2. When the concrete base is constructed, it is necessary to build drainage ditches around the base to facilitate drainage.
 3. When the unit is installed, a spring isolator is required. See the unit base diagram for the size and location of the spring isolator.
 4. The standard products do not come with ground bolts. Customers may buy and install bolts according to the situation on site. The ground bolts can be installed in the reserved holes, or expansion bolts can be used.
- *The distance is 165 mm when the optional spring isolator provided by Midea is used.

Installation of a Single Unit

Enough space should be left around the unit for operation, maintenance and prevention of return air short circuit. The unit must be installed in an unenclosed space to clean the tube cluster or change the tube of the evaporator, and the door opening or other suitable opening can also be used. Spring isolators must be selected and installed according to the unit foundation drawing.

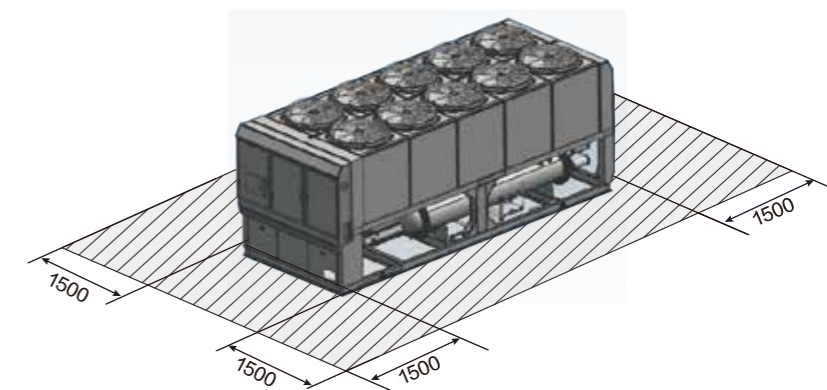

Two or More Units are Recommended to be Installed as Follows

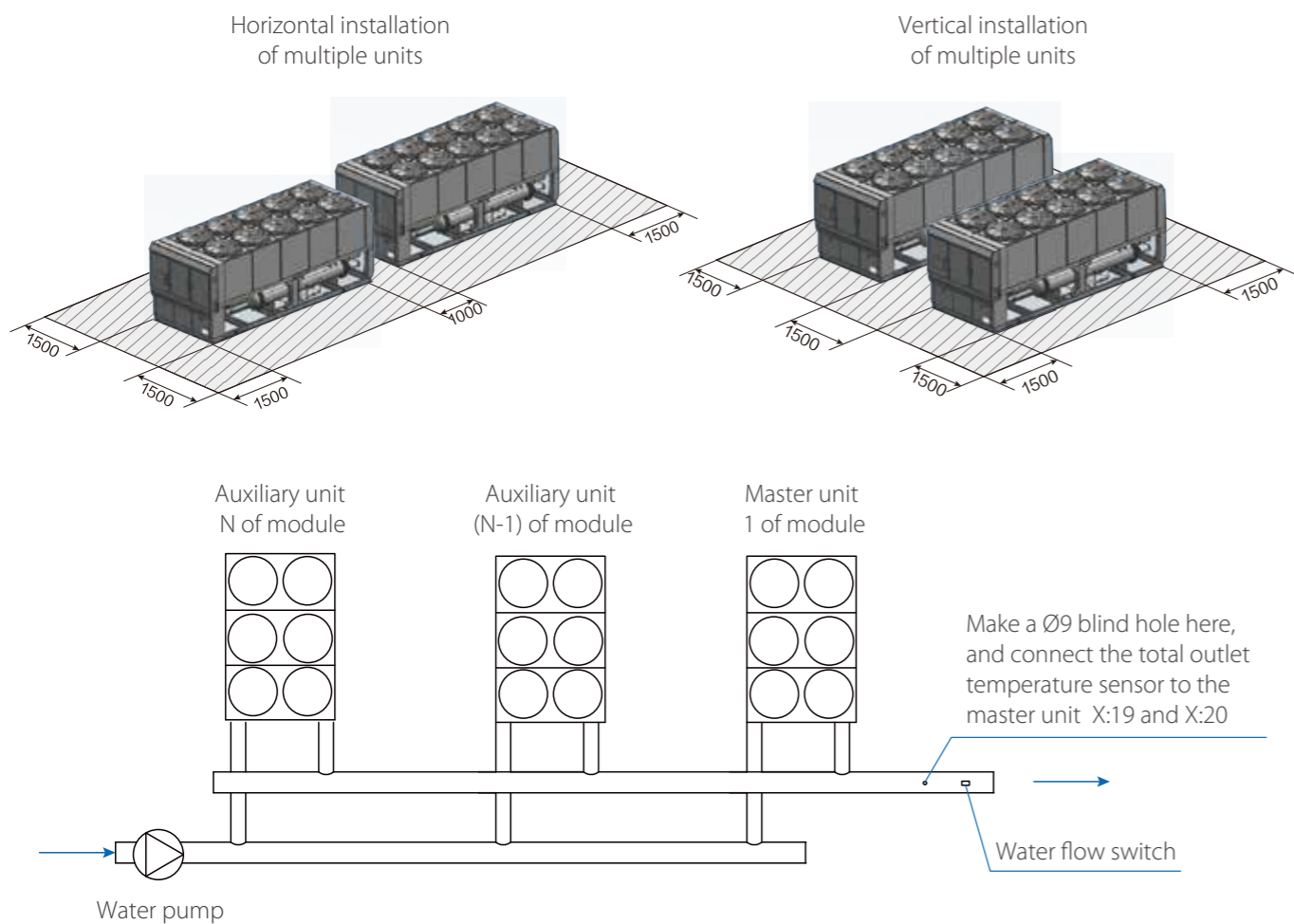

Special Installation Spaces

❖ The unit should be installed at a well-ventilated outdoor location. If it is installed close to a wall, the minimum installation distances are shown below:

❖ If there are facilities such as a canopy above the unit, the distances from the facilities to the unit top must meet the requirements of the following diagram (without enclosing wall around the unit).

❖ When the unit needs to be installed under the eaves, the distances must meet the requirements of the following diagram:

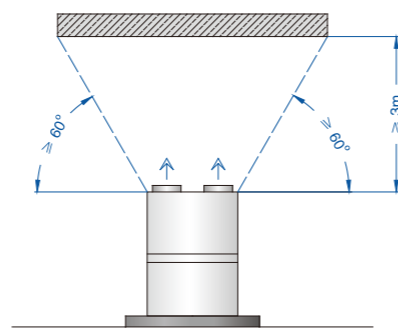
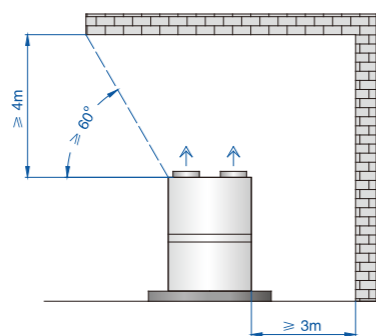
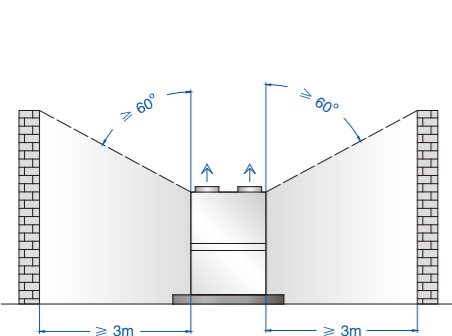

Electrical Wiring

Recommended water system

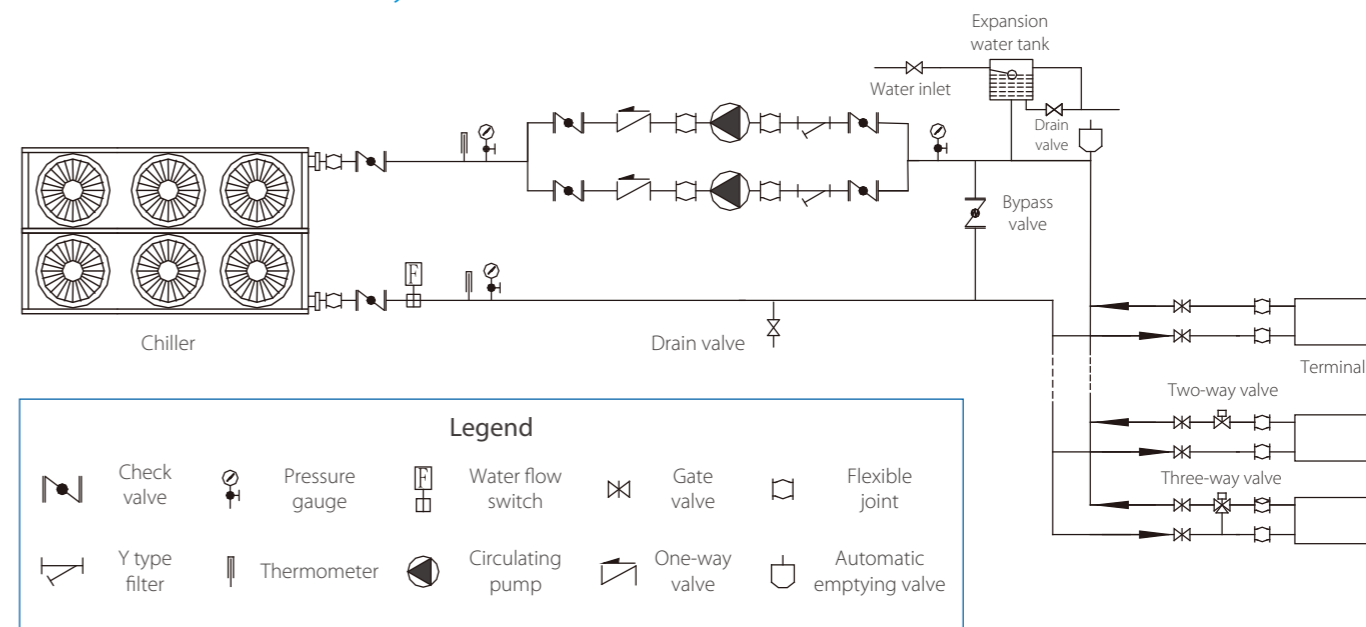

Field wiring diagram

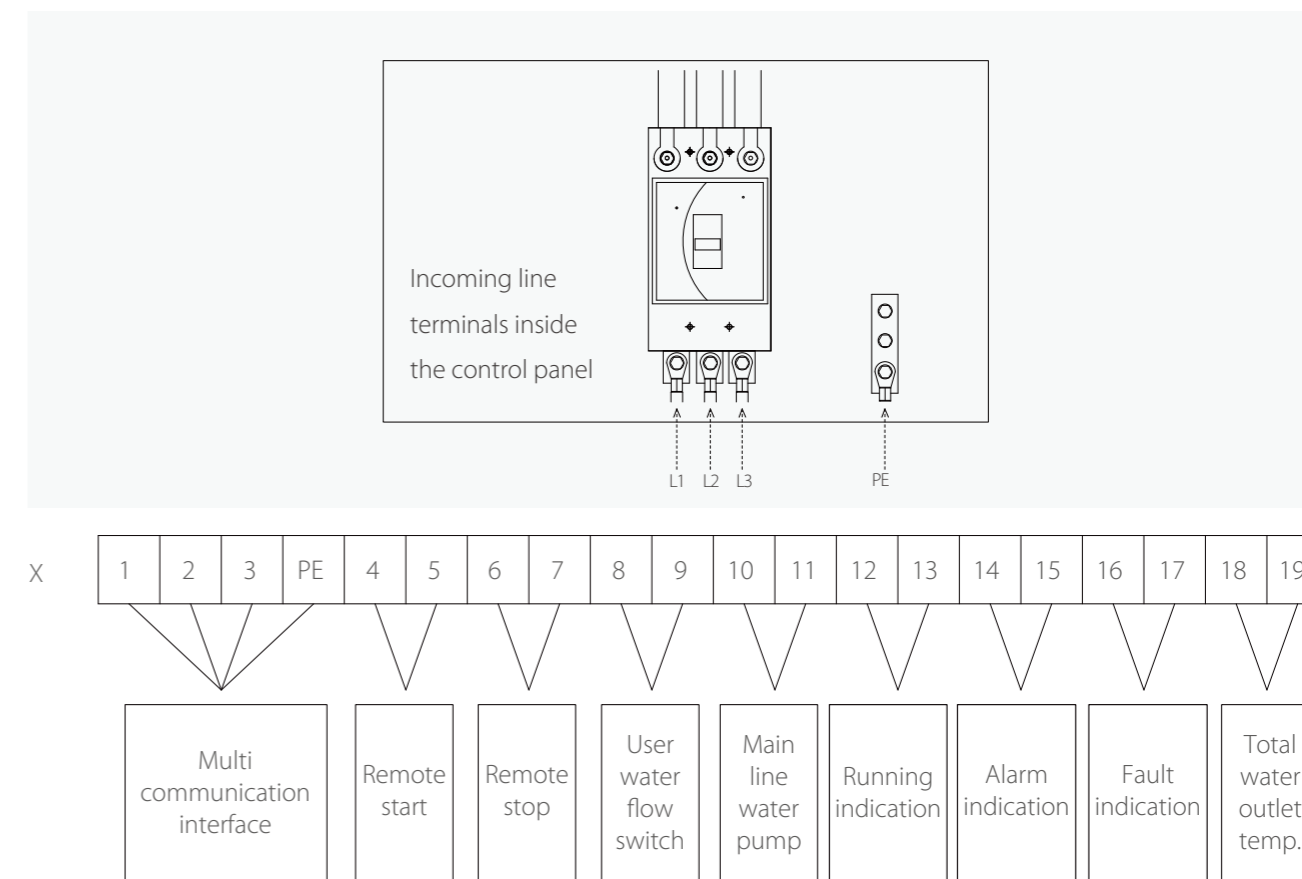

No.	signal	Signal type	Remarks
1	Multi communication interface	/	Communication shielded twisted pair, used when units are under multi-communication control
2	Remote start	Passive dry contact input	When the user needs remote control, it needs to be set to remote control state
3	Remote stop	Passive dry contact input	When the user needs remote control, it needs to be set to remote control state
4	User water flow switch	Passive dry contact input	Used to check the water flow rate of the unit
5	Main line water pump	Active AC220 dry contact output	When the unit pump is controlled by the unit
6	Running indication	Active AC220 dry contact output	External indication signal
7	Alarm indication	Active AC220 dry contact output	Monitoring is available when users need remote control
8	Fault indication	Active AC220 dry contact output	Monitoring is available when users need remote control
9	Total water outlet temp.	/	When the units are under multi-communication control mode, the master control panel is connected

External water pump

The water pump should be powered separately and the power supply cannot be led out of the electric control panel of the unit.

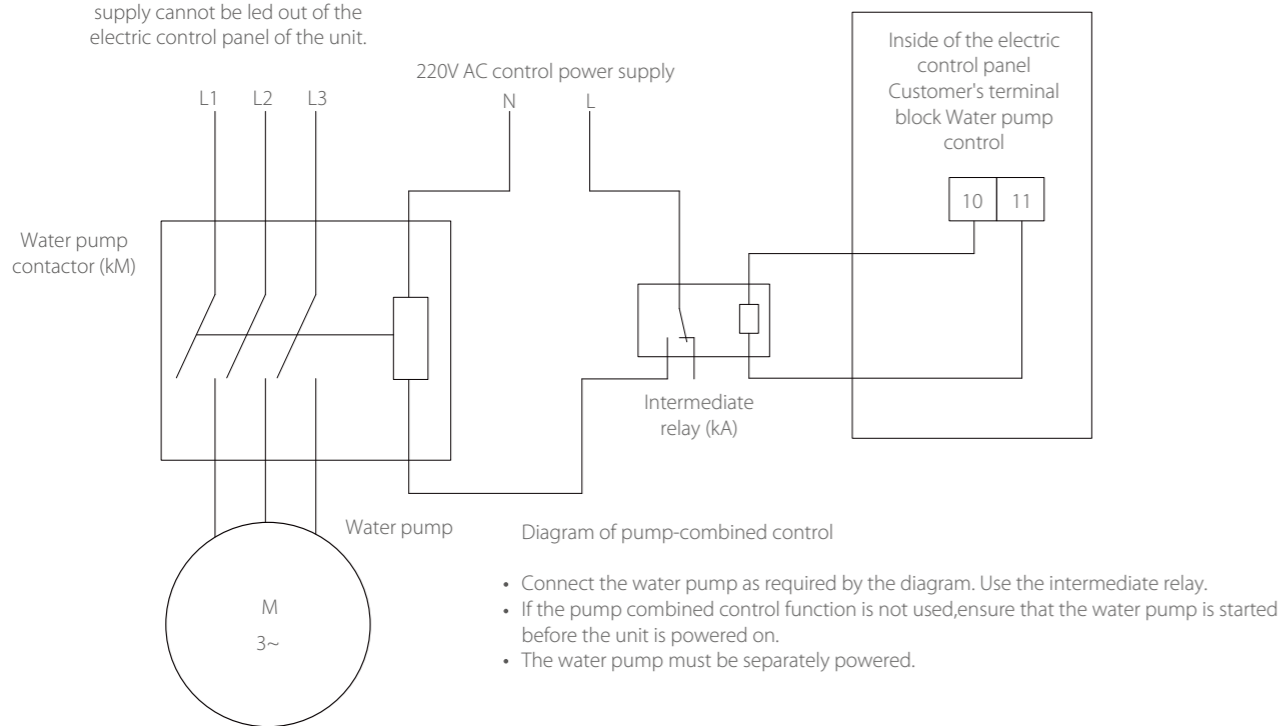

Wiring remarks:

1. The power supply line must be equipped with circuit breaker, the unit must be reliably grounded, and the grounding must be on the ground.
2. The selection of external wiring of the unit should meet the maximum operating current of the unit, and the selection of total power circuit breaker should meet the condition that misoperation will not be caused by starting current.
3. The wiring specifications of the main power supply are affected by practical aspects such as laying mode and length. Please refer to relevant information before configuration.
4. The user must do a good job of waterproof, dustproof and sealing at the inlet hole of the power line after wiring.
5. The cross-sectional area S of all signal lines is $0.75 \text{ mm}^2 \leq S \leq 1.5 \text{ mm}^2$.
6. For specific external wiring, please refer to the random electrical schematic diagram, and no further notice will be given if there is any change.

Options

Items	Standard	Optional
Power supply	380V-3Ph-50Hz	50Hz: 380V, 400V, 415V
Water side pressure	1.0MPa	1.6MPa, 2.0MPa
Heavy anti-corrosion treatment	×	√
Communication	Modbus-RTU (RS485 port)	BACnet IP, BACnet MS/TP(RJ-45 port)
Water pipe connection	Victaulic	Flange
Spring isolator	×	√
Water flow switch	√	√
Insulation	20mm	40mm
Compressor noise reduction box	×	√
Fin-coil heat exchanger protective net	×	√
Large temperature difference	×	8~10°C
Controller	MIC	PLC
Ice storage	×	√
All year round cooling	×	√(-20°C)
Vessel code	GB	ASME
Remote control panel	×	√
Midea Chiller Plant Control	×	√
Midea smart cloud platform	×	√
QuickView	×	√

Note: for other options, please contact with our engineers.

Intelligent Management

Midea Chiller Plant Control

Midea Chiller Plant Control is a group control system for commercial air conditioning that includes air conditioners, water pumps, cooling towers, terminals and related ancillary equipment (including valves, sensors etc.) as the underlying control objects. Based on a powerful control logic program and communication network, it establishes a 3-layer control framework that integrates the equipment, control and management layers. Midea Chiller Plant Control contains a unique operation module from Midea that is designed to save energy, so in addition to automated stable operations for the various devices, this product also improves and optimizes user management capabilities, reduces labour costs, boosts operational efficiency and lowers the overall energy consumption for commercial air conditioning.

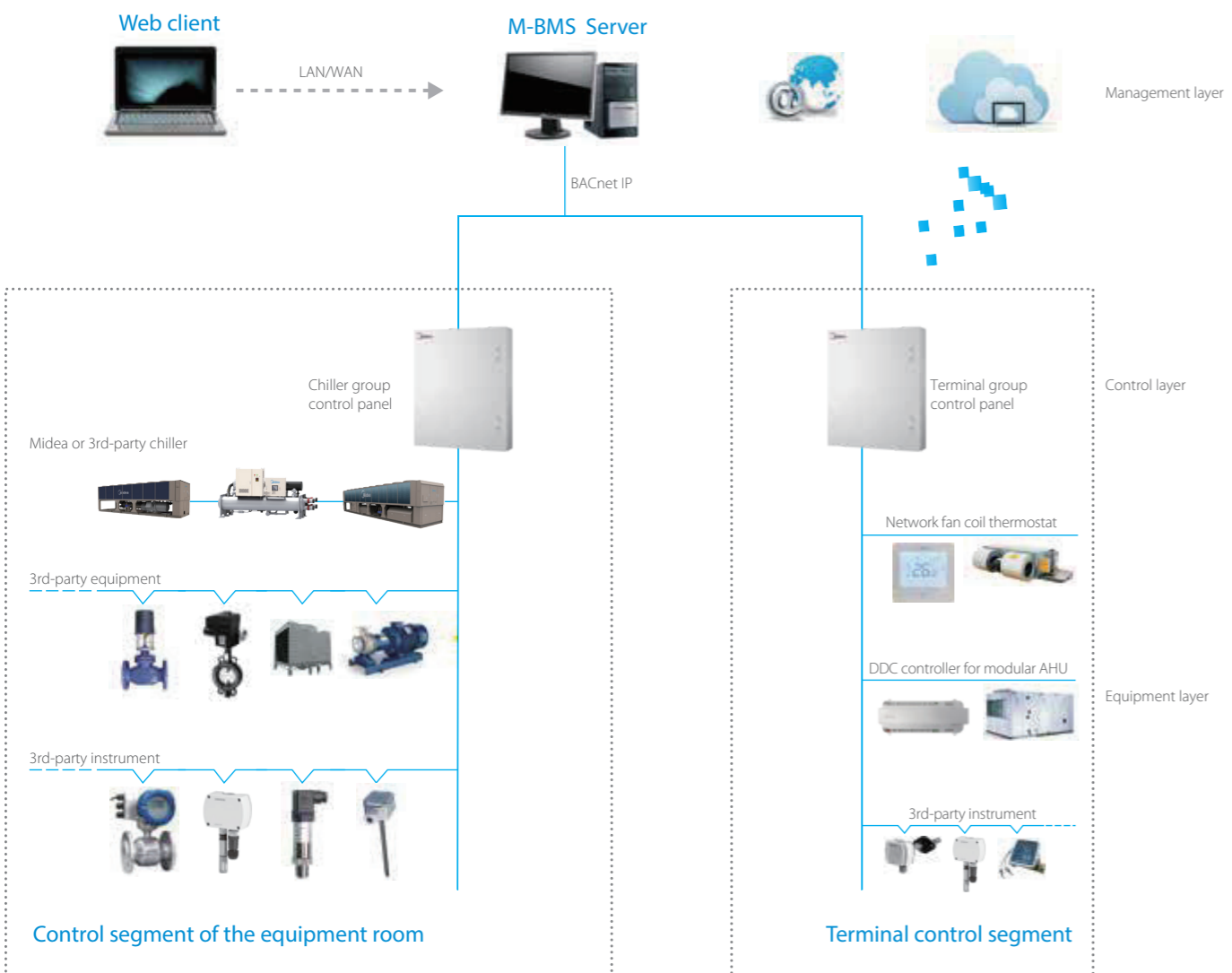

Midea Smart Cloud platform



Midea has built a flawless internet-based remote monitoring system, which provides customers with outstanding cloud service via advanced cloud service technologies and the internet. Customers can connect Midea air conditioner to the global remote monitoring system through Midea's IMU smart data acquisition terminal, so that professionals can help the customer to implement remote fault diagnosis, analysis and receive early warning alarms for failures, ensuring the equipment's optimal operation. Customers authorized by Midea can use a Web browser to view the real-time monitoring data of the air conditioning system.

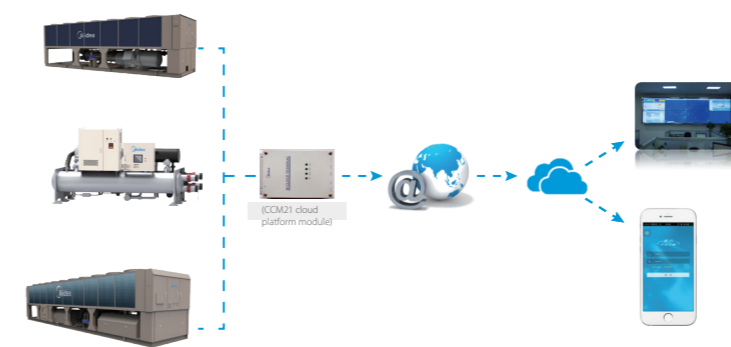

- 1 "Midea Smart Cloud" remote Internet monitoring service
- 2 Cloud data storage
- 3 Working condition data analysis
- 4 Quick fault diagnosis
- 5 Viewing monitoring data through the Web browser

QuickView

Midea's QuickView smart software control system is a type of smart software specially developed by Midea. It features high real-time efficiency, stability, reliability, a high degree of visualization and strong scalability. It can implement a wide variety of scenarios such as real-time data monitoring of units, unit equipment management, remote control, curve display, data storage, alarm query, fault diagnosis, uploading data to the cloud and external data analysis, greatly improving the unit's operation management efficiency and reducing the human input and operation and maintenance costs.

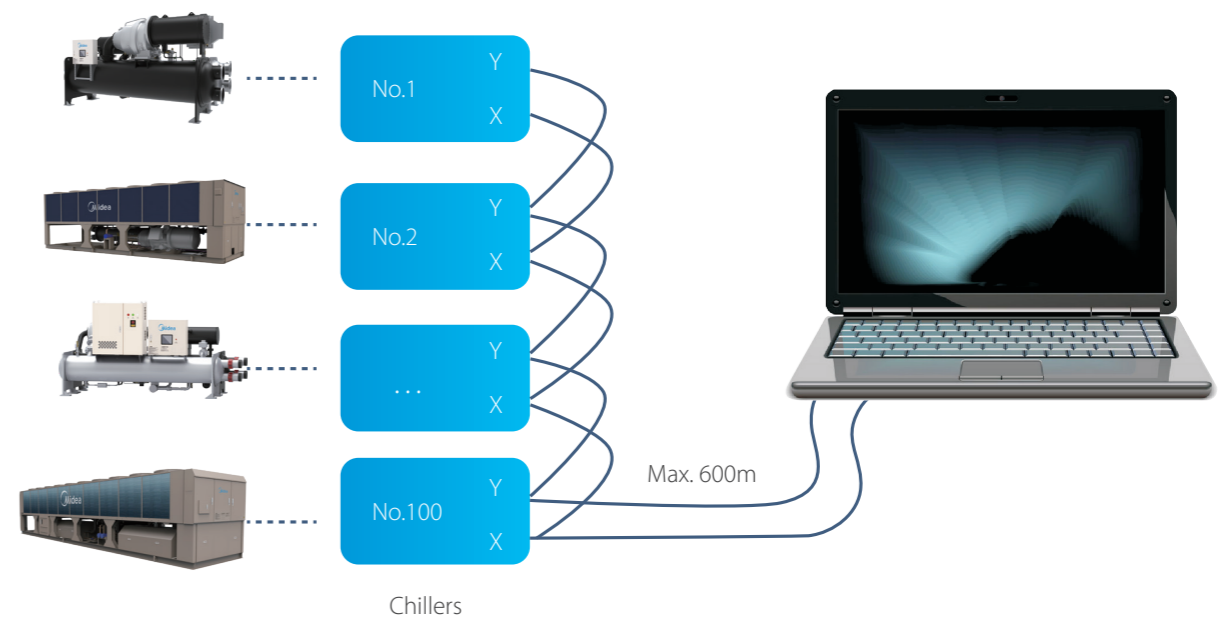



Mozambique Capital Airport

- Country: Mozambique
- City: Maputo
- Total Capacity: 4,000 RT
- Outdoor Unit: Air cooled screw chiller & DC Inverter VRF
- Indoor Unit: FCU & AHU
- Completion Year: 2012



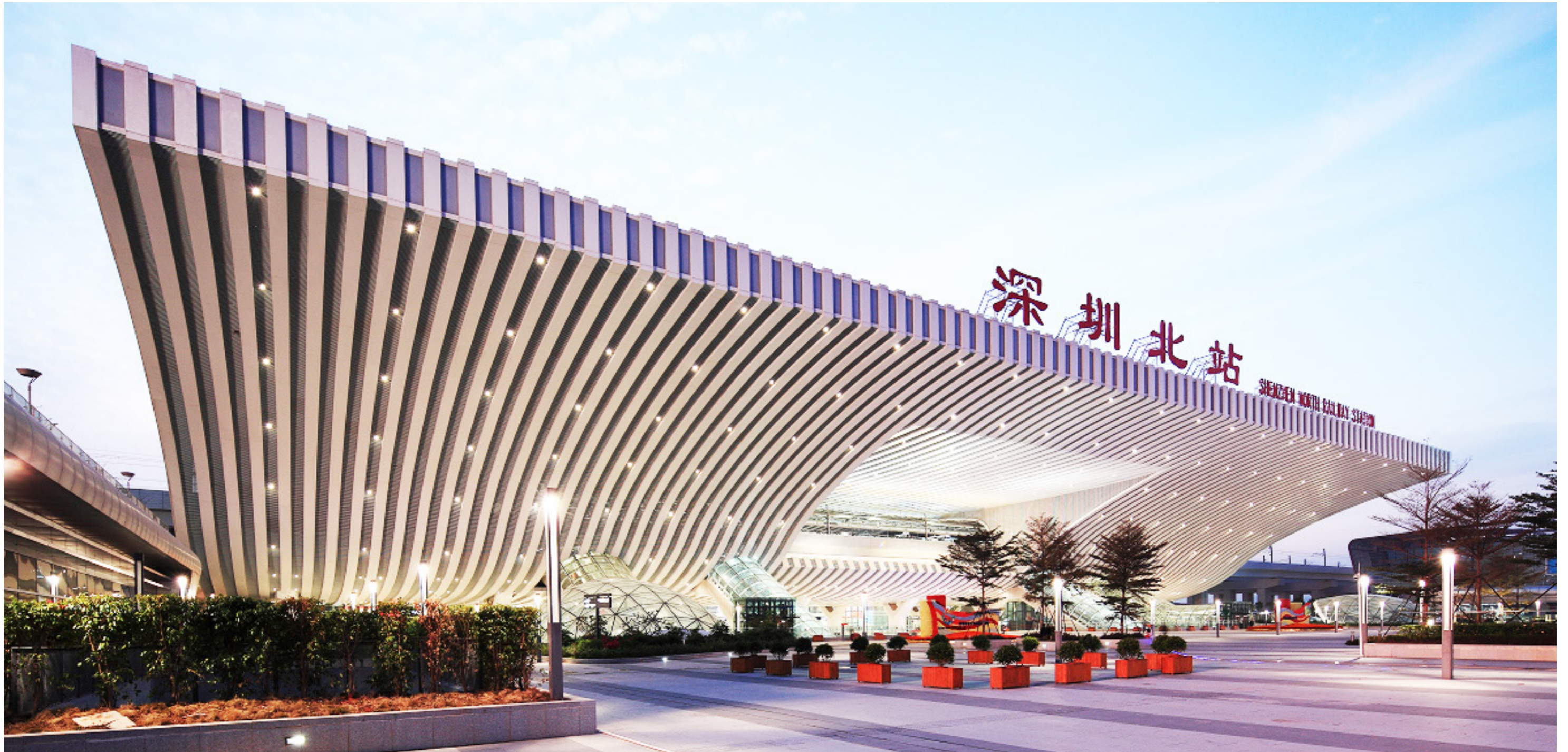

Shenzhen North Railway Station

Country:	China
City:	Shenzhen
Total Capacity:	2,842 RT
Outdoor Unit:	Air cooled screw chiller & DC Inverter VRF
Indoor Unit:	MAHU & AHU & FCU
Completion Year:	2012





Sheraton Bandara Resort Hotel (Five Star)

Country:	Indonesia
City:	Jakarta
Total Capacity:	1,050 RT
Outdoor Unit:	Air cooled screw chiller
Indoor Unit:	FCU
Completion Year:	2011



Hub Power Station

Country:	Pakistan
City:	Balochistan
Outdoor Units:	Tropical air cooled screw chiller
Total Capacity:	1,024 RT



Renaissance Hotel (Five Star)

Country:	Thailand
City:	Pattaya
Total Capacity:	512 RT
Outdoor Units:	Air cooled screw chiller
Indoor Units:	AHU
Completion Year:	2017



Sarab Community Market

Country: UAE
 City: Abu Dhabi
 Outdoor Units: Air cooled screw chiller
 Indoor Units: AHU
 Total Capacity: 1,137 RT



Indoor Stadium Huamark

Country: Thailand
 City: Bangkok
 Outdoor Units: Air cooled screw chiller
 Indoor Units: AHU
 Total Capacity: 8,800 kW



AL WAQF SHOPPING DISTRICT

Country: UAE
 Total Capacity: 1,240 RT
 Outdoor Units: Inverter air cooled screw chiller (T3)