

2C202405



Water Cooled Scroll Chiller (Heat Pump)



Midea Building Technologies Division
Midea Group

Add.: Midea Headquarters Building, 6 Midea Avenue, Shunde, Foshan, Guangdong, China
Postal code: 528311

mbt.midea.com/global www.midea-group.com ics.midea.com

Midea reserves the right to change the specifications of the product, and to withdraw or replace products without prior notification or public announcement. Midea is constantly developing and improving its products.



2024

MAKE A BEAUTIFUL TOMORROW

Midea MBT

Midea MBT(Midea Building Technologies) is a key division of the Midea Group, a leading provider of comprehensive solutions of intelligent building, involving energy sources, elevators, control systems, and heating, ventilation & air conditioning. Midea MBT has continued with the tradition of innovation upon which it was founded and emerged as a global leader in the HVAC and building management industry. A strong drive for advancement has resulted in an extensive R&D department that has placed Midea MBT at the forefront of a competitive edge. Through these independent projects and joint-cooperation with other global enterprises, Midea has supplied thousands of innovative solutions to customers worldwide.

Several production bases are situated on Shunde, Chongqing, Hefei, and Italy.

MBT Shunde: 38 product lines focusing on VRF, Split Products, Heat Pump Water Heaters and AHU/FCU.

MBT Chongqing: 14 product lines focusing on Water Cooled Centrifugal/Screw/Scroll Chillers, Air Cooled Screw/Scroll Chillers and AHU/FCU.

MBT Hefei: 11 product lines focusing on VRF, Chillers and Heat Pump Water Heaters.

Clivet S.p.A: 50,000m2 workshop in Feltre and Verona, covering products such as ELFO system, hydronic, WHLP, packaged, split and close control and so on.



MBT Learning Academy



Objective

MBT Learning Academy aims to provide training to the sales personnel as well as technical personnel in order to increase the utilization for your MBT equipment. Once you have purchased equipment from MBT, taking care of the equipment is topmost priority. MBT Learning Academy offers training courses to learn firsthand from the manufacturer what it takes to get the best out of your MBT product. The goal of MBT Learning Academy is to provide product specific training, safe work procedures and expertise in carrying out the installation and maintenance of MBT products as well as teaching the main selling points in order to help the sales people sell the MBT products with ease.

Training Centers

Our world class training centers provide knowledge and skills necessary to efficiently deploy MBT technologies. The training centers include dedicated laboratories to provide hands-on experiences with various systems, components and controls to refresh and enhance the skills of your sales, design and installation and service teams. Right now we operate our trainings from the below two locations:

1. MBT Training Center

Address: MBT Training Center, 2nd Floor, Building 6, Midea Global Innovation Center, Beijiao, Shunde, Foshan, China Pin-528311

The Midea MBT Training Center is situated 70 kilometers from Baiyun Guangzhou International Airport.

Products: VRF, M thermal

2. Chongqing Midea Training Center

Address: No. 15, Qiangwei Road, Nan'an District, Chongqing, China

Chongqing Midea Training Center is 35 kilometers from Chongqing International Airport.

Products: Centrifugal Chiller, Screw/Scroll Chiller and Terminals



VRF training



M thermal training



Chiller training

Global Technical Trainings

The training courses by MBT Learning Academy are divided into the following two categories with different targeted audiences for each.

Design and Application Trainings: The design and application trainings for various products are basically for the sales personnel selling MBT products in order to give them basic understanding about the main features. The trainings are conducted on a global level inviting sales engineers, technical engineers, consultants and project designers from different parts of the world.

After Sales- Service Trainings: These trainings are dedicated for the After Sales/ Service personnel in order for them to better carry out the installation, commissioning and maintenance of MBT products. Technical person and engineers from different parts of the world are invited to take part in these trainings.

Online Trainings: The trainings to the Global customers can also be done online with the help of Team and Midea Meeting software. This way, the customers do not need to be physically present for the training. Amid the COVID-19 pandemic, MBT Learning Academy has conducted a lot of online trainings. The training videos are available on the ICS system and can be downloaded by using QR codes.

Products: VRF, M thermal, Chillers and Terminals

Highly Skilled Trainers: The trainers for various courses by MBT Learning Academy are expert people with vast experiences in their field. Most of them have a deep insight about the global HVAC market and help the attendees to better understand the MBT products.

Training Certificates:

The attendees for Global trainings are provided a training certificate highlighting the courses discussed in the training, signed by Mr. Henry Cheng, General Manager of MBT Overseas Sales Company.

Registration:

You can contact your respective Midea contact point to provide you with the complete schedule about the global technical trainings as well as how to register for these trainings.

For further enquiries about the Global Trainings conducted by MBT Learning Academy, please send email at the following email address: peeyush@midea.com



Chiller After Sales Courses



Chiller Introduction Courses

Midea Global Spare Parts Center

The global spare parts center provides high quality and fast spare parts supply. Midea online system (<https://ics.midea.com>) can query and purchase spare parts with one click, further shortening the supply time of spare parts.

The “**2** (HQ Spare parts center) + **10** (Regional Spare parts center) + **N** (Country Spare parts inventory)” Spare Parts Layout can ensure the timely supply of global after-sales spare parts.



International Service Management (ICS)

ICS is a platform for customers to seek professional technical support. Through ICS, you can inquire about product information, documentation, spare parts and troubleshooting, ask technical questions, submit complaints, and order spare parts.

<https://ics.midea.com>



My order

Inquire about spare parts from an exploded view and place orders for spare parts directly in ICS.

Document inquiry and download

View or download product technical documentation online, such as catalogs, images, training PPTs, etc.

Technical inquiry & FAQ

Ask technical questions online and receive a prompt response from our technicians. Or find a quick solution in the FAQ.

Troubleshooting

Query the error code and solution by SN, model name, error code or product type.

Complain

Submit product quality complaints online, and our after-sales engineers will respond promptly.

Mobile Intelligence Service App (MISA)

MISA is the mobile terminal of ICS, with the same functions as ICS. The mobile service improves the response time and convenience of technical support.

<https://link.midea.com>



FAQ



Complain



Technical Enquiry



Trouble shooting

Download



Scan to download the mobile app

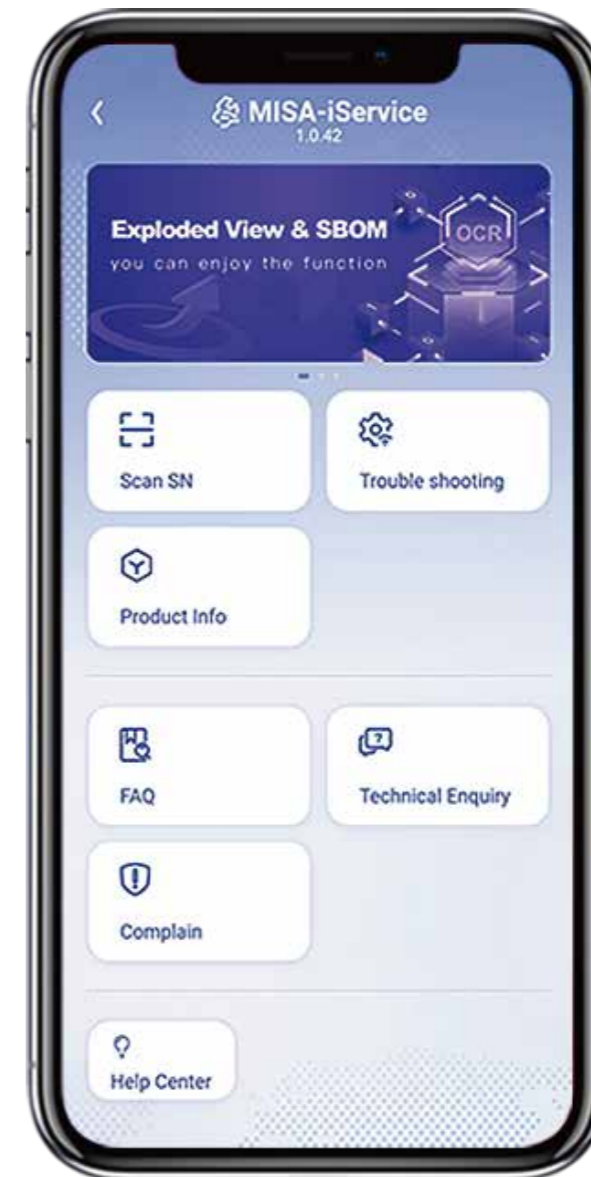

Search product manuals



Spare parts list

Feedback



Thank you for your attention and feedback



Contents

Overview	10
Features	11
Specifications	17
Installation	22

Overview

Midea water cooled scroll chillers (heat pumps) are designed and developed based on more than 50 years' experience in chiller design. With an input power of 1 kW, they can output a cooling or heating capacity of over 5 kW at an operating cost much lower than that of traditional air conditioning units thanks to advanced technologies and more energy-efficient air-conditioning solutions. The unit features high energy efficiency, intelligent control, outstanding stability and reliability. It is also convenient to install, provides option for both cooling and heating as well as is eco-friendly.

The product can be applied in a variety of small and medium-sized centralized cooling/heating scenarios, for projects like small and medium-sized hotels, clubs, small and medium-sized factories, renovation projects and structures without indoor equipment rooms.



Nomenclature

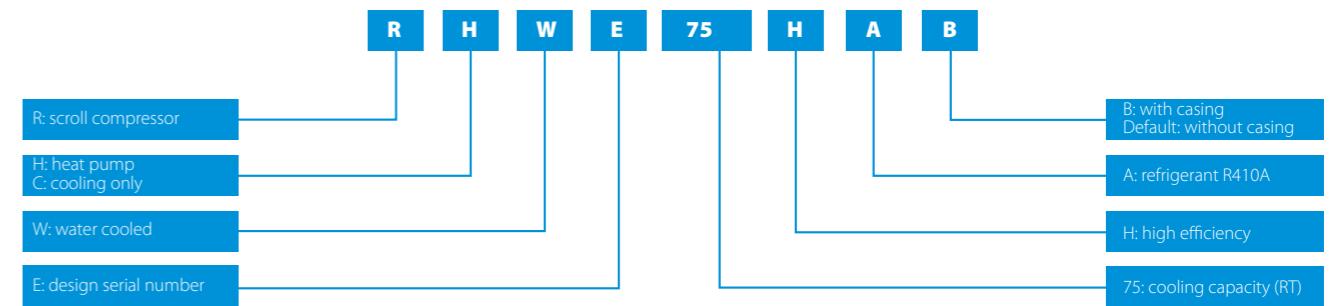

Features

Energy saving

❖ Hermetic, more powerful scroll compressor

The new flexible scroll compressor's scroll plate features a floating sealing, which minimizes wear and leakage.

High efficiency

The unit adopts a contact-free and wear-free scroll design to reduce internal friction of the compressor and improve efficiency.

Low maintenance cost

The unit adopts eco-friendly lead-free polymer bearings to ensure stable operation and reduce maintenance costs.

Low noise and vibration

A soundproof enclosure is installed at the bottom of the compressor to reduce noise by 10%. The vibration is reduced accordingly.

Note: The actual compressor may vary.

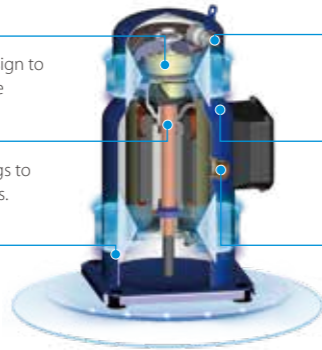

Stable performance

The compressor outlet is equipped with a check valve to avoid backflow of refrigerant, thus ensuring high reliability.

Maintenance and repair free

Thanks to the fully enclosed design, the unit does not require maintenance or repairs.

Long life

The suction cooling motor is used to improve the efficiency and prolong the service life of the compressor.

❖ High efficiency shell-and-tube heat exchanger on two sides

A DX type evaporator is used. The refrigerant flows into the heat exchange tube to facilitate oil return. The inner-threaded heat exchange tube is used to increase the effective heat exchange area. The turbulent water flow design improves heat exchange efficiency.

The condenser adopts a large-diameter heat exchange tube. It features a high water quality tolerance, internal cleaning and maintenance is simple. Its unique super-cooling design provides improved heat exchanger performance.

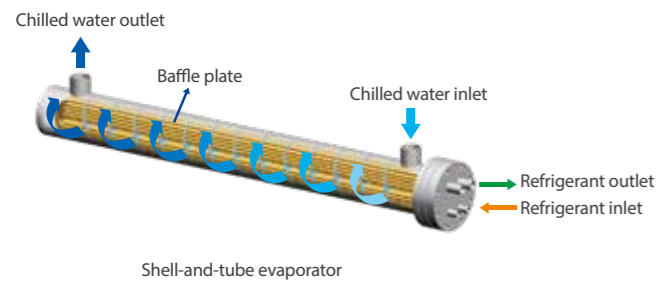

❖ Highly Precise EXV, more accurate temperature control

The unit adopts an electronic expansion valve as the fine control component of the refrigerant. The electronic expansion valve takes only a few seconds to switch from fully closed to fully open. The reaction and action speed is fast and there is no static superheating. It can achieve a light-load start, reduce heat loss during shutdown, improve the stability and reliability of the unit as well as reduce the unit's operation costs.



The electronic expansion valve eliminates hysteresis in refrigerant control and ensures that the compressor always operates in the optimal mode.

Traditional thermal expansion valves have the following disadvantages: hysteresis in refrigerant control, low unit stability and high operation expense.

Stable and reliable

❖ Two systems operate independently for enhanced system reliability

The failure of one system of a unit does not affect the operation of the whole unit. The failure of a system does not affect the operation of the entire system when multiple units are used. No backup unit is needed, saving money for the user. The air conditioner can continue operating before service person arrives, making operation easier for users in remote areas.

Uninterrupted operating in case of single system failure

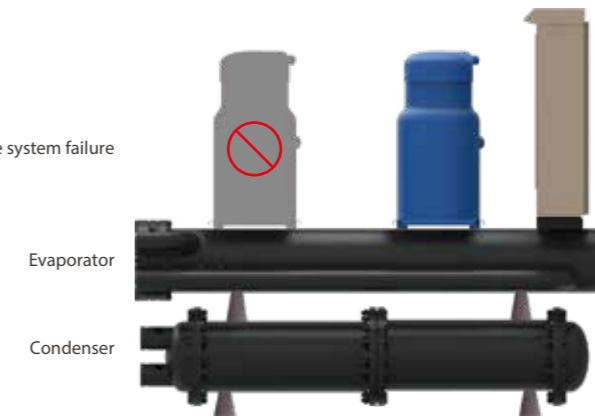

❖ Automatic balancing of the running time for each system to extend the life of the unit

This unit is equipped with running time balancing function, so that when one unit is used, the running time of the system in the unit is automatically balanced. When multiple units are used, the running time of each system is automatically balanced, reducing the failure rate and extending the life of the unit.

❖ Multiple protection functions, ensuring safe operation of the system

The module unit progressive start feature reduces the shock on the grid caused by the starting current. The unit is equipped with a high-pressure switch, overload protection device, power supply phase protection device and an operation control device which automatically alarms in the event of a failure.



Compressor high/low-pressure protection



Power supply phase reverse/loss protection



Anti-freezing protection in running mode



Over-/under-voltage protection



Frequent start protection



Compressor over-current protection



Compressor discharge temperature protection



Unit overheating protection



Low water flow rate protection



Sensor fault protection

Eco-friendly and silent operation

R410A, as a new eco-friendly and efficient refrigerant, does not contain Chlorine that depletes the ozone layer and its Ozone Depletion Potential (ODP) value is 0. Thanks to the hermetic compressor and casing, the noise of the unit is as low as 64 dB(A).

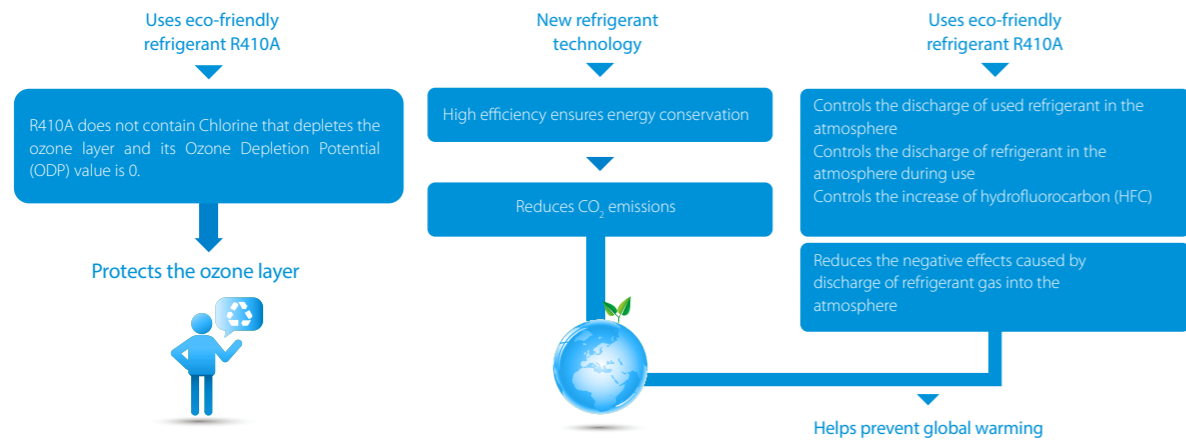

Easy-to-install design requiring no equipment room

❖ Can be moved into a freight elevator

The unit's compact body allows it to be moved into an old equipment room and freight elevator. The unit can be moved easily into the basement without dismantling the existing building structure.



Note: To be evaluated based on the actual dimensions of the unit and freight elevator.

❖ Can be handled by a forklift

Thanks to the unique base design, the whole series of units can be handled by a manual forklift, without professional lifting equipment, thus cutting installation costs.

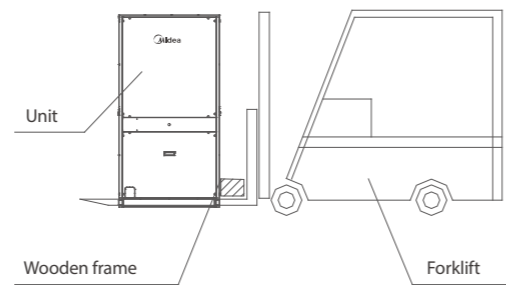

Forklift Handling Diagram



❖ Flexible installation site

Because of its external casing, the unit does not need a dedicated equipment room. It can be installed indoors, outdoors or on the rooftops. Units can be installed without spacing, thus saving installation space.

❖ Easy to expand

In the peak hour of users and summers, the cooling capacity of the existing units cannot meet the demand. The cooling capacity of Midea's water cooled scroll units can be expanded flexibly, which greatly improves the availability and stability of the air conditioning system.

Multiple system application modes

Since the low-temperature surface heat source of the earth is not affected by atmospheric temperature, it remains relatively stable throughout the year. In winter, water (ground) source heat pump units can obtain heat from shallow soil and surface water energy to produce hot water for heating and other purposes; in summer, water (ground) source heat pump units can discharge the indoor heat to the shallow soil and surface water to achieve cooling.

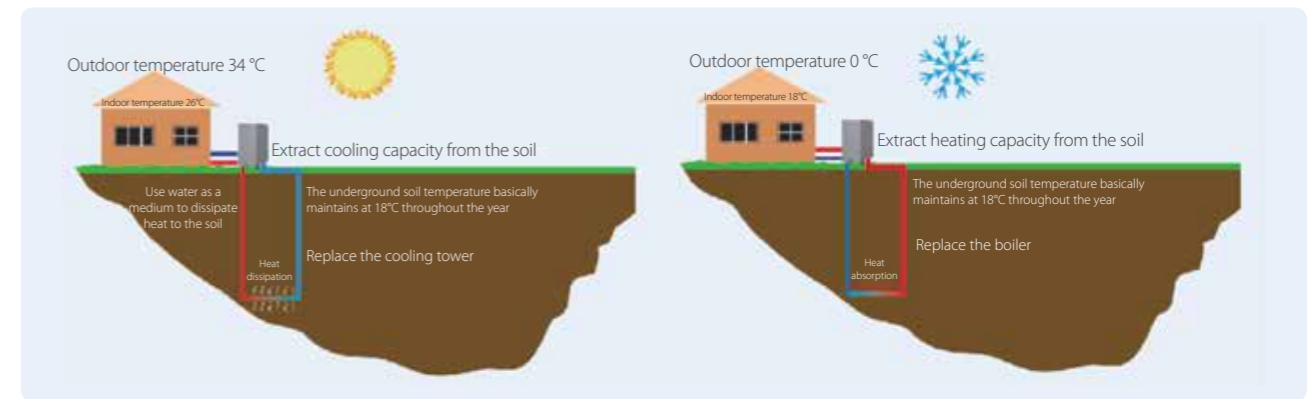

❖ Buried pipe ground-source heat pump system

The heat exchange pipes are installed under the ground, allowing them to exchange heat with the ground and achieve heating and cooling for the air conditioning system. Buried pipes can be divided into vertical and horizontal pipes. Vertical pipes are used in small-area sites, while horizontal pipes are used in large-area sites.

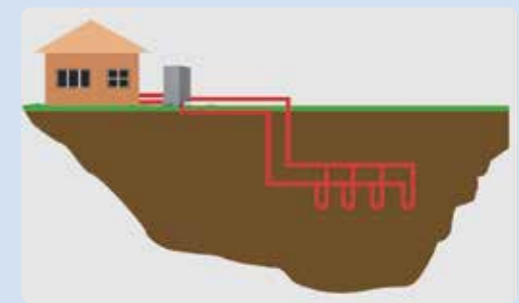

Buried pipe system

❖ Surface water-source heat pump system

The heat exchange pipes are installed in surface water sources such as lakes or ponds near the building, allowing them to exchange heat with the surface water and achieve heating and cooling for the air conditioning system.

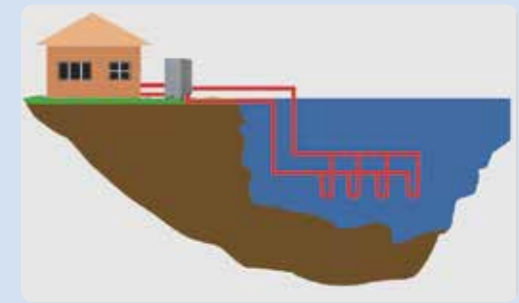

Surface water system

❖ Underground water-source heat pump system

Groundwater can be used directly as the cold and heat source of the air conditioning system. The water temperature of the groundwater loop is relatively stable, usually between 12°C and 15°C throughout the year.



Underground water system

Intelligent control

❖ Advanced microcomputer control board, real-time adjustment

The units are equipped with Midea's self-developed microcomputer control board, which supports operating control functions and safety protection. The high-speed processing chip can quickly obtain the operating parameters of the chiller system and promptly send control commands and carry out rapid processing to achieve intelligent control and ensure the stable operation of the unit.



Microcomputer control board

❖ Wired controller

Main functions:

- Touch key operation
- Parameter setting
- LCD display
- Multiple timers
- Real-time clock function
- Power-off memory function



Note:

Wired controller comes as standard accessory to control the chiller. Besides, we also offer colorful touch screen option. You can choose between the colorful touch screen and the wired controller.

❖ Advanced and user-friendly control system

One wired controller can achieve control of up to 16 units and manage the start and stop sequence of the unit. At the same time, users can view the operation status and fault status of the units through the wired controller.



❖ Midea Smart Cloud platform (optional)



Midea has built a flawless internet-based remote monitoring system, which provides customers with outstanding cloud service via advanced cloud service technologies and the internet. Customers can connect Midea air conditioner to the global remote monitoring system through Midea's IMU smart data acquisition terminal, so that professionals can help the customer to implement remote

fault diagnosis and analysis as well as receive early warning alarms for failures, ensuring the equipment's optimal operation. Customers authorized by Midea can use a Web browser to view the real-time monitoring data of the air conditioning system.

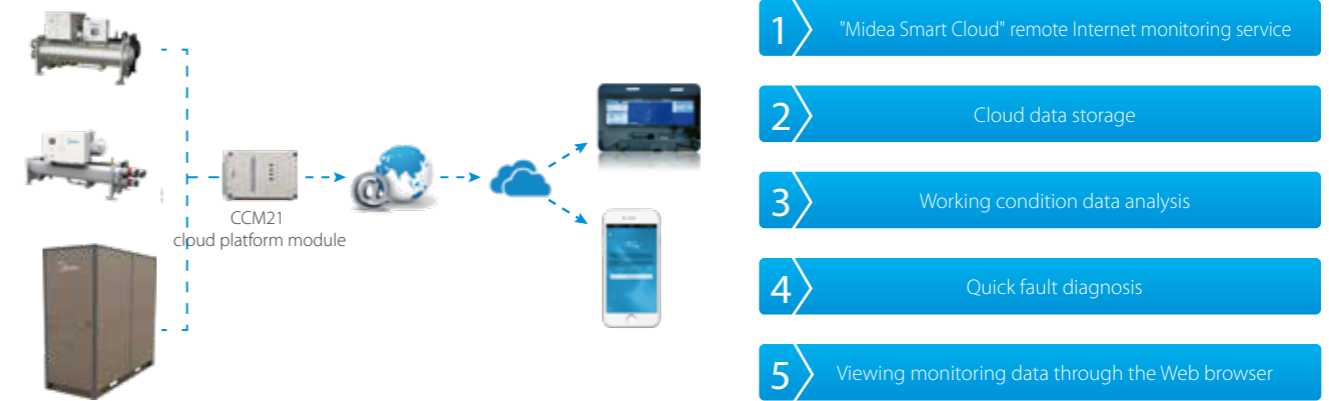

❖ Building management system (optional)

Modbus is an open protocol and is widely used, especially in building management system. Units can be connected to the BMS via Modbus to achieve remote control of up to 128 units.

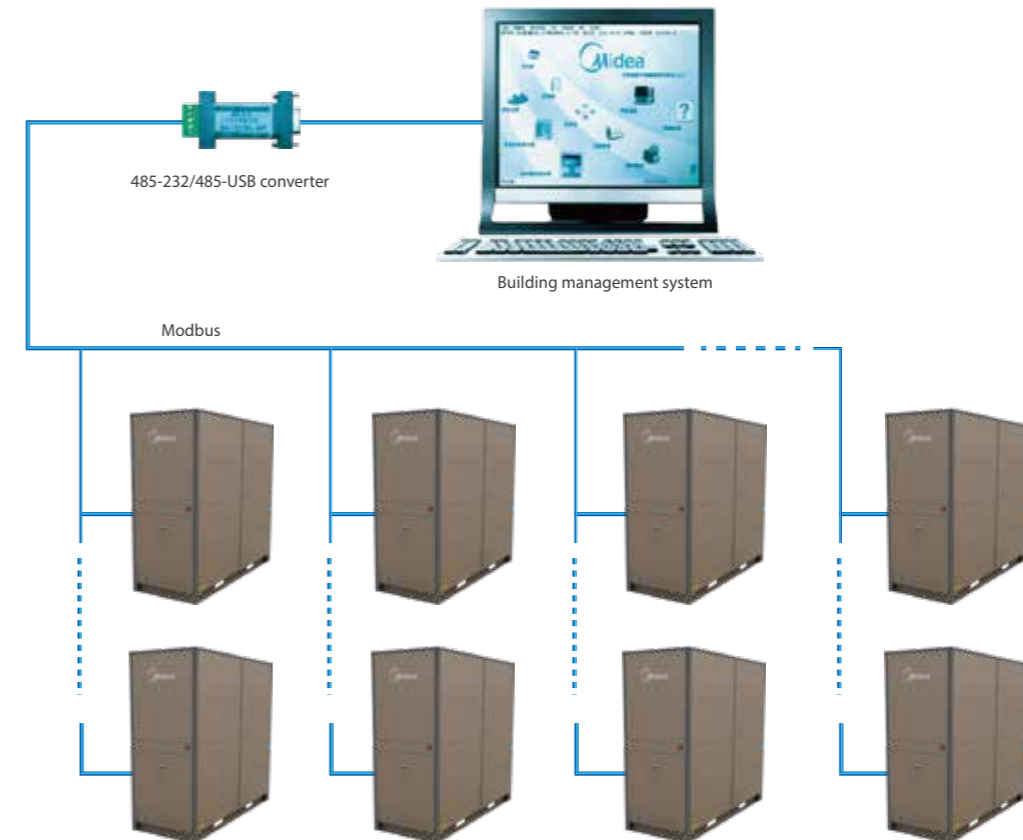

Specifications

Cooling operating range

Heat source side						User side	
Buried pipe type		Water-loop type		Underground water type			
Water inlet temperature (°C)	Water inlet/outlet temperature difference (°C)	Water inlet temperature (°C)	Water inlet/outlet temperature difference (°C)	Water inlet temperature (°C)	Water inlet/outlet temperature difference (°C)	Water outlet temperature (°C)	Water inlet/outlet temperature difference (°C)
10 to 40	2.5 to 8	20 to 40	2.5 to 8	10 to 25	8 to 13	5 to 15	2.5 to 8

Heating operating range

Heat source side						User side	
Buried pipe type		Water-loop type		Underground water type			
Water inlet temperature (°C)	Water inlet/outlet temperature difference (°C)	Water inlet temperature (°C)	Water inlet/outlet temperature difference (°C)	Water inlet temperature (°C)	Water inlet/outlet temperature difference (°C)	Water inlet temperature (°C)	Water inlet/outlet temperature difference (°C)
5 to 25	2.5 to 8	15 to 30	2.5 to 8	10 to 25	4 to 10	35 to 55	3.5 to 9

Notes:

- If the conditions of use are beyond the operating scope, please contact Midea.
- When buried pipes are used, the water temperature may reach or fall below 0°C. In this case, add glycol to the water to prevent freezing. Contact Midea for advice on the concentration of the glycol and performance correction.

Parameters of RCWE-HA(B) cooling only unit

Model	Unit	RCWE50HA(B)	RCWE75HA(B)	RCWE110HA(B)	RCWE145HA(B)		
Nominal Parameter	Cooling capacity	kW	155.0	242.5	362.0	481.0	
	Cooling power input	kW	29.0	45.0	67.5	89.8	
	Cooling COP	kW/kW	5.34	5.38	5.36	5.35	
	IPLV	kW/kW	6.42	6.45	6.44	6.43	
Sound pressure level	dB(A)	64	65	67	68		
Compressor	Type	/				Hermetic scroll compressor	
	Qty	System 1	/	1	1	2	2
		System 2	/	1	1	1	2
Energy regulation mode	/	50%/100%	50%/100%	33%/67%/100%	25%/50%/75%/100%		
Refrigerant	Name	/				R410A	
	Charge amount	System 1	kg	8.5	16	36	34
System 2		kg	8.5	16	18	34	
Power supply	/	380V-3Ph-50Hz					
Safety protection	/	High/low pressure/high discharge temperature/water flow switch/anti-freeze/motor overload/under-voltage/phase loss/phase sequence/oil heater/safety valve					
Start current	A	305.0	485.0	557.0	629.0		
Max. operating current	A	90.0	144.0	216.0	288.0		
Evaporator	Type	/				Shell and tube	
	Cooling water flow	m ³ /h	26.66	41.71	62.26	82.73	
	Cooling water pressure drop	kPa	39.0	61.0	60.0	49.0	
	Connection pipe diameter	mm	DN80	DN80	DN125	DN125	
Condenser	Type	/				Shell and tube	
	Cooling water flow	m ³ /h	33.33	52.14	77.83	103.4	
	Cooling water pressure drop	kPa	22.0	73.0	63.0	70.0	
	Connection pipe diameter	mm	DN80	DN80	DN125	DN125	
Unit dimensions	RCWE-HA series	Length	mm	1960	2520	2490	3080
		Width	mm	750	750	1050	1050
		Height	mm	1780	1860	2030	2030
	RCWE-HAB series	Length	mm	2010	2540	2540	3130
		Width	mm	750	750	1050	1050
		Height	mm	1800	2040	2040	2040
Shipping weight	RCWE-HA series	kg	900	1100	1950	2250	
RCWE-HAB series	kg	1000	1200	2100	2450		
Operating weight	RCWE-HA series	kg	1020	1260	2200	2500	
RCWE-HAB series	kg	1120	1360	2350	2700		

Notes:

- Cooling: the chilled water outlet temperature is 7°C and the water flow is the cooling capacity × 0.172m³/(h·kW), the cooling water inlet temperature is 30°C, the cooling water flow = cooling capacity × 0.215m³/(h·kW).
- The design's max working pressure of water side heat exchanger is 1.0 MPa and a victaulic connection is used. When ordering, specify whether a pressure higher than 1.0 MPa is needed and also if you require other types of connections.
- As a result of the continuous improvement of the product, the above parameters may be changed, please refer to the product nameplate and in-kind.

Buried pipe parameters of RHWE-HA(B) heat pump unit

Model	Unit	RHWE50HA(B)	RHWE75HA(B)	RHWE110HA(B)	RHWE145HA(B)		
Nominal parameter	Cooling capacity	kW	164.5	254.5	379.0	506.0	
	Cooling power input	kW	28.2	43.6	65.0	86.5	
	Cooling EER	kW/kW	5.83	5.83	5.83	5.85	
	Heating capacity	kW	170.0	268.5	400.0	531.0	
	Heating power input	kW	34.6	54.3	81.3	108.4	
	Heating COP	kW/kW	4.91	4.94	4.92	4.89	
Sound pressure level	dB(A)	64	65	67	68		
Compressor	Type	/				Hermetic scroll compressor	
	Qty	System 1	/	1	1	2	2
System 2		/	1	1	1	2	
Energy regulation mode	/	50%/100%	50%/100%	33%/67%/100%	25%/50%/75%/100%		
Refrigerant	Name	/				R410A	
	Charge amount	System 1	kg	8.5	16	36	34
System 2		kg	8.5	16	18	34	
Power supply	/	380V-3Ph-50Hz					
Safety protection	/	High/low pressure/high discharge temperature/water flow switch/anti-freeze/motor overload/under-voltage/phase loss/phase sequence/oil heater/safety valve					
Start current	A	305.0	485.0	557.0	629.0		
Max. operating current	A	90.0	144.0	216.0	288.0		
Evaporator	Type	/				Shell and tube	
	Cooling water flow	m ³ /h	28.29	43.77	65.19	87.03	
	Cooling water pressure drop	kPa	43.0	63.0	63.0	58.0	
	Heating water flow	m ³ /h	35.37	54.72	81.49	108.8	
	Heating water pressure drop	kPa	65.0	99.0	98.0	81.0	
Connection pipe diameter	mm	DN80	DN80	DN125	DN125		
Condenser	Type	/				Shell and tube	
	Cooling water flow	m ³ /h	35.37	54.72	81.49	108.8	
	Cooling water pressure drop	kPa	25.0	80.0	68.0	78.0	
	Heating water flow	m ³ /h	28.29	43.77	65.19	87.03	
	Heating water pressure drop	kPa	17.0	54.0	46.0	51.0	
Connection pipe diameter	mm	DN80	DN80	DN125	DN125		
Unit dimensions	RHWE-HA series	Length	mm	1960	2520	2490	3080
		Width	mm	750	750	1050	1050
		Height	mm	1780	1860	2030	2030
	RHWE-HAB series	Length	mm	2010	2540	2540	3130
		Width	mm	750	750	1050	1050
		Height	mm	1800	2040	2040	2040
Shipping weight	RHWE-HA series	kg	900	1100	1950	2250	
RHWE-HAB series	kg	1000	1200	2100	2450		
Operating weight	RHWE-HA series	kg	1020	1260	2200	2500	
	RHWE-HAB series	kg	1120	1360	2350	2700	

Notes:

- Cooling: the user-side water outlet temperature is 7°C and the user-side water flow = buried pipe cooling capacity × 0.172m³/(h·kW); the heat source side water inlet temperature is 25°C, the heat source side water flow = buried pipe cooling capacity × 0.215m³/(h·kW); Heating: the heat source side water inlet temperature is 10°C, the water flow is the same as that of the cooling mode, the user-side water outlet temperature is 45°C and the water flow is same as the user-side water flow of the cooling mode.
- The design's max working pressure of water-side heat exchanger is 1.0 MPa and a victaulic connection is used. When ordering, specify whether a pressure higher than 1.0 MPa is needed and also if you require other types of connections.
- As a result of the continuous improvement of the product, the above parameters may be changed, please refer to the product nameplate and in-kind.

Underwater parameters of RHWE-HA(B) heat pump unit

Model		Unit	RHWE50HA(B)	RHWE75HA(B)	RHWE110HA(B)	RHWE145HA(B)	
Nominal parameter	Cooling capacity	kW	172.0	268.0	398.0	533.0	
	Cooling power input	kW	26.3	40.7	60.3	80.9	
	Cooling EER	kW/kW	6.54	6.58	6.60	6.58	
	Heating capacity	kW	176.0	275.0	406.0	544.0	
	Heating power input	kW	34.4	53.8	80.3	107.2	
	Heating COP	kW/kW	5.11	5.11	5.05	5.07	
Sound pressure level		dB(A)	64	65	67	68	
Compressor	Type	/ Hermetic scroll compressor					
	Qty	System 1	1	1	2	2	
		System 2	1	1	1	2	
Energy regulation mode		/	50%/100%	50%/100%	33%/67%/100%	25%/50%/75%/100%	
Refrigerant	Name	/ R410A					
	Charge amount	System 1	kg	8.5	16	36	34
		System 2	kg	8.5	16	18	34
Power supply		/	380V-3Ph-50Hz				
Safety protection		/	High/low pressure/high discharge temperature/water flow switch/anti-freeze/motor overload/under-voltage/phase loss/phase sequence/oil heater/safety valve				
Start current		A	305.0	485.0	557.0	629.0	
Max. operating current		A	90.0	144.0	216.0	288.0	
Evaporator	Type	/ Shell and tube					
	Cooling water flow	m ³ /h	29.58	46.10	68.46	91.68	
	Cooling water pressure drop	kPa	47.0	73.0	71.0	63.0	
	Heating water flow	m ³ /h	18.06	28.14	41.79	55.97	
	Heating water pressure drop	kPa	19.0	29.0	28.0	24.0	
	Connection pipe diameter	mm	DN80	DN80	DN125	DN125	
	Condenser	Type	/ Shell and tube				
Cooling water flow		m ³ /h	18.06	28.14	41.79	55.97	
Cooling water pressure drop		kPa	8.0	25.0	21.0	23.0	
Heating water flow		m ³ /h	29.58	46.10	68.46	91.68	
Heating water pressure drop		kPa	18.0	59.0	50.0	56.0	
Connection pipe diameter		mm	DN80	DN80	DN125	DN125	
Unit dimensions	RHWE-HA series	Length	mm	1960	2520	2490	3080
		Width	mm	750	750	1050	1050
		Height	mm	1780	1860	2030	2030
	RHWE-HAB series	Length	mm	2010	2540	2540	3130
		Width	mm	750	750	1050	1050
		Height	mm	1800	2040	2040	2040
Shipping weight	RHWE-HA series	kg	900	1100	1950	2250	
	RHWE-HAB series	kg	1000	1200	2100	2450	
Operating weight	RHWE-HA series	kg	1020	1260	2200	2500	
	RHWE-HAB series	kg	1120	1360	2350	2700	

Notes:

- Cooling: the user-side water outlet temperature is 7°C and the user-side water flow = underground water cooling capacity × 0.172m³/(h·kW); the heat source side inlet temperature is 18°C, the heat source side flow = underground water cooling capacity × 0.103m³/(h·kW); Heating: the heat source side water inlet temperature is 15°C, the water flow is same as that of the cooling mode, the user-side water outlet temperature is 45°C and the water flow is same as the user-side water flow of the cooling mode.
- The design's max working pressure of water-side heat exchanger is 1.0 MPa and a victaulic connection is used. When ordering, specify whether a pressure higher than 1.0 MPa is needed and also if you require other types of connections.
- As a result of the continuous improvement of the product, the above parameters may be changed, please refer to the product nameplate and in-kind.

Water-loop parameters of RHWE-HA(B) heat pump unit

Model		Unit	RHWE50HA(B)	RHWE75HA(B)	RHWE110HA(B)	RHWE145HA(B)	
Nominal parameter	Cooling capacity	kW	155.0	242.5	362.0	481.0	
	Cooling power input	kW	29.0	45.0	67.5	89.8	
	Cooling EER	kW/kW	5.34	5.38	5.36	5.35	
	Heating capacity	kW	219.0	350.0	526.0	700.0	
	Heating power input	kW	37.9	60.5	90.3	121.0	
	Heating COP	kW/kW	5.77	5.78	5.82	5.78	
Sound pressure level		dB(A)	64	65	67	68	
Compressor	Type	/ Hermetic scroll compressor					
	Qty	System 1	1	1	2	2	
		System 2	1	1	1	2	
Energy regulation mode		/	50%/100%	50%/100%	33%/67%/100%	25%/50%/75%/100%	
Refrigerant	Name	/ R410A					
	Charge amount	System 1	kg	8.5	16	36	34
		System 2	kg	8.5	16	18	34
Power supply		/	380V-3Ph-50Hz				
Safety protection		/	High/low pressure/high discharge temperature/water flow switch/anti-freeze/motor overload/under-voltage/phase loss/phase sequence/oil heater/safety valve				
Start current		A	305.0	485.0	557.0	629.0	
Max. operating current		A	90.0	144.0	216.0	288.0	
Evaporator	Type	/ Shell and tube					
	Cooling water flow	m ³ /h	26.66	41.71	62.26	82.73	
	Cooling water pressure drop	kPa	39.0	61.0	60.0	49.0	
	Heating water flow	m ³ /h	33.33	52.14	77.83	103.4	
	Heating water pressure drop	kPa	58.0	95.0	90.0	74.0	
	Connection pipe diameter	mm	DN80	DN80	DN125	DN125	
	Condenser	Type	/ Shell and tube				
Cooling water flow		m ³ /h	33.33	52.14	77.83	103.4	
Cooling water pressure drop		kPa	22.0	73.0	63.0	70.0	
Heating water flow		m ³ /h	26.66	41.71	62.26	82.73	
Heating water pressure drop		kPa	15.0	49.0	42.0	47.0	
Connection pipe diameter		mm	DN80	DN80	DN125	DN125	
Unit dimensions	RHWE-HA series	Length	mm	1960	2520	2490	3080
		Width	mm	750	750	1050	1050
		Height	mm	1780	1860	2030	2030
	RHWE-HAB series	Length	mm	2010	2540	2540	3130
		Width	mm	750	750	1050	1050
		Height	mm	1800	2040	2040	2040
Shipping weight	RHWE-HA series	kg	900	1100	1950	2250	
	RHWE-HAB series	kg	1000	1200	2100	2450	
Operating weight	RHWE-HA series	kg	1020	1260	2200	2500	
	RHWE-HAB series	kg	1120	1360	2350	2700	

Notes:

- Cooling: the user-side water outlet temperature is 7°C and the user-side water flow = water-loop cooling capacity × 0.172m³/(h·kW); the heat source side water inlet temperature is 30°C, the heat source side water flow = water-loop water cooling capacity × 0.215m³/(h·kW); Heating: the heat source side water inlet temperature is 20°C, the water flow is same as that of the cooling mode, the user-side water outlet temperature is 45°C and the water flow is same as the user-side water flow of the cooling mode.
- The design's max working pressure of water-side heat exchanger is 1.0 MPa and a victaulic connection is used. When ordering, specify whether a pressure higher than 1.0 MPa is needed and also if you require other types of connections.
- As a result of the continuous improvement of the product, the above parameters may be changed, please refer to the product nameplate and in-kind.

Cooling and heating capacity correction curve

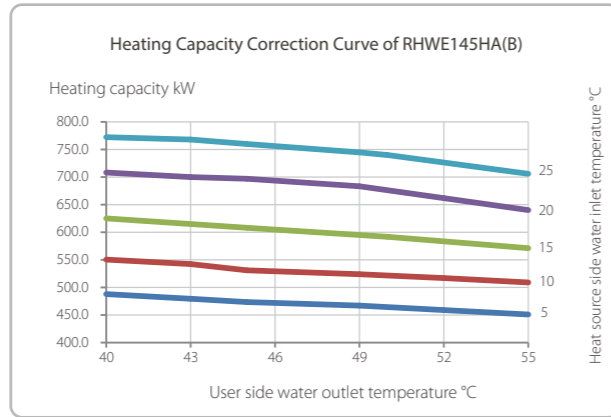
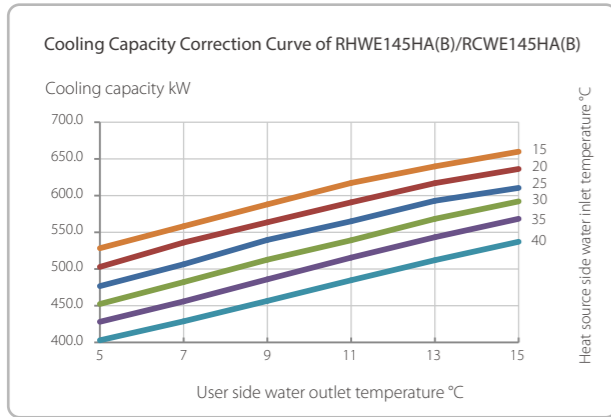
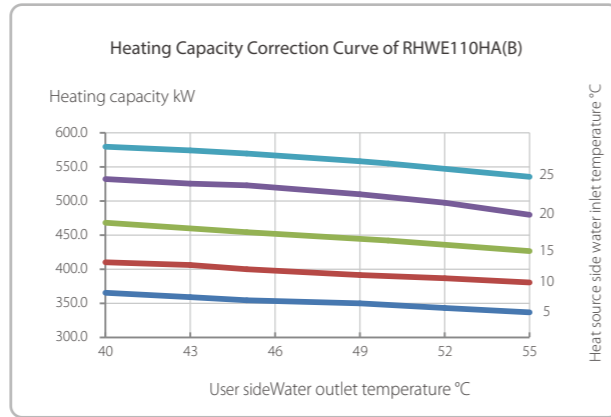
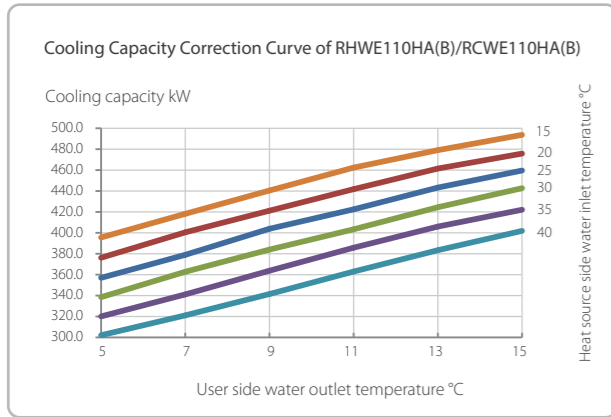
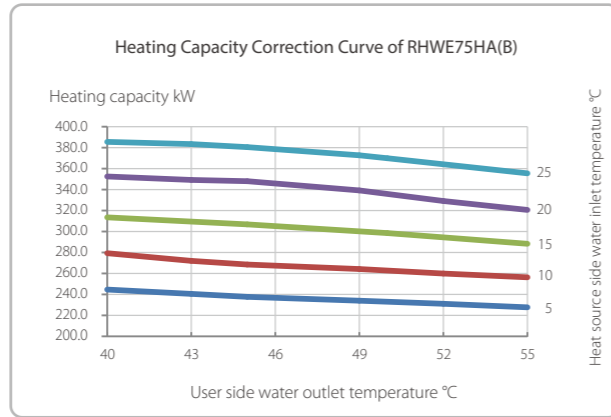
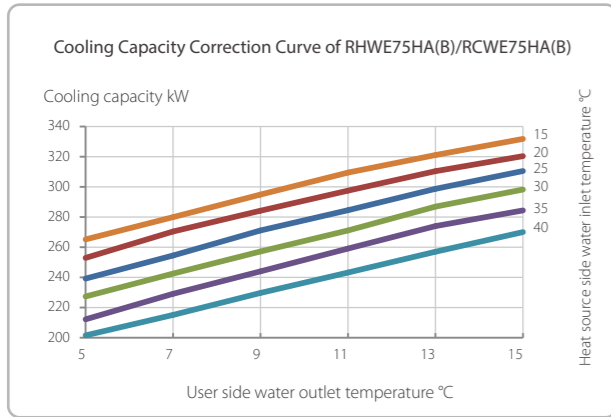
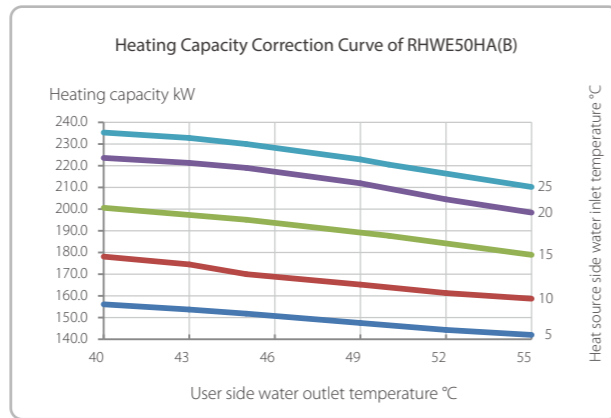
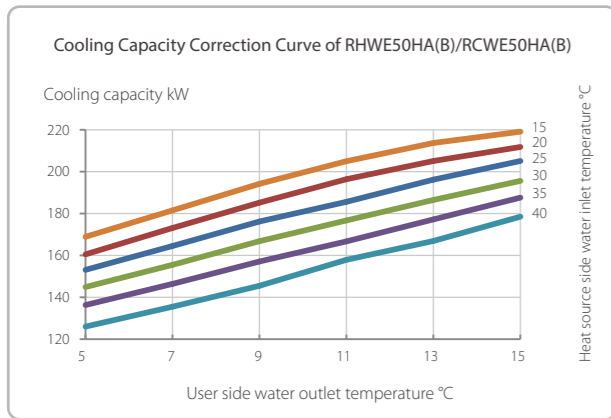

Installation

❖ Applicable model (with casing): RHWE50/75/110/145HAB (heat pump); RCWE50/75/110/145HAB (cooling only)

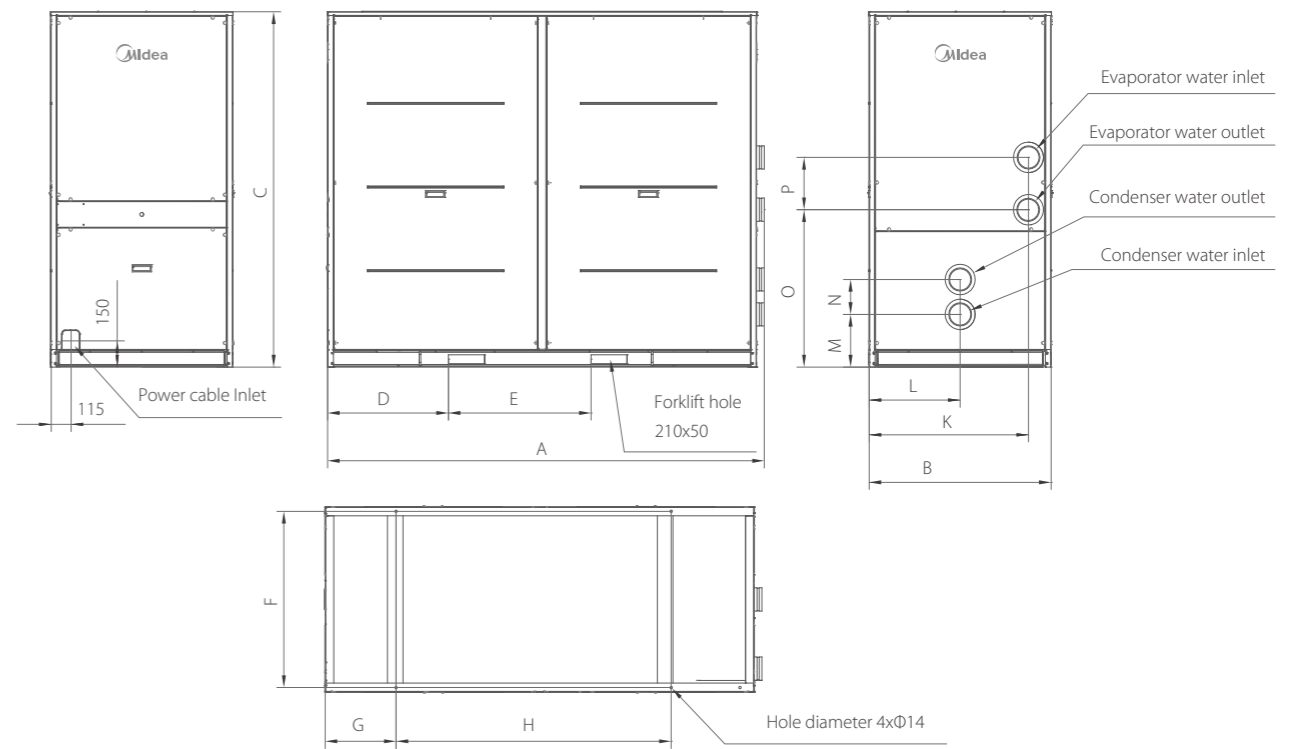

❖ Applicable model (without casing): RHWE50/75/110/145HA (heat pump); RCWE50/75/110/145HA (cooling only)

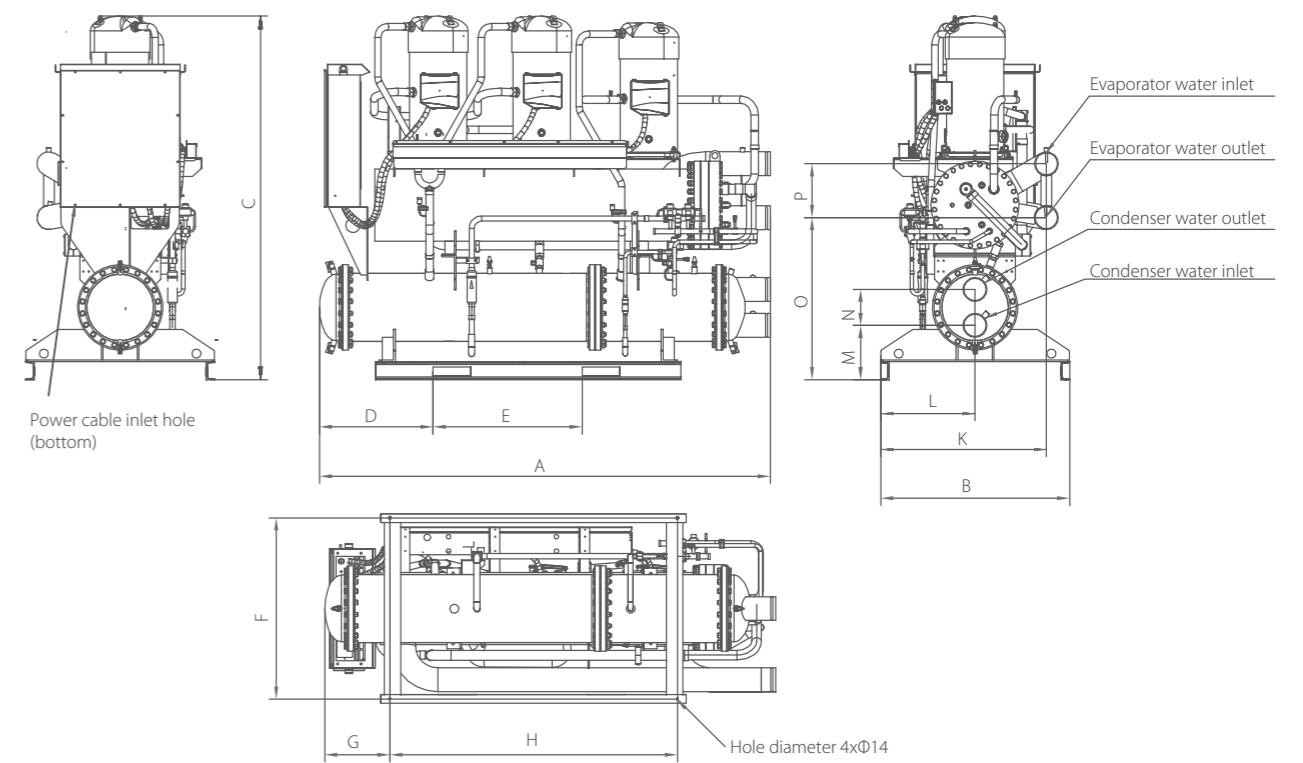

Note:
The internal structure of the different models varies. The above figure shows only the dimensions. The structure is for reference only.

Forklift and installation hole dimensions

Model	Unit: mm				
	D	E	F	G	H
RHWE50HA/RCWE50HA	420	800	705	390	1090
RHWE75HA/RCWE75HA	750	830	705	445	1600
RHWE110HA/RCWE110HA	675	830	1010	445	1600
RHWE145HA/RCWE145HA	900	830	1010	630	1600

Model	Unit: mm				
	D	E	F	G	H
RHWE50HAB/RCWE50HAB	470	800	705	390	1090
RHWE75HAB/RCWE75HAB	760	830	705	445	1600
RHWE110HAB/RCWE110HAB	705	830	1010	445	1600
RHWE145HAB/RCWE145HAB	930	830	1010	630	1600

Water inlet and outlet dimensions

Model	Unit: mm					
	K	L	M	N	O	P
RHWE50HA(B)/RCWE50HA(B)	625	375	280	140	715	220
RHWE75HA(B)/RCWE75HA(B)	650	375	280	140	850	275
RHWE110HA(B)/RCWE110HA(B)	920	525	300	200	900	300
RHWE145HA(B)/RCWE145HA(B)	920	525	300	200	900	300

Water inlet and outlet pipe sizes

Model	Unit: mm			
	Cooling water inlet	Cooling water outlet	Chilled water inlet	Chilled water outlet
RHWE50HA(B)/RCWE50HA(B)	DN80	DN80	DN80	DN80
RHWE75HA(B)/RCWE75HA(B)	DN80	DN80	DN80	DN80
RHWE110HA(B)/RCWE110HA(B)	DN125	DN125	DN125	DN125
RHWE145HA(B)/RCWE145HA(B)	DN125	DN125	DN125	DN125

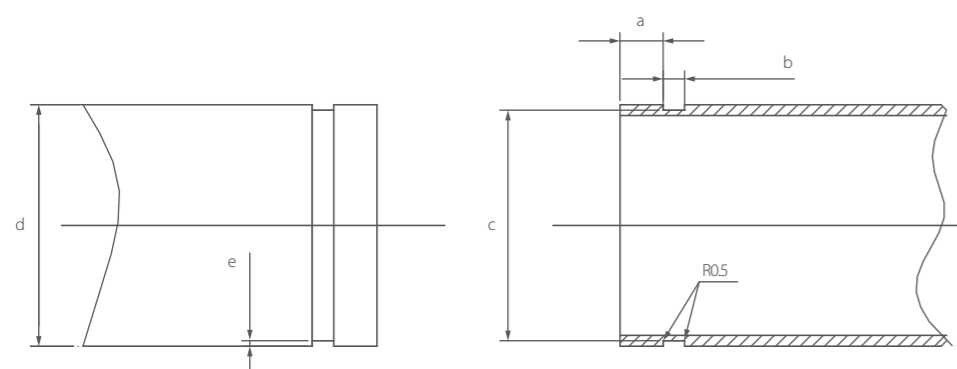

Water pipe size	Unit: mm				
	a	b	c	d	e
DN80	15.88	12.2	85	89x4	2
DN125	15.88	12.2	128	133x5	2.5

Note:
All the inlet and outlet pipes of the units must be connected and firmly secured with a victaulic.

Dimensions

Model	Unit: mm		
	A	B	C
RHWE50HA/RCWE50HA	1960	750	1780
RHWE75HA/RCWE75HA	2520	750	1864
RHWE110HA/RCWE110HA	2490	1050	2030
RHWE145HA/RCWE145HA	3080	1050	2030

Model	Unit: mm		
	A	B	C
RHWE50HAB/RCWE50HAB	2010	750	1800
RHWE75HAB/RCWE75HAB	2540	750	2040
RHWE110HAB/RCWE110HAB	2540	1050	2040
RHWE145HAB/RCWE145HAB	3130	1050	2040

Recommended spring isolator (mounting hole)

Model	Spring isolator at all points		
	P1	P2	Qty
RHWE50HA(B)/RCWE50HA(B)	MHD-320	MHD-320	4
RHWE75HA(B)/RCWE75HA(B)	MHD-450	MHD-450	4
RHWE110HA(B)/RCWE110HA(B)	MHD-730	MHD-730	4
RHWE145HA(B)/RCWE145HA(B)	MHD-850	MHD-850	4

Notes:

- The spring isolator is optional.
- The value in the spring isolator model indicates bearable weight (unit: kg). For example, "450" in "MHD-450" indicates 450kg.

Installation base requirements

The installation base should be designed by professional designers according to the site conditions. The installation foundation must be a cement or steel structure and should be able to bear the weight of the entire unit as well as maintenance personnel. A drain should be reserved. The horizontal and vertical error of the unit must not exceed 6mm/m. Otherwise, the unit must be adjusted until it is qualified. Do not bury the unit chassis in the foundation concrete.

The installation diagram is shown below.

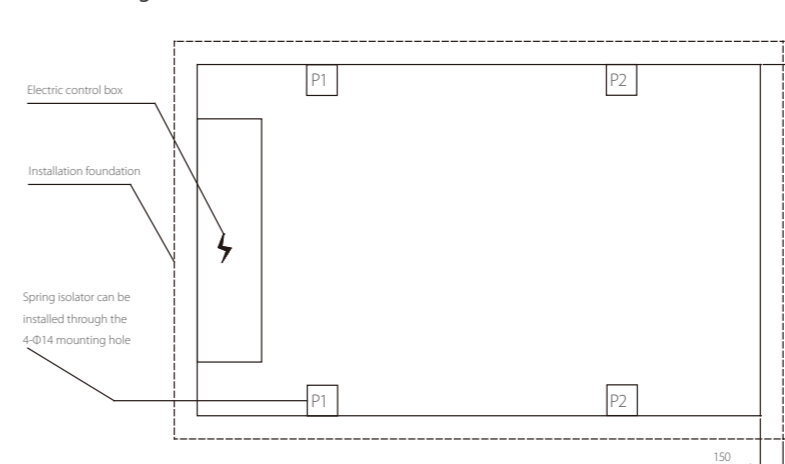

Note:

The ground bolt positions are marked by P1 and P2 in the above figure.

