

8C202405

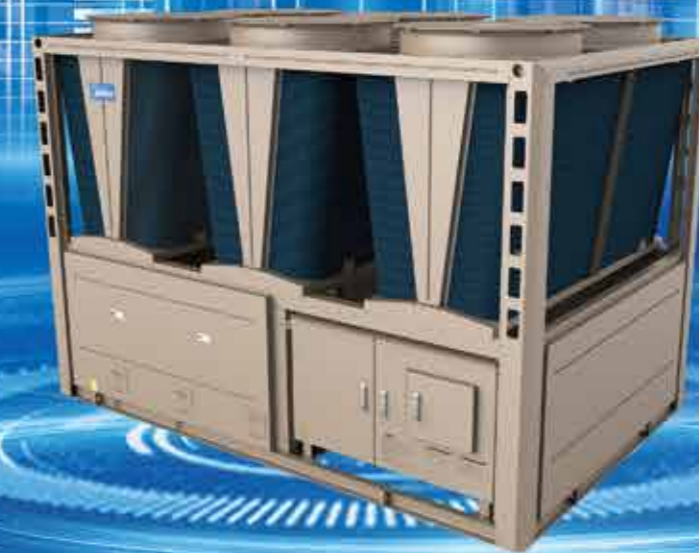

# Large Capacity Air Cooled Scroll Chiller RHAG/RCAG



**Midea Building Technologies Division**  
**Midea Group**

Add.: Midea Headquarters Building, 6 Midea Avenue, Shunde, Foshan, Guangdong, China  
Postal code: 528311

[mbt.midea.com/global](http://mbt.midea.com/global) [www.midea-group.com](http://www.midea-group.com) [ics.midea.com](http://ics.midea.com)

Midea reserves the right to change the specifications of the product, and to withdraw or replace products without prior notification or public announcement. Midea is constantly developing and improving its products.



**2024**

MAKE A BEAUTIFUL TOMORROW

# Midea MBT

Midea MBT(Midea Building Technologies) is a key division of the Midea Group, a leading provider of comprehensive solutions of intelligent building, involving energy sources, elevators, control systems, and heating, ventilation & air conditioning. Midea MBT has continued with the tradition of innovation upon which it was founded and emerged as a global leader in the HVAC and building management industry. A strong drive for advancement has resulted in an extensive R&D department that has placed Midea MBT at the forefront of a competitive edge. Through these independent projects and joint-cooperation with other global enterprises, Midea has supplied thousands of innovative solutions to customers worldwide.

Several production bases are situated on Shunde, Chongqing, Hefei, and Italy.

MBT Shunde: 38 product lines focusing on VRF, Split Products, Heat Pump Water Heaters and AHU/FCU.

MBT Chongqing: 14 product lines focusing on Water Cooled Centrifugal/Screw/Scroll Chillers, Air Cooled Screw/Scroll Chillers and AHU/FCU.

MBT Hefei: 11 product lines focusing on VRF, Chillers and Heat Pump Water Heaters.

Clivet S.p.A: 50,000m2 workshop in Feltre and Verona, covering products such as ELFO system, hydronic, WHLP, packaged, split and close control and so on.





# MBT Learning Academy

## Objective

MBT Learning Academy aims to provide training to the sales personnel as well as technical personnel in order to increase the utilization for your MBT equipment. Once you have purchased equipment from MBT, taking care of the equipment is topmost priority. MBT Learning Academy offers training courses to learn firsthand from the manufacturer what it takes to get the best out of your MBT product. The goal of MBT Learning Academy is to provide product specific training, safe work procedures and expertise in carrying out the installation and maintenance of MBT products as well as teaching the main selling points in order to help the sales people sell the MBT products with ease.

## Training Centers

Our world class training centers provide knowledge and skills necessary to efficiently deploy MBT technologies. The training centers include dedicated laboratories to provide hands-on experiences with various systems, components and controls to refresh and enhance the skills of your sales, design and installation and service teams. Right now we operate our trainings from the below two locations:

### 1. MBT Training Center

**Address:** MBT Training Center, 2nd Floor, Building 6, Midea Global Innovation Center, Beijiao, Shunde, Foshan, China Pin-528311

The Midea MBT Training Center is situated 70 kilometers from Baiyun Guangzhou International Airport.

**Products:** VRF, M thermal

### 2. Chongqing Midea Training Center

**Address:** No. 15, Qiangwei Road, Nan'an District, Chongqing, China

Chongqing Midea Training Center is 35 kilometers from Chongqing International Airport.

**Products:** Centrifugal Chiller, Screw/Scroll Chiller and Terminals



VRF training



M thermal training



Chiller training

## Global Technical Trainings

The training courses by MBT Learning Academy are divided into the following two categories with different targeted audiences for each.

**Design and Application Trainings:** The design and application trainings for various products are basically for the sales personnel selling MBT products in order to give them basic understanding about the main features. The trainings are conducted on a global level inviting sales engineers, technical engineers, consultants and project designers from different parts of the world.

**After Sales- Service Trainings:** These trainings are dedicated for the After Sales/ Service personnel in order for them to better carry out the installation, commissioning and maintenance of MBT products. Technical person and engineers from different parts of the world are invited to take part in these trainings.

**Online Trainings:** The trainings to the Global customers can also be done online with the help of Team and Midea Meeting software. This way, the customers do not need to be physically present for the training. Amid the COVID-19 pandemic, MBT Learning Academy has conducted a lot of online trainings. The training videos are available on the ICS system and can be downloaded by using QR codes.

**Products:** VRF, M thermal, Chillers and Terminals

**Highly Skilled Trainers:** The trainers for various courses by MBT Learning Academy are expert people with vast experiences in their field. Most of them have a deep insight about the global HVAC market and help the attendees to better understand the MBT products.

**Training Certificates:**

The attendees for Global trainings are provided a training certificate highlighting the courses discussed in the training, signed by Mr. Henry Cheng, General Manager of MBT Overseas Sales Company.

**Registration:**

You can contact your respective Midea contact point to provide you with the complete schedule about the global technical trainings as well as how to register for these trainings.

For further enquiries about the Global Trainings conducted by MBT Learning Academy, please send email at the following email address: [peeyush@midea.com](mailto:peeyush@midea.com)



Chiller After Sales Courses



Chiller Introduction Courses

# Midea Global Spare Parts Center

The global spare parts center provides high quality and fast spare parts supply. Midea online system (<https://ics.midea.com>) can query and purchase spare parts with one click, further shortening the supply time of spare parts.

The “**2** (HQ Spare parts center) + **10** (Regional Spare parts center) + **N** (Country Spare parts inventory)” Spare Parts Layout can ensure the timely supply of global after-sales spare parts.



# International Service Management (ICS)

ICS is a platform for customers to seek professional technical support. Through ICS, you can inquire about product information, documentation, spare parts and troubleshooting, ask technical questions, submit complaints, and order spare parts.

<https://ics.midea.com>



### My order

Inquire about spare parts from an exploded view and place orders for spare parts directly in ICS.

### Document inquiry and download

View or download product technical documentation online, such as catalogs, images, training PPTs, etc.

### Technical inquiry & FAQ

Ask technical questions online and receive a prompt response from our technicians. Or find a quick solution in the FAQ.

### Troubleshooting

Query the error code and solution by SN, model name, error code or product type.

### Complain

Submit product quality complaints online, and our after-sales engineers will respond promptly.



# Mobile Intelligence Service App (MISA)

MISA is the mobile terminal of ICS, with the same functions as ICS. The mobile service improves the response time and convenience of technical support.

<https://link.midea.com>



FAQ



Complain



Technical Enquiry



Trouble shooting

Download

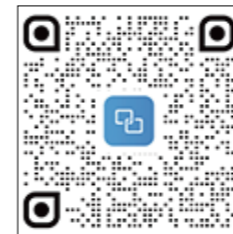

Scan to download the mobile app

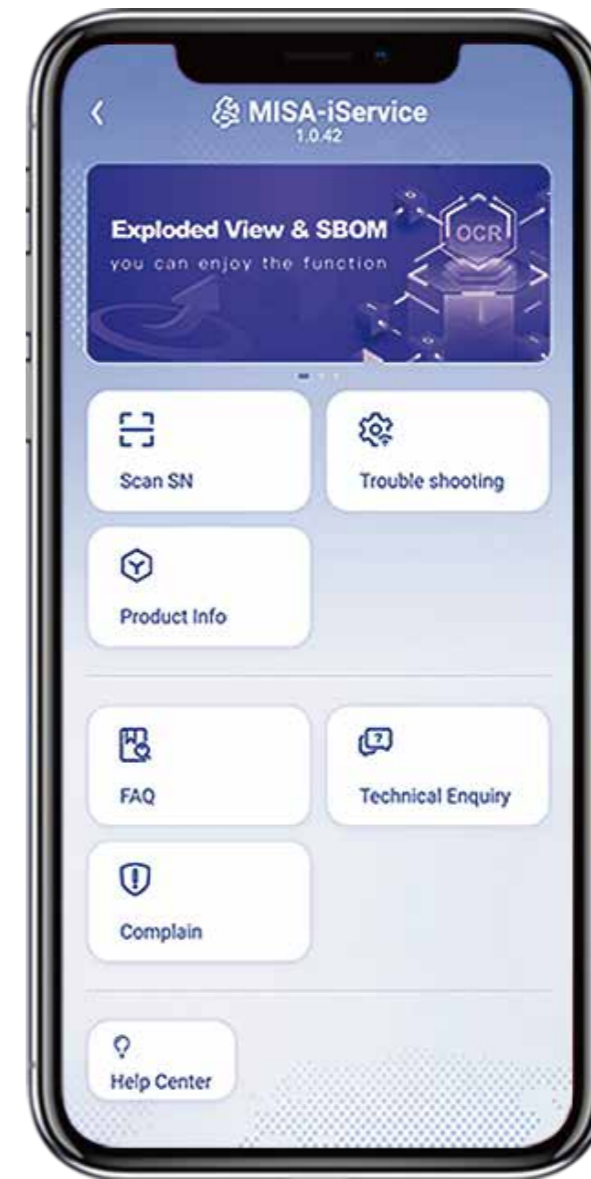

Search product manuals



Spare parts list

Feedback



Thank you for your attention and feedback



## Cities Need Cleaner Heating Solutions

Higher living standards means more people want solutions for cooling in summer and heating in winter. Air cooled heat pump unit is an excellent choice for meeting these requirements. However, due to technology bottlenecks, the heating effect in winter is limited by ambient temperature. Meanwhile, frequent shutdowns make users uncomfortable when switching between heating and cooling because of defrosting. Midea large capacity air cooled scroll chiller uses clean energy to produce heat instead of traditional coal-fired boilers. The wider range of ambient temperature, strong heating effect at low temperatures in winter, intelligent defrosting and small outlet water temperature fluctuations heat cold areas for greater comfort. The green R410A refrigerant and low operating noise minimize environmental impact. The product features a modular design for seamless connections and reduced installation space, bringing more benefits to customers.

## Content



- [11 Overview](#)
- [13 Features](#)
- [19 Specifications](#)
- [21 Dimensions and base diagrams](#)
- [27 Options](#)
- [28 Installation and Maintenance](#)
- [31 Intelligent Management](#)
- [33 Reference Projects](#)

# Overview

Midea large capacity air cooled scroll chiller adopts a modular design. Two basic modules: 340kW and 460kW. Maximum 8 units can be combined and the maximum cooling capacity is 3680kW. The unit can be widely used in various buildings, including hotels, hospitals, schools, factories, office buildings etc.

## Core advantages

- Heat Pump/ Cooling Only
- Eco-Friendly
- Quiet Operation
- Flexible Installation
- Wide Operation Range
- Intelligent Control

## Nomenclature

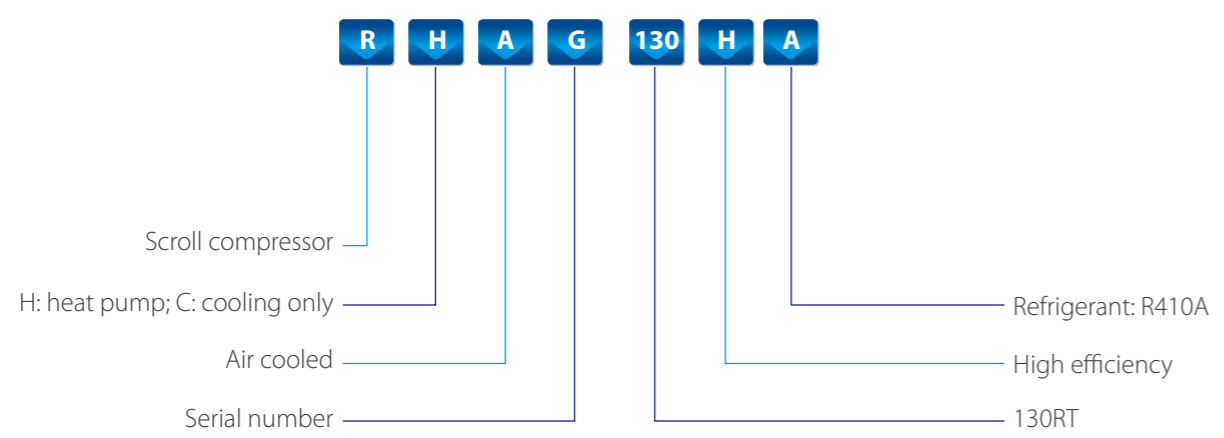

## Operating range

Operating condition	Cooling	Heating
Ambient temperature	0~48°C	-15~48°C
Water outlet temperature	5~20°C	20~50°C

**Trapezoidal heat exchanger**

Annular air inlet structure, face area of heat exchanger increases by 30%. More uniform air distribution and better heat exchange.

**Fan and motor**

Large air flow and low noise fan. High torque fan, high efficiency and low noise.

**Electric control box**

Leading brand components are adopted to ensure quality. The electric control box is designed on the front side to make installation fast and maintenance convenient.

**Touch screen**

The large 7-inch colorful touch screen makes man-machine interaction user friendly.



**Water side heat exchanger**

The new design of baffle plate shell and tube evaporator improves 10% heat exchanging efficiency.

**Gas-liquid separator**

Gas-liquid separator ensures reliable operation of the system.

**Danfoss large capacity compressor**

Higher efficiency and longer life span.

### High efficiency water side heat exchanger

- ❖ The optimized design of simulation flow path and baffle plate are adopted to enhance heat transfer efficiency.
- ❖ The efficiency of the heat exchanger is increased by 10% compared with that of ordinary shell and tube heat exchanger.

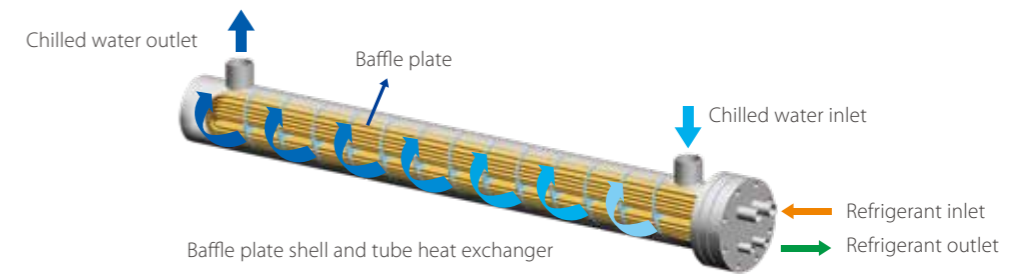

### High efficiency air side heat exchanger

- ❖ Annular air inlet structure, face area of heat exchanger increases by 30%.
- ❖ Arc window structure hydrophilic aluminum fins, reduce pressure loss.
- ❖ High efficiency inner-threaded copper pipes greatly enhance heat exchange.
- ❖ The distribution method and the use of simulation flow optimization design, greatly improved heat exchange efficiency.

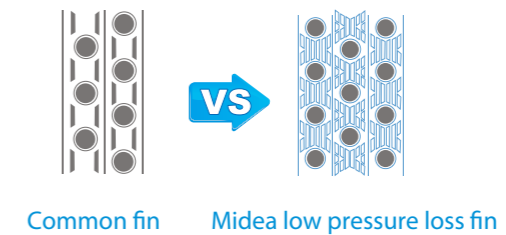

### High precision EXV, more accurate temperature control

- ❖ The EXV used is highly precise which takes only a few seconds to go from fully closed to fully open state.
- ❖ There is no static superheat phenomenon and can realize low load start. This reduces the heat loss in shutdown and enhances the stability and reliability of the unit.

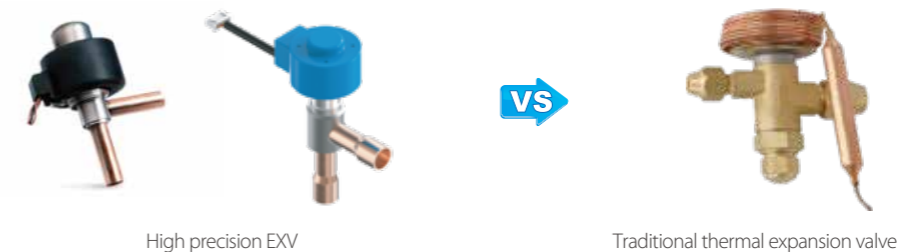

## Features

### Hermetic scroll compressor

#### High efficiency

Adopt the scroll design without contact and wear, reduce the friction inside the compressor, improve the efficiency.

#### Low warranty cost

Eco-friendly lead-free polymer bearing, stable operation and help to reduce warranty cost.

The actual compressor maybe slightly different from the picture shown.

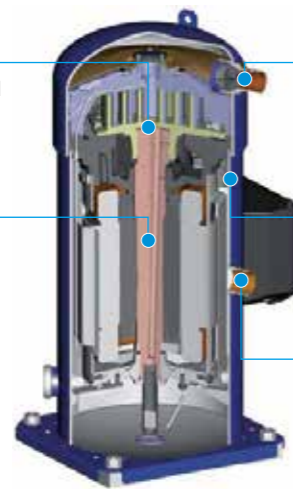

#### Stable performance

Compressor outlet is equipped with check valve to avoid backflow of refrigerant and high reliability.

#### No need for maintenance

Hermetic design, no need for maintenance.

#### Long service life

Suction refrigerant cooled motor, higher efficiency and longer service life of compressor.

### IDV (intermediate discharge valve)

The compressor adopts an intermediate discharge valve design. The system can operate efficiently under full pressure ratio to achieve high operating efficiency.

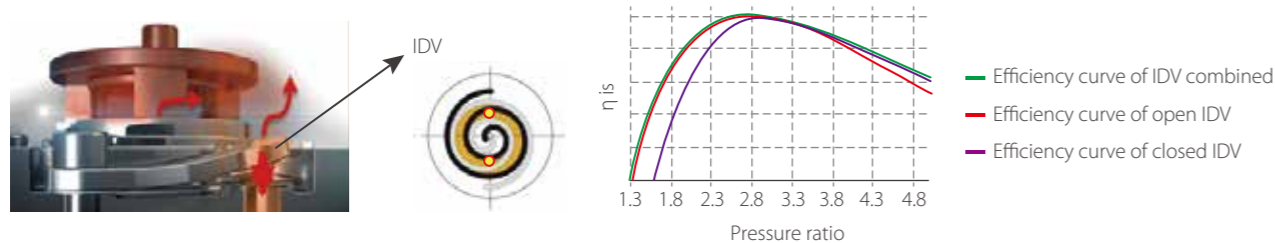

### Built-in discharge temperature sensor

Installed in the vantage point of the compressor, it can timely sense the discharge temperature and perform the function immediately when the operation state of the compressor exceeds the safety limit and send a signal to the motor protection system to protect the compressor.



### Oil balance pipe

Under partial load conditions, the parallel compressor unit can store the lubricating oil in the unrunning compressor, thus greatly improving the reliability of the system. In addition, the oil stored in the compressor can improve the heat transfer effect in the evaporator, thus greatly improving the efficiency of the system.



### Check valve

The top cover is kept in balance at the low pressure end after the compressor stops, so as to avoid excessive leakage at the high pressure end and ensure no-load start, which can improve the reliability of the compressor.



### Comfortable heating

- ❖ Powerful low-temperature heating performance and advanced pressure ratio control technology ensures efficient and stable heating operation in low temperature environment.
- ❖ The heating attenuation at -15°C is less than 38%.
- ❖ Intelligent defrosting avoids wasting energy when there is no need for defrosting.

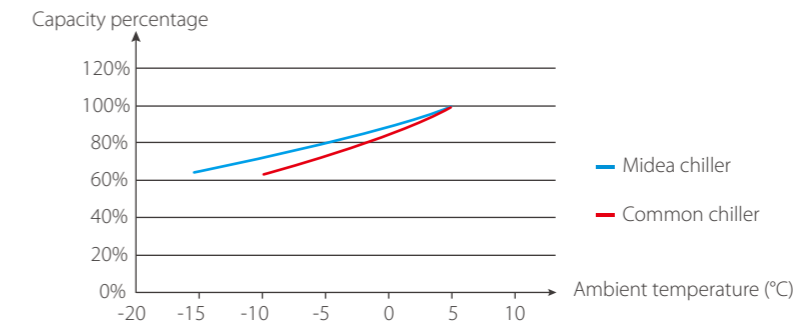

### Patented online self-learning defrosting technology based on fuzzy logic

It can automatically determine defrosting, reduce heating capacity attenuation caused by frequent defrosting, reduce water temperature fluctuation and improve system reliability.

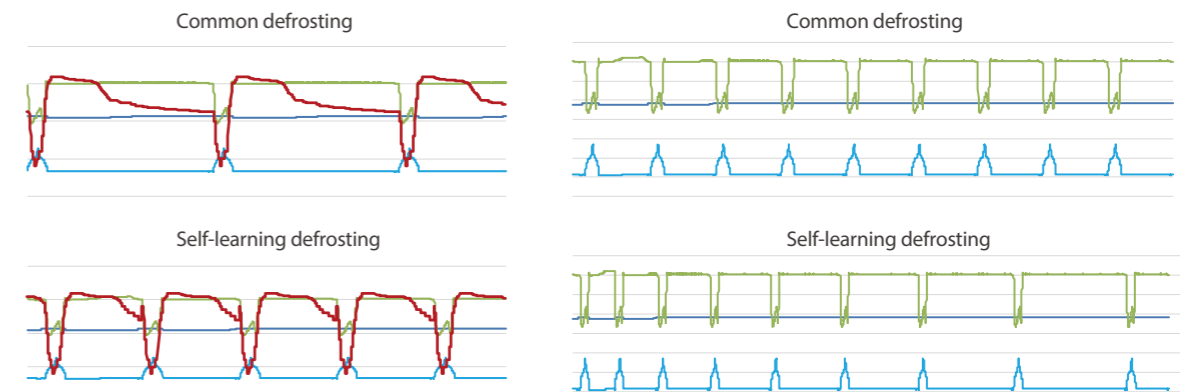

In high humidity condition, frost formation is fast and thick. By timely defrosting, the unit can keep running in high capacity.

In low humidity condition, the frosting of the unit is slow and less frost. By extending the heating interval, the frosting times can be reduced.

### Quiet operation

- ❖ High efficiency and low noise fan design.
- ❖ The fan impeller is optimized with professional flow field software to ensure good aerodynamics and a larger air flow with less noise, improving the heat exchange on the air side.
- ❖ The noise reduction box for the compressor makes the running noise of the unit greatly reduced.



Low noise fan

Low noise compressor

Noise reduction box for compressor (optional)

### Reliable oil system

- ❖ Low pressure chamber compressor with vertical structure, oil tank is at the bottom of the compressor.
- ❖ For parallel compressor units, two compressors are in one group and connected by oil balance pipe. The oil balance pipe is located below the oil level to ensure the oil pressure balance for the compressors.
- ❖ The system pipeline is equipped with a gas-liquid separator, which can effectively prevent the liquid strike and make the compressor run more stably.
- ❖ With oil-collecting design in the suction pipe, it can effectively prevent the migration of oil and refrigerant to the compressor during shutdown under extreme low load conditions.

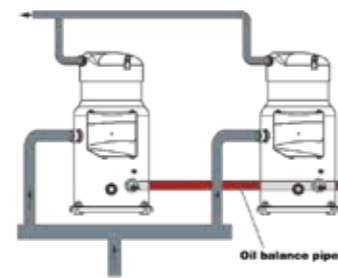

### Eco-friendly

- ❖ R410A does not contain chlorine that depletes the ozone layer and its Ozone Depletion Potential (ODP) value is 0, fully protecting the environment.
- ❖ Helpful to obtain green building, LEED and other building certifications.

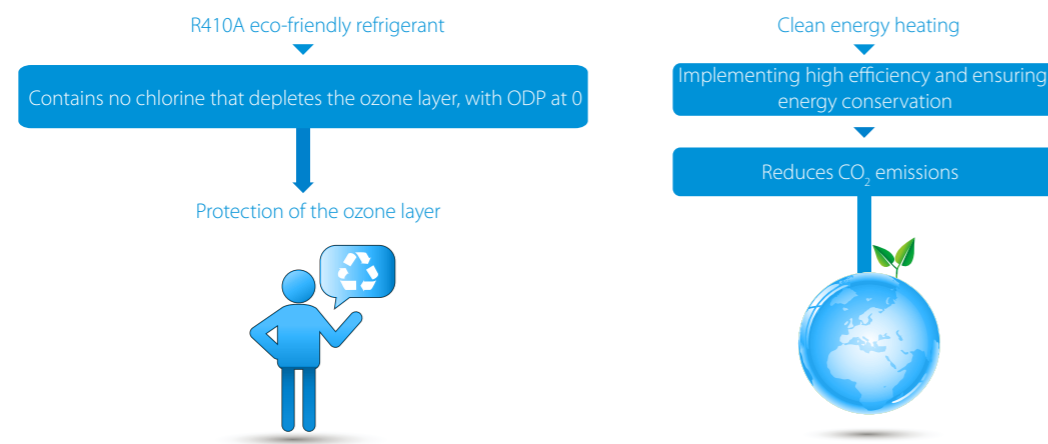

### Wide operation range

Cooling mode: 0°C to 48°C. Heating mode: -15°C to 48°C.

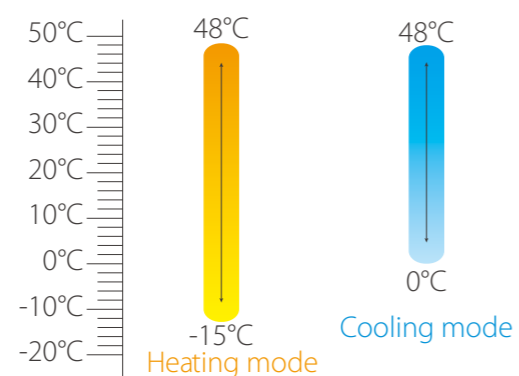

### Optional applications

#### Heat recovery

- ❖ Air cooled chiller discharges a lot of condensation heat to the air during cooling, leading to great energy wastage. The heat recovery unit can provide "free" domestic hot water at up to 60°C during cooling, making full use of energy, reducing waste heat emissions and costs.
- ❖ The unit especially suits hotels, hospitals, bath centers, factories and so on, where users require cooling and hot water for living or processes at the same time.

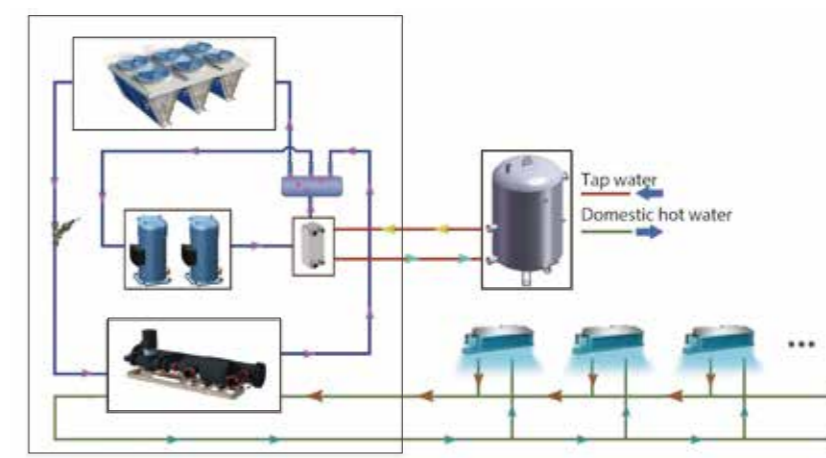

#### Built-in hydraulic module

- ❖ The built-in hydraulic module integrates all the necessary components such as the water pump, filter, expansion water tank, flow switch, safety valve, air discharge valve, pressure gauge and flow control valve, to greatly reduce initial system investment and design and installation workloads, saving time, effort and money.
- ❖ The Victaulic water pipe connection is more convenient and reliable, not only simplifying installation but also isolating vibrations.
- ❖ The high lift and ultra high lift options are provided to meet different requirements.



#### Wired controller

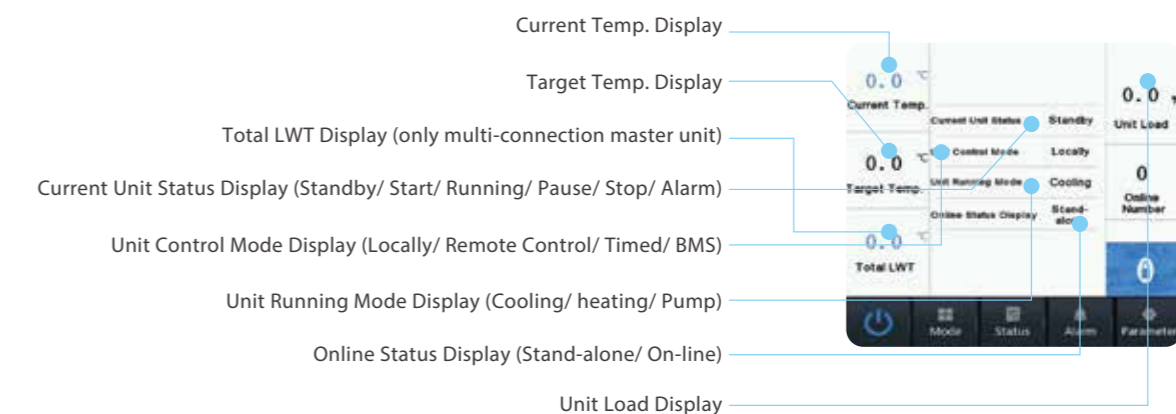

### Seamless connection

- ❖ Modular design concept, free combination to meet different capacity requirements. Possible to increase capacity in the future expansion.
- ❖ The "V" module design allows lateral ventilation and heat exchange. Multiple modules can be seamlessly connected to reduce the installation area.

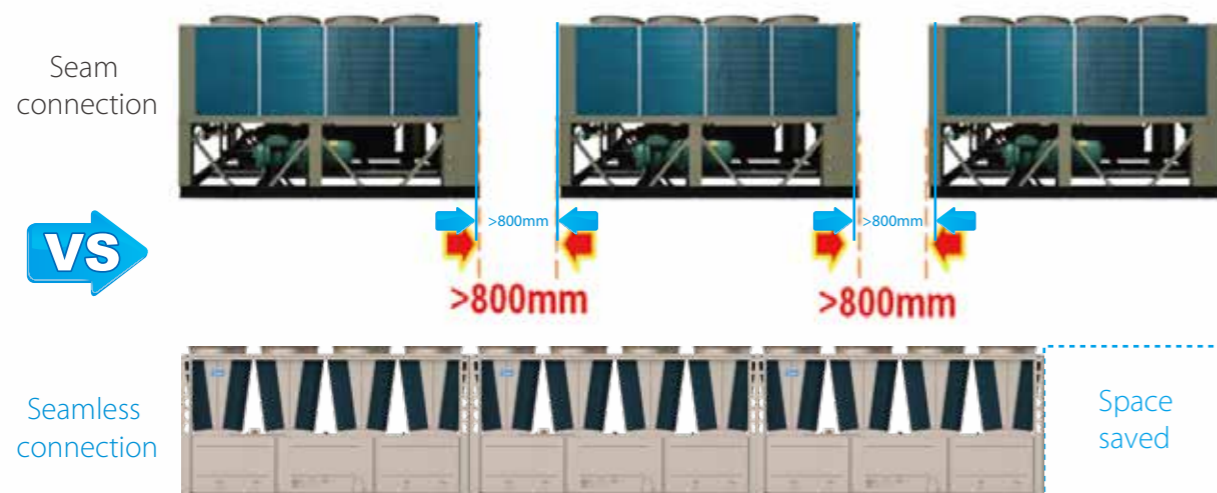

### Advanced microcomputer control

Independently developed advanced microcomputer control panel, with multiple functions such as product operation control function and safety protection. Among them, the high-speed processing chip can quickly obtain the operating parameters of the chiller system and timely issue control instructions for rapid processing, so as to realize the intelligent control of the unit and ensure the stable operation of the unit.



### Colorful Touch Screen

- ❖ Complete control functions  
The control functions that can be realized include: self-set outlet water control temperature, load intelligent control, self-equipped Master&Slave control, intelligent defrosting, intelligent low temperature control etc.
- ❖ Complete protection functions  
High pressure protection, low pressure protection, overload protection, discharge temperature protection, water flow protection, pressure ratio protection, discharge superheat protection etc.



# Specifications

## Heat pump

Model		RHAG	100HA	130HA	200HA	230HA	260HA	
Nominal parameter	Cooling capacity	kW	340.0	460.0	680.0	800.0	920.0	
	Cooling power input	kW	102.5	138.0	205.0	240.5	276.0	
	Cooling COP	W/W	3.317	3.333	3.317	3.326	3.333	
	IPLV	W/W	4.813	4.721	4.813	4.759	4.721	
	Heating capacity	kW	355.0	475.0	710.0	830.0	950.0	
	Heating power input	kW	102.0	137.5	204.0	239.5	275.0	
	Heating COP	W/W	3.480	3.454	3.480	3.466	3.454	
	Partial heat recovery*	kW	102.0	138.0	204.0	240.0	276.0	
Compressor	Type	/	Hermetic scroll compressor					
	Quantity	System 1	/	2	2	2	2	2
		System 2	/	1	2	1	1	2
		System 3	/	-	-	2	2	2
		System 4	/	-	-	1	2	2
Energy regulation mode	/	Adaptive energy regulation						
Refrigerant	Type	/	R410A					
	Charge amount	System 1	kg	38	38	38	38	38
		System 2	kg	18	38	18	18	38
		System 3	kg	-	-	38	38	38
		System 4	kg	-	-	18	38	38
Power supply	/	380V-3Ph-50Hz						
Rated current	A	181.5	244.3	181.5/181.5	181.5/244.3	244.3/244.3		
Start current	A	589.0	673.0	589.0/589.0	589.0/673.0	673.0/673.0		
Max. operating current	A	257.7	343.6	257.7/257.7	257.7/343.6	343.6/343.6		
Air side heat exchanger	Type	/	High efficiency internal thread pipe + hydrophilic aluminum fin					
	No. of fan	/	6	8	12	14	16	
	Air flow rate	m³/h	20000×6	20000×8	20000×12	20000×14	20000×16	
	Motor power input	kW	1.300×6	1.300×8	1.300×12	1.300×14	1.300×16	
	Water side heat exchanger	Type	/	Shell and tube				
Water flow rate		m³/h	58.48	79.12	117.0	137.6	158.2	
Pressure drop		kPa	63.0	63.0	63.0	63.0	63.0	
Water pipe connection		mm	DN125	DN125	DN125/DN125	DN125/DN125	DN125/DN125	
Max. working pressure		kPa	1000					
Fouling factor		m²·°C/kW	0.018					
Built-in hydraulic module (optional)*	Pump type	/	Single-stage piping centrifugal pump					
	No. of pump	/	1	1	2	2	2	
	Pump power input (high lift)	kW	7.5	11	7.5/7.5	7.5/11	11/11	
	Pump power input (ultra high lift)	kW	11	15	11/11	11/15	15/15	
	External water head (high lift/nominal flow)	kPa	198.0	223.4	198.0/198.0	198.0/223.4	223.4/223.4	
	External water head (ultra high lift/nominal flow)	kPa	304.8	309.0	304.8/304.8	304.8/309.0	309.0/309.0	
	Expansion tank capacity	L	80	80	80/80	80/80	80/80	
	Max. water side pressure (with built-in hydraulic module)	kPa	1000	1000	1000	1000	1000	
	Inlet and outlet pipe (with built-in hydraulic module)	mm	DN125	DN125	DN125/DN125	DN125/DN125	DN125/DN125	
	Partial heat recovery heat exchanger (optional)*	Type	/	Plate heat exchanger				
Water flow rate		m³/h	5.8	7.9	5.8/5.8	5.8/7.9	7.9/7.9	
Pressure drop		kPa	11.3	12.8	11.3/11.3	11.3/12.8	12.8/12.8	
Connecting pipe diameter		mm	DN50	DN50	DN50/DN50	DN50/DN50	DN50/DN50	
Unit dimensions	Length	mm	3530	4700	7060	8230	9400	
	Width	mm	2300	2300	2300	2300	2300	
	Height	mm	2500	2500	2500	2500	2500	
Unit weight	kg	2900	3870	5800	6770	7740		
Operating weight	kg	3000	4020	6000	7020	8040		

Note:

- Cooling: chilled water outlet temperature 7°C, water flow=cooling capacity×0.172m³/(h·kW), outdoor ambient temperature 35°C DB; Heating: hot water outlet temperature 45°C, water flow=water flow under cooling mode, outdoor ambient temperature is 7°C DB/6°C WB; Partial heat recovery: hot water inlet/outlet temperature=40°C/55°C, chilled water outlet temperature 7°C, water flow=cooling capacity×0.172m³/(h·kW), outdoor ambient temperature 35°C DB.
- IPLV calculations according to standard performances (in accordance with AHRI 550/590).
- Partial heat recovery is optional, adding this function will affect the weight of the unit and other parameters. Please consult Midea technical personnel for details.
- The built-in hydraulic module is optional. The parameters in the table above (cooling power input, heating power input, rated current, start current, max. operating current) do not include the water pump parameters of the built-in hydraulic module. Please consult Midea technical personnel for details.
- As a result of the continuous improvement of the product, the above parameters may be changed, please refer to the product nameplate and in-kind.

## Cooling only

Model			RCAG100HA	RCAG130HA	RCAG200HA	RCAG230HA	RCAG260HA
Nominal parameter	Cooling capacity	kW	340.0	460.0	680.0	800.0	920.0
	Cooling power input	kW	102.5	138.0	205.0	240.5	276.0
	Cooling COP	W/W	3.317	3.333	3.317	3.326	3.333
	IPLV	W/W	4.813	4.721	4.813	4.759	4.721
	Partial heat recovery*	kW	102.0	138.0	204.0	240.0	276.0
	Compressor	Type	/	Hermetic scroll compressor			
Quantity		System 1	/	2	2	2	2
		System 2	/	1	2	1	2
		System 3	/	-	-	2	2
		System 4	/	-	-	1	2
Energy regulation mode	/	Adaptive energy regulation					
Refrigerant	Type	/	R410A				
	Charge amount	System 1	kg	38	38	38	38
		System 2	kg	18	38	18	18
		System 3	kg	-	-	38	38
		System 4	kg	-	-	18	38
Power supply	/	380V-3Ph-50Hz					
Rated current	A	181.5	244.3	181.5/181.5	181.5/244.3	244.3/244.3	
Start current	A	589.0	673.0	589.0/589.0	589.0/673.0	673.0/673.0	
Max. operating current	A	257.7	343.6	257.7/257.7	257.7/343.6	343.6/343.6	
Air side heat exchanger	Type	/	High efficiency internal thread pipe + hydrophilic aluminum fin				
	No. of fan	/	6	8	12	14	16
	Air flow rate	m³/h	20000×6	20000×8	20000×12	20000×14	20000×16
	Motor power input	kW	1.300×6	1.300×8	1.300×12	1.300×14	1.300×16
Water side heat exchanger	Type	/	Shell and tube				
	Water flow rate	m³/h	58.48	79.12	117.0	137.6	158.2
	Pressure drop	kPa	63.0	63.0	63.0	63.0	63.0
	Water pipe connection	mm	DN125	DN125	DN125/DN125	DN125/DN125	DN125/DN125
	Max. working pressure	kPa	1000				
	Fouling factor	m²·°C/kW	0.018				
Built-in hydraulic module (optional)*	Pump type	/	Single-stage piping centrifugal pump				
	No. of pump	/	1	1	2	2	2
	Pump power input (high lift)	kW	7.5	11	7.5/7.5	7.5/11	11/11
	Pump power input (ultra high lift)	kW	11	15	11/11	11/15	15/15
	External water head (high lift/nominal flow)	kPa	198.0	223.4	198.0/198.0	198.0/223.4	223.4/223.4
	External water head (ultra high lift/nominal flow)	kPa	304.8	309.0	304.8/304.8	304.8/309.0	309.0/309.0
	Expansion tank capacity	L	80	80	80/80	80/80	80/80
	Max. water side pressure (with built-in hydraulic module)	kPa	1000	1000	1000	1000	1000
	Inlet and outlet pipe (with built-in hydraulic module)	mm	DN125	DN125	DN125/DN125	DN125/DN125	DN125/DN125
	Partial heat recovery heat exchanger (optional)*	Type	/	Plate heat exchanger			
Water flow rate		m³/h	5.8	7.9	5.8/5.8	5.8/7.9	7.9/7.9
Pressure drop		kPa	11.3	12.8	11.3/11.3	11.3/12.8	12.8/12.8
Connecting pipe diameter		mm	DN50	DN50	DN50/DN50	DN50/DN50	DN50/DN50
Unit dimensions	Length	mm	3530	4700	7060	8230	9400
	Width	mm	2300	2300	2300	2300	2300
	Height	mm	2500	2500	2500	2500	2500
Unit weight	kg	2900	3870	5800	6770	7740	
Operating weight	kg	3000	4020	6000	7020	8040	

Note:

- Cooling: chilled water outlet temperature 7°C, water flow=cooling capacity×0.172m³/(h·kW), outdoor ambient temperature 35°C DB; Partial heat recovery: hot water inlet/outlet temperature=40°C/55°C, chilled water outlet temperature 7°C, water flow=cooling capacity×0.172m³/(h·kW), outdoor ambient temperature 35°C DB.
- IPLV calculations according to standard performances (in accordance with AHRI 550/590).
- Partial heat recovery is optional, adding this function will affect the weight of the unit and other parameters. Please consult Midea technical personnel for details.
- The built-in hydraulic module is optional. The parameters in the table above (cooling power input, heating power input, rated current, start current, max. operating current) do not include the water pump parameters of the built-in hydraulic module. Please consult Midea technical personnel for details.
- As a result of the continuous improvement of the product, the above parameters may be changed, please refer to the product nameplate and in-kind.

# Dimensions and base diagrams

## Dimensions

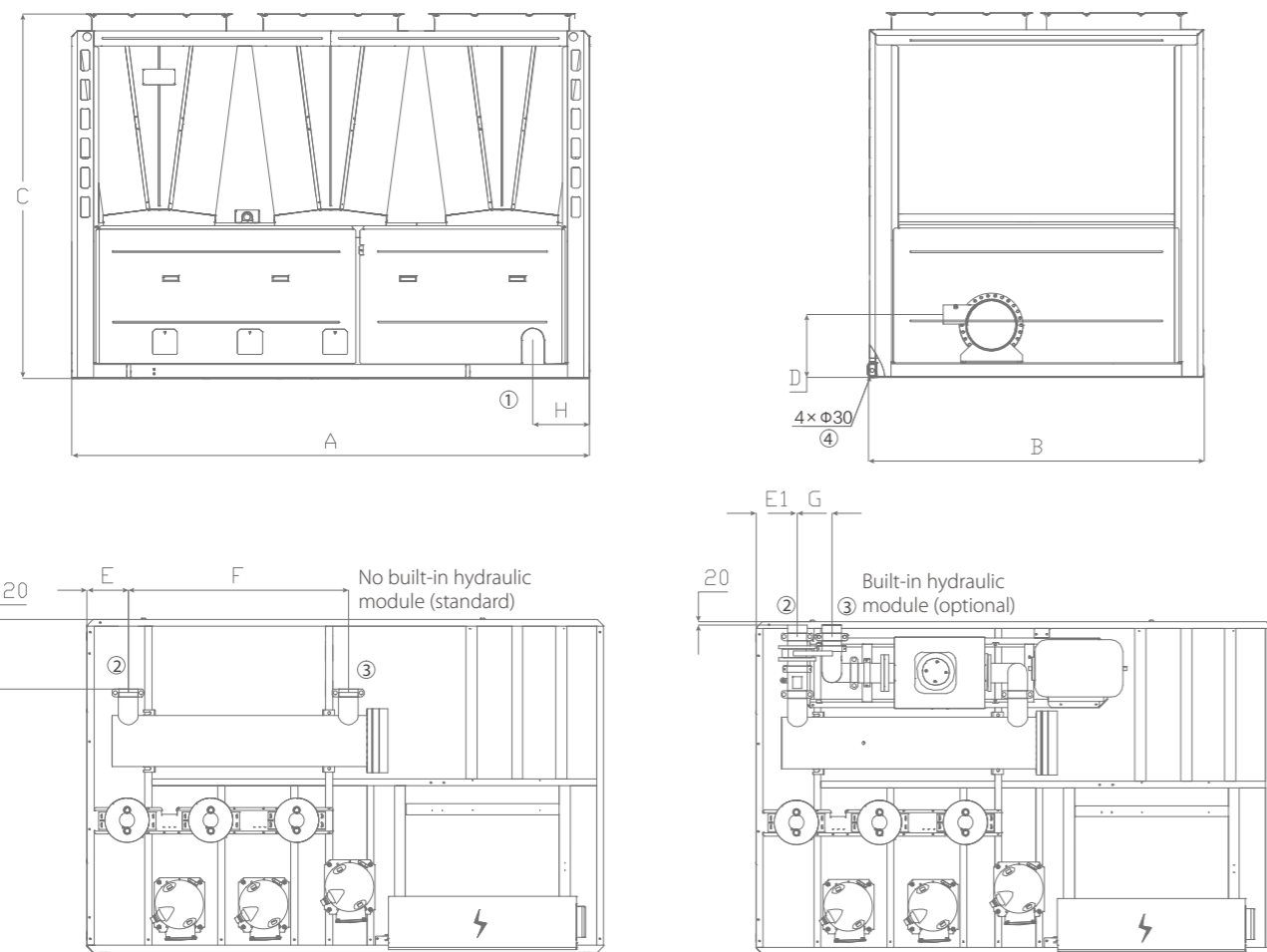

Note: ① Power incoming line ② Chilled water outlet Victaulic connection ③ Chilled water inlet Victaulic connection ④ Lifting point

Model	Dimensions (unit: mm)								
	A	B	C	D	E	E1	F	G	H
RHAG100HA RCAG100HA	3530	2300	2500	430	280	280	1500	235	385
RHAG130HA RCAG130HA	4700	2300	2500	430	1080	420	1730	925	1820

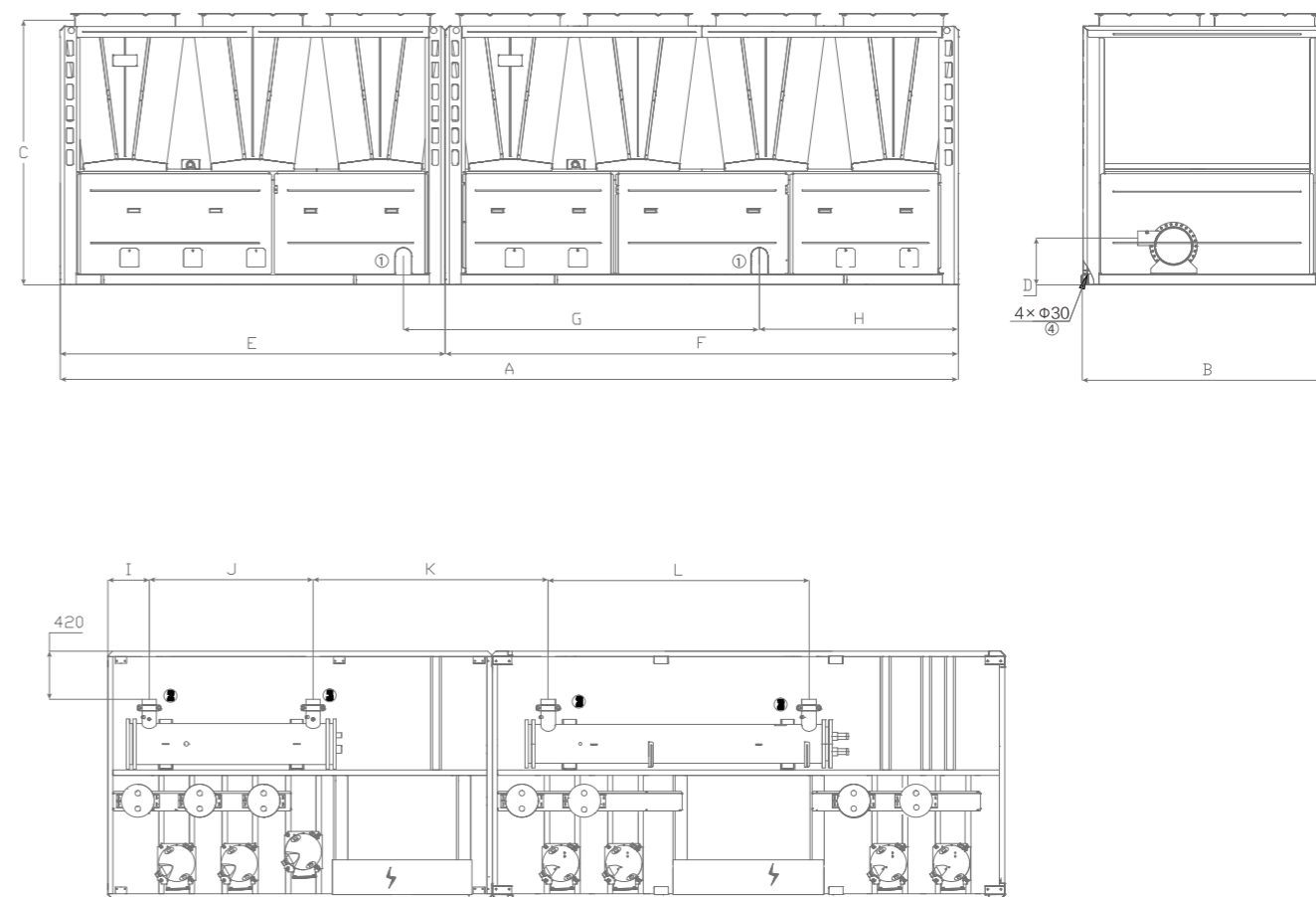

Note: ① Power incoming line ② Chilled water outlet Victaulic connection ③ Chilled water inlet Victaulic connection ④ Lifting point

Model	Dimensions (unit: mm)											
	A	B	C	D	E	F	G	H	I	J	K	L
RHAG200HA RCAG200HA	7060	2300	2500	430	3530	3530	3530	385	280	1500	2030	1500
RHAG230HA RCAG230HA	8230	2300	2500	430	3530	4700	3265	1820	280	1500	2830	1730
RHAG260HA RCAG260HA	9400	2300	2500	430	4700	4700	4700	1820	1080	1730	2970	1730

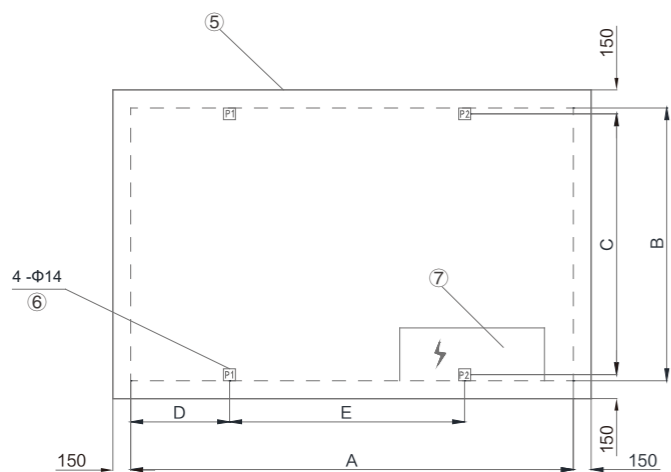

- ⑤ Installation foundation
- ⑥ Spring isolator installation hole
- ⑦ Electric control box

Model	Dimensions (unit: mm)				
	A	B	C	D	E
RHAG100HA RCAG100HA	3530	2300	2220	644	2200

Model	Spring isolator at all points	
	P1	P2
RHAG100HA RCAG100HA	MHD-1050	MHD-1050

Note:  
 1. The spring isolator is optional.  
 2. The value in the spring isolator model indicates the bearable weight (unit: kg). For example, "1050" in "MHD-1050" indicates 1,050kg.

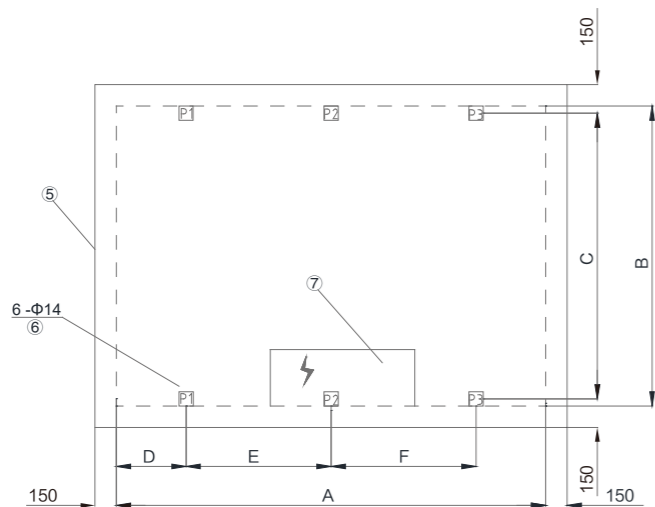

- ⑤ Installation foundation
- ⑥ Spring isolator installation hole
- ⑦ Electric control box

Model	Dimensions (unit: mm)					
	A	B	C	D	E	F
RHAG130HA RCAG130HA	4700	2300	2220	844	1412	1600

Model	Spring isolator at all points		
	P1	P2	P3
RHAG130HA RCAG130HA	MHD-850	MHD-850	MHD-850

Note:  
 1. The spring isolator is optional.  
 2. The value in the spring isolator model indicates the bearable weight (unit: kg). For example, "850" in "MHD-850" indicates 850kg.

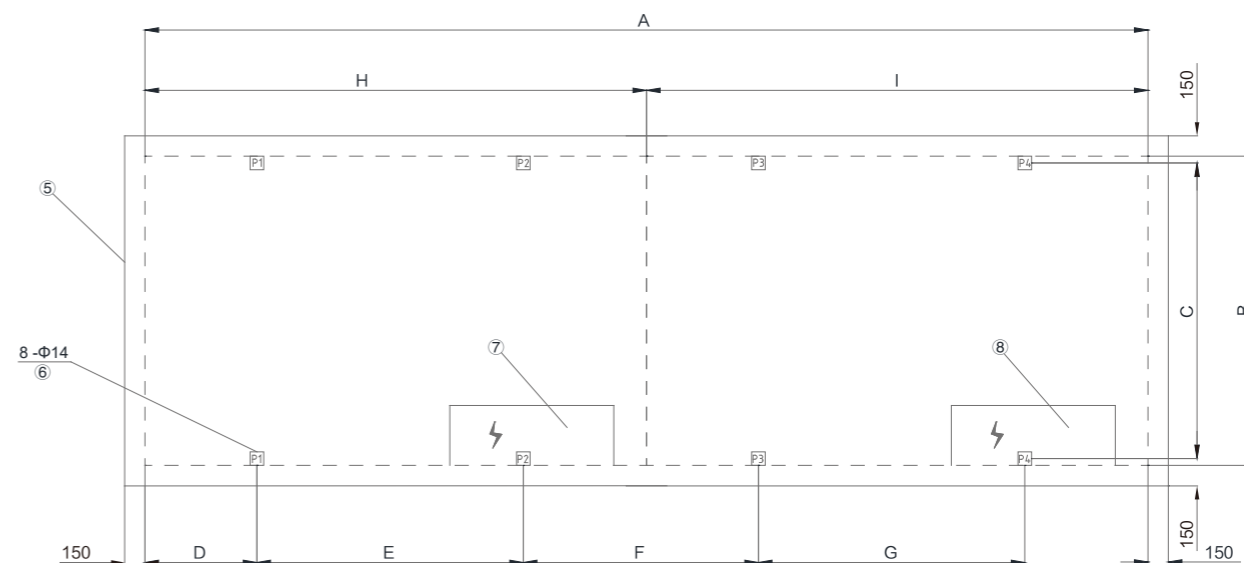

- ⑤ Installation foundation
- ⑥ Spring isolator installation hole
- ⑦ Electric control box
- ⑧ Electric control box

Model	Dimensions (unit: mm)								
	A	B	C	D	E	F	G	H	I
RHAG200HA RCAG200HA	7060	2300	2220	644	2200	1330	2200	3530	3530

Model	Spring isolator at all points			
	P1	P2	P3	P4
RHAG200HA RCAG200HA	MHD-1050	MHD-1050	MHD-1050	MHD-1050

Note:  
 1. The spring isolator is optional.  
 2. The value in the spring isolator model indicates the bearable weight (unit: kg). For example, "1050" in "MHD-1050" indicates 1,050kg.

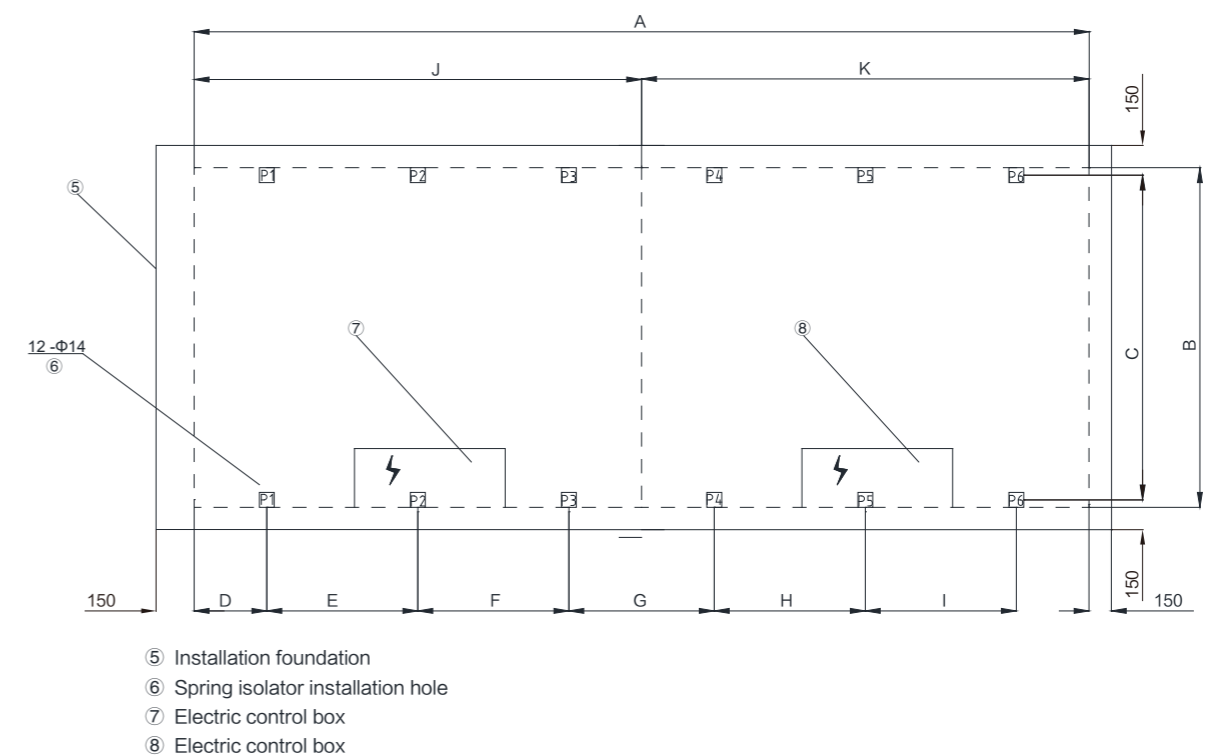
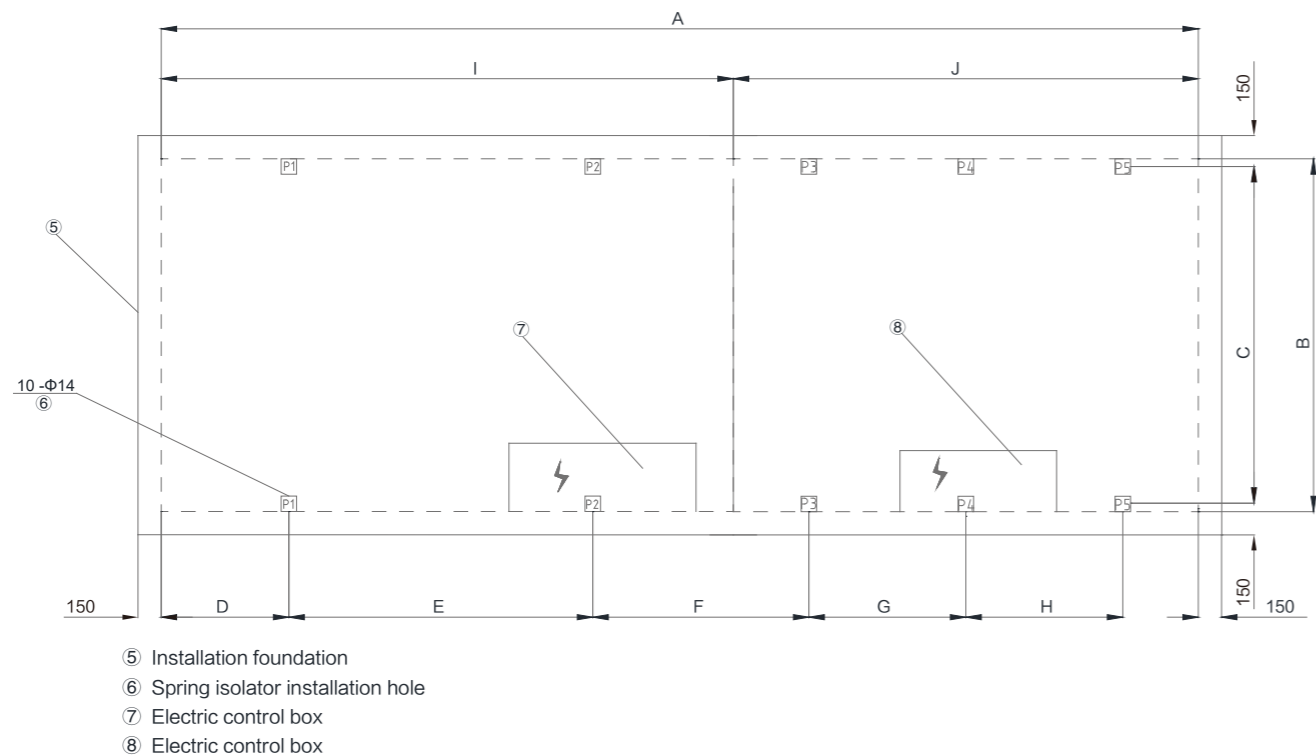

Model	Dimensions (unit: mm)									
	A	B	C	D	E	F	G	H	I	J
RHAG230HA RCAG230HA	8230	2300	2220	644	2200	1530	1412	1600	3530	4700

Model	Spring isolator at all points				
	P1	P2	P3	P4	P5
RHAG230HA RCAG230HA	MHD-1050	MHD-1050	MHD-850	MHD-850	MHD-850

Note:

- The spring isolator is optional.
- The value in the spring isolator model indicates the bearable weight (unit: kg). For example, "1050" in "MHD-1050" indicates 1,050kg.

When several modular units are combined for use, the total water outlet temperature sensor must be added to the general water outlet pipe. The specific operations are as follows: (Remarks: The total water temperature sensor is a unit accessory.)

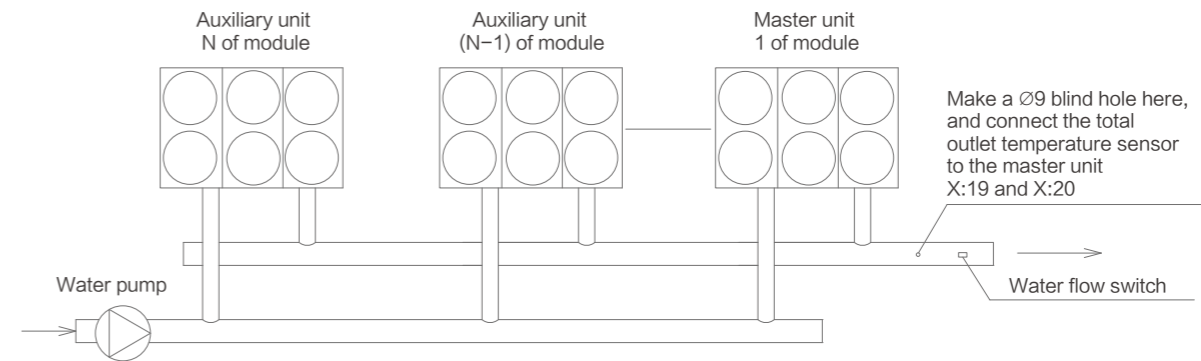

Model	Dimensions (unit: mm)										
	A	B	C	D	E	F	G	H	I	J	K
RHAG260HA RCAG260HA	9400	2300	2220	844	1412	1600	1688	1412	1600	4700	4700

Model	Spring isolator at all points					
	P1	P2	P3	P4	P5	P6
RHAG260HA RCAG260HA	MHD-850	MHD-850	MHD-850	MHD-850	MHD-850	MHD-850

Note:

- The spring isolator is optional.
- The value in the spring isolator model indicates the bearable weight (unit: kg). For example, "850" in "MHD-850" indicates 850kg.

# Options

Items	Standard	Optional
Power supply	380V-3Ph-50Hz	50Hz: 400V, 415V (Cooling only and Heat pump)
Water side pressure	1.0MPa	1.6MPa, 2.0MPa
Anti-corrosion treatment	×	√
Communication	Modbus-RTU (RS485 port)	BACnet IP, BACnet MS/TP (RJ-45 port)
Water pipe connection	Victaulic	Flange
Spring isolator	×	√
Water flow switch	×	√
Insulation	20mm	40mm
Noise reduction box for compressor	×	√
Built-in hydraulic module	×	√
Heat recovery	×	Hot water inlet/outlet temperature 40/55°C
Low ambient temperature cooling	×	-20°C
Low water outlet temperature (cooling)	×	-6°C(with ethylene glycol or propylene glycol)
Remote control panel	×	√
Midea Chiller Plant Control	×	√
Midea Smart Cloud platform	×	√
QuickView	×	√
Wired controller	×	√

Note: For other options, please contact with our engineers.

# Installation and Maintenance

Single installation

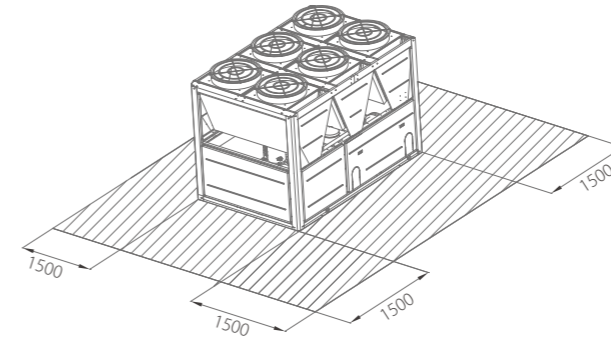

Series connection

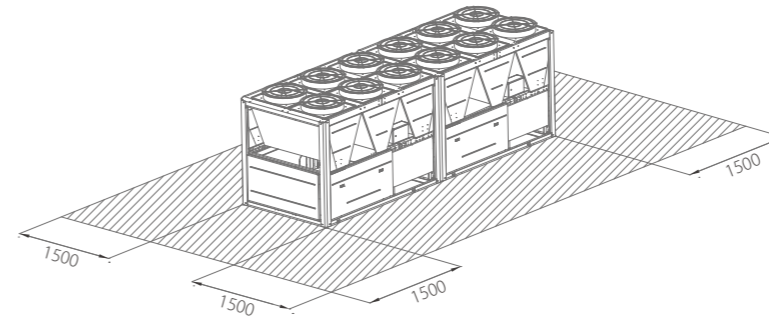

Parallel connection

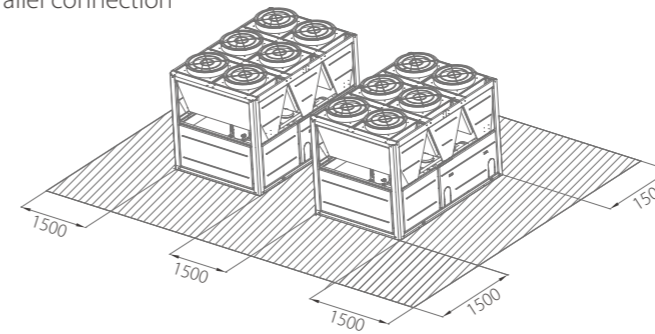

Layout A

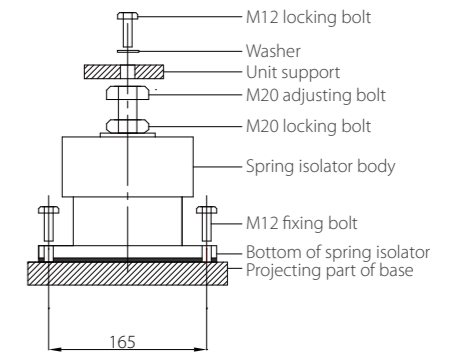

Note: The distance is 165 mm when the optional spring isolator provided by Midea is used.

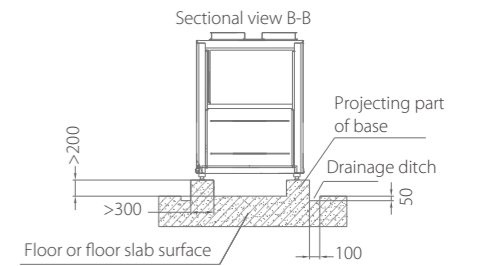
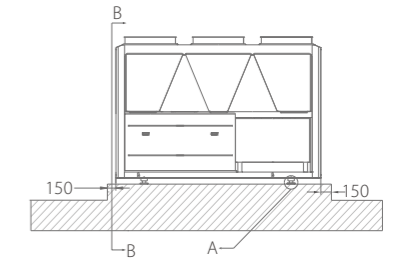

- Notes:
1. The unit should be installed on the base due to vibration, and the base should be strong enough to bear the operating weight of the unit.
  2. When the concrete base is constructed, it is necessary to build drainage ditches around the base to facilitate drainage.
  3. When the unit is installed, a spring isolator is required. See the unit base diagram for the size and location of the spring isolator.
  4. The standard products do not come with ground bolts. Custom-ers may buy and install bolts according to the situation on site. The ground bolts can be installed in the reserved holes, or expansion bolts can be used.

## Special installation spaces

- The unit should be installed at a well-ventilated outdoor location. If it is installed close to a wall, the minimum installation distances are shown below:
- If there are facilities such as a canopy above the unit, the distances from the facilities to the unit top must meet the requirements of the following diagram (without enclosing wall around the unit).
- When the unit needs to be installed under the eaves, the distances must meet the requirements of the following diagram:

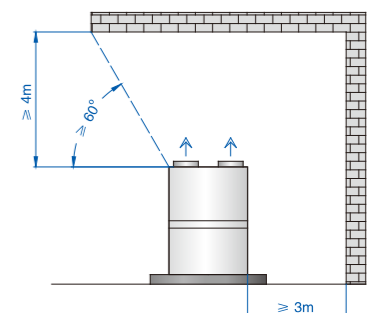
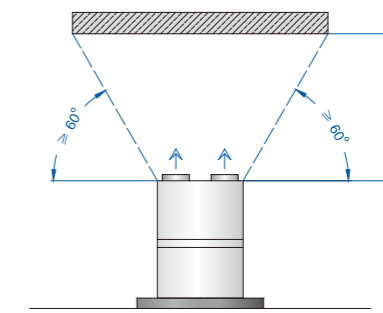
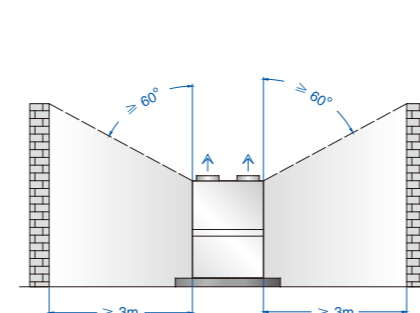

### Effective external pump lift

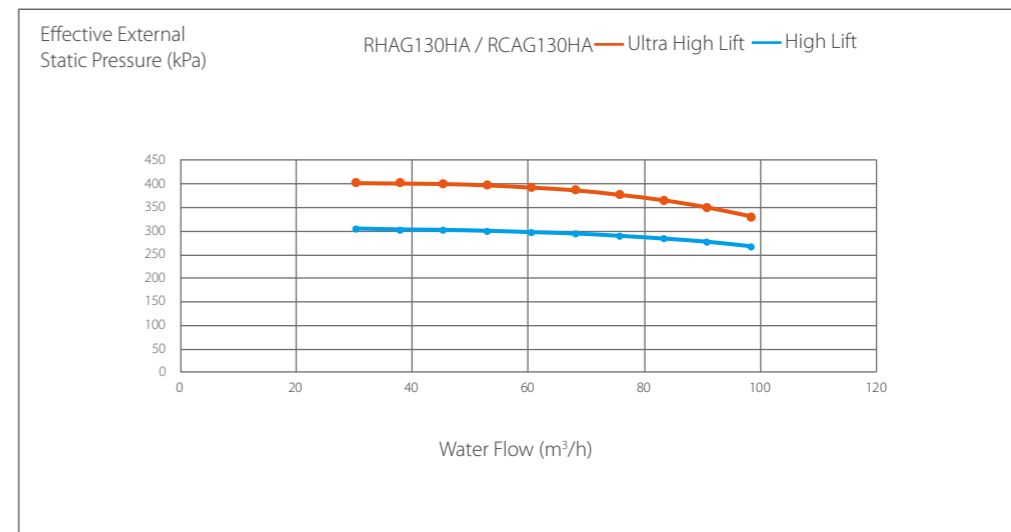
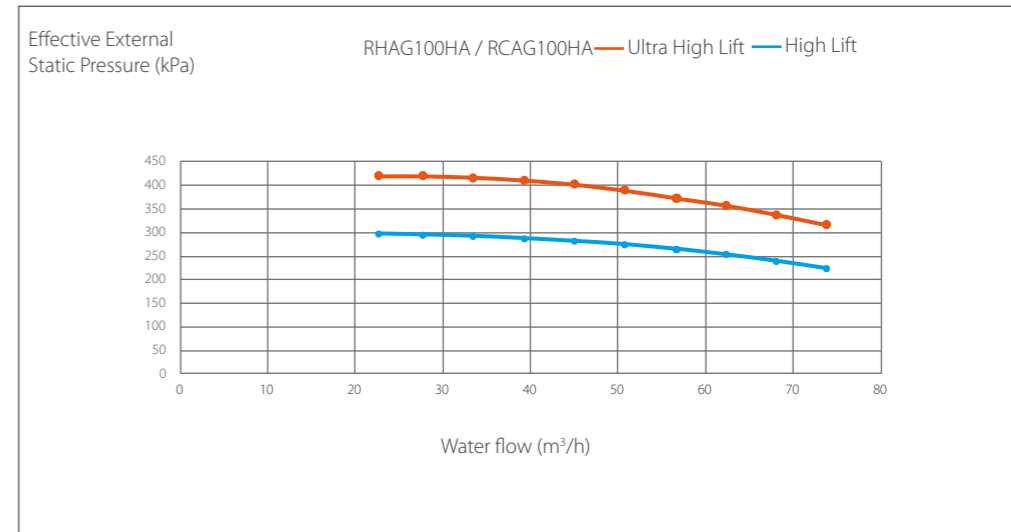

### Built-in hydraulic module

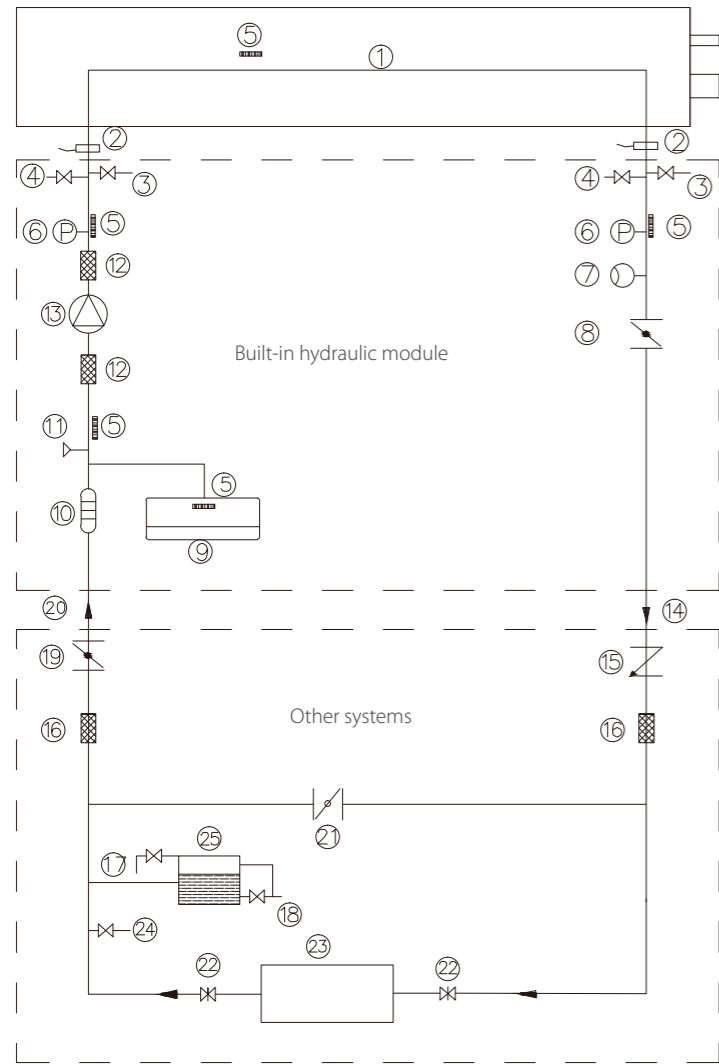

- Built-in hydraulic module Component
1. Shell-and-tube heat exchanger
  2. Water temperature sensor
  3. Drain valve
  4. Air discharge valve
  5. Antifreeze electric heater
  6. Water pressure gauge
  7. Electronic flow switch
  8. Butterfly valve
  9. Expansion tank
  10. Filter (Victaulic fixing)
  11. Safety valve
  12. Rubber soft joint
  13. Water pump

- Flow direction
14. Water outlet of hydraulic module
  20. Water inlet of hydraulic module

- Other system components (Installed by customer)
15. Check valve
  16. Rubber soft joint
  17. Water replenishing valve
  18. Drain valve
  19. Butterfly valve
  21. Bypass valve
  22. Stop valve
  23. Air conditioning terminal
  24. Air discharge valve
  25. Expansion tank

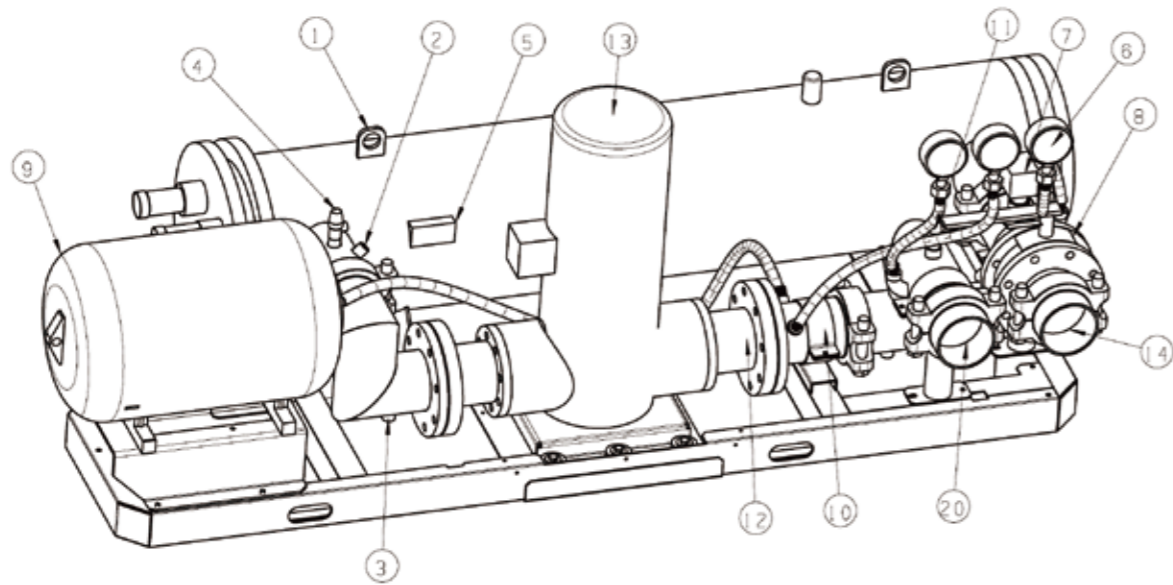

# Intelligent Management

## Midea Chiller Plant Control

Midea Chiller Plant Control is a group control system for commercial air conditioning that includes air conditioners, water pumps, cooling towers, terminals and related ancillary equipment (including valves, sensors etc.) as the underlying control objects. Based on a powerful control logic program and communication network, it establishes a 3-layer control framework that integrates the equipment, control and management layers. Midea Chiller Plant Control contains a unique operation module from Midea that is designed to save energy, so in addition to automated stable operations for the various devices, this product also improves and optimizes user management capabilities, reduces labour costs, boosts operational efficiency and lowers the overall energy consumption for commercial air conditioning.

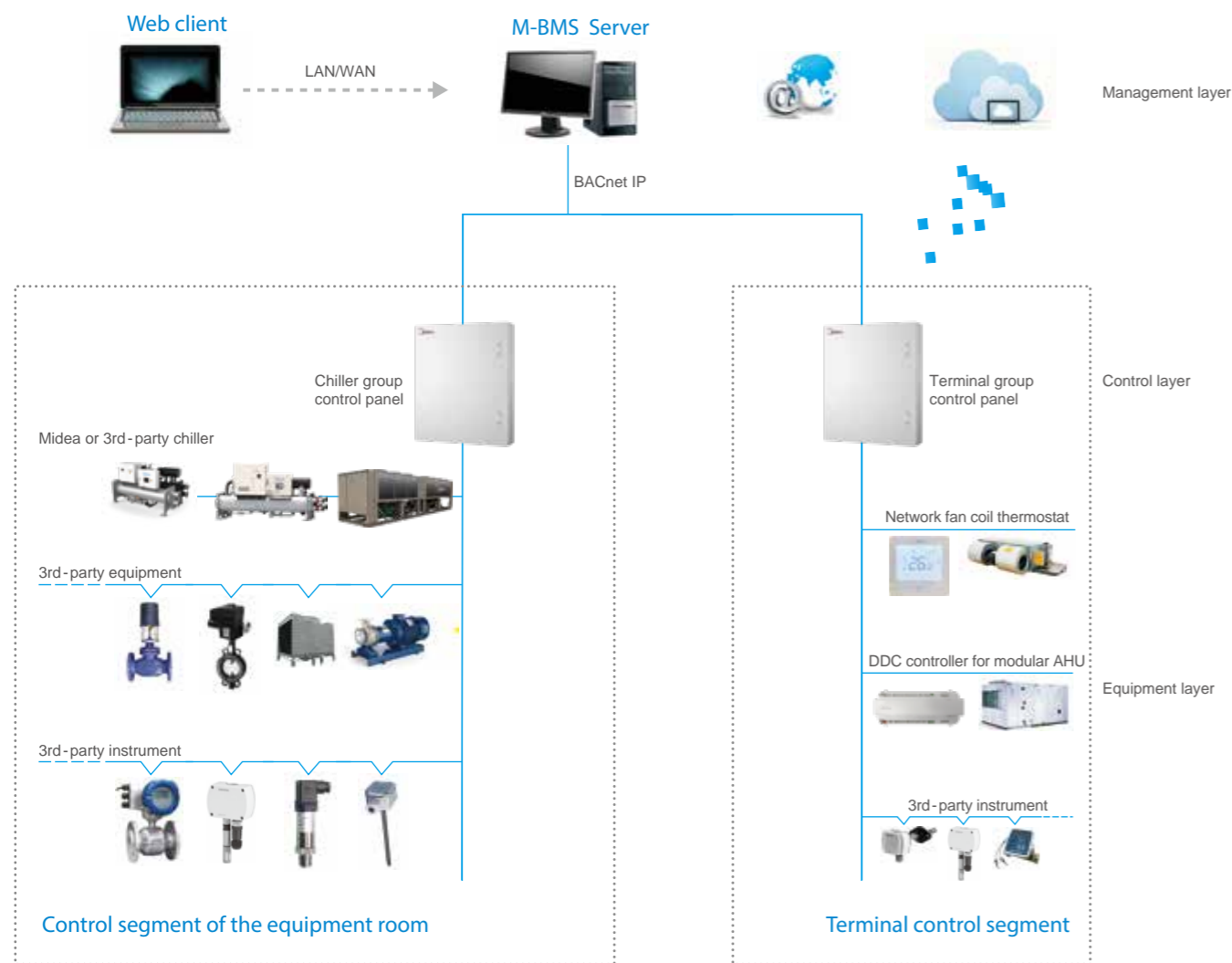

## Midea Smart Cloud platform



Midea has built a flawless internet-based remote monitoring system, which provides customers with outstanding cloud service via advanced cloud service technologies and the internet. Customers can connect Midea air conditioner to the global remote monitoring system through Midea's IMU smart data acquisition terminal, so that professionals can help the customer to implement remote

fault diagnosis, analysis and receive early warning alarms for failures, ensuring the equipment's optimal operation. Customers authorized by Midea can use a Web browser to view the real-time monitoring data of the air conditioning system.

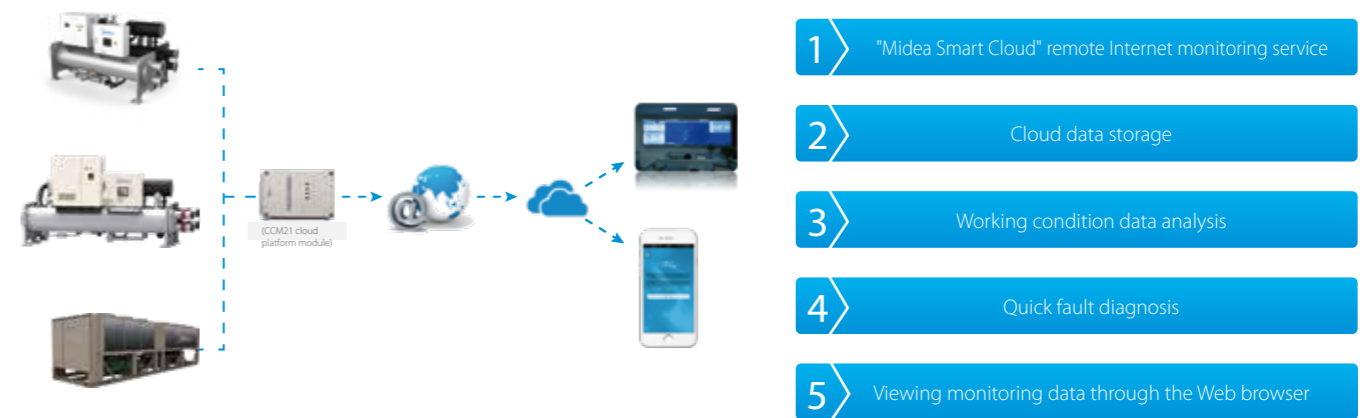

## QuickView

Midea's QuickView smart software control system is a type of smart software specially developed by Midea. It features high real-time efficiency, stability, reliability, a high degree of visualization and strong scalability. It can implement a wide variety of scenarios such as real-time data monitoring of units, unit equipment management, remote control, curve display, data storage, alarm query, fault diagnosis, uploading data to the cloud and external data analysis, greatly improving the unit's operation management efficiency and reducing the human input and operation and maintenance costs.

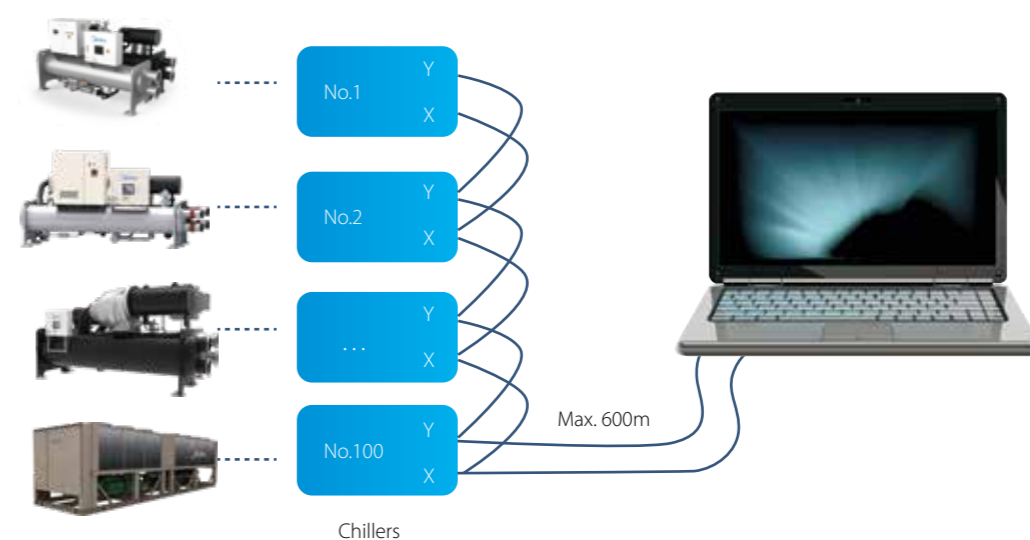

# Reference Projects



## Energy Station of Hubin New District, Suqian

- 🌐 Country: China
- 📍 City: Suqian
- 🏢 Outdoor Units: Air cooled scroll chiller
- 📊 Total Capacity: 1,375 RT



## Guiyang International Trade Mart

- 🌐 Country: China
- 📍 City: Guiyang
- 🏢 Outdoor Units: Air cooled scroll chiller
- 📊 Total Capacity: 1,820 RT



### Shijiazhuang Fifteenth High School

- 🌐 Country: China
- 📍 City: Shijiazhuang
- 🏠 Outdoor Units: Air cooled scroll chiller
- 📊 Total Capacity: 2,125 RT



### NTP Novi Sad Scientific and Technological Centre

- 🌐 Country: Serbia
- 📍 City: Novi Sad
- 🏠 Outdoor Units: Air cooled scroll chiller
- 📊 Total Capacity: 600 RT



### White Sails Batumi

- 🌐 Country: Georgia
- 📍 City: Batumi
- 🏠 Outdoor Units: Air cooled scroll chiller
- 📊 Total Capacity: 855 RT

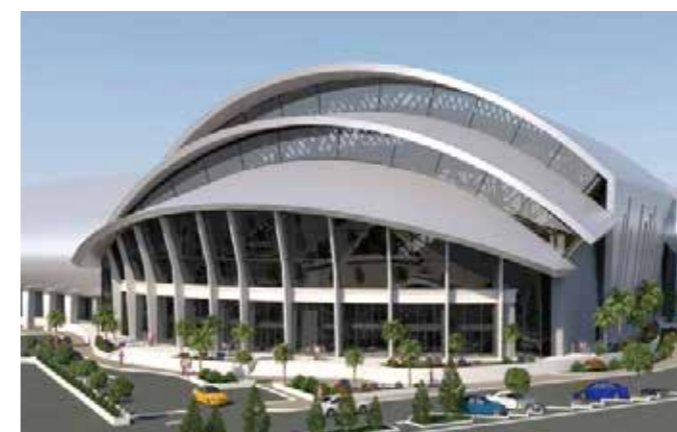

### Guiyang International Trade Mart

- 🌐 Country: Georgia
- 📍 City: Batumi
- 🏠 Outdoor Units: Air cooled scroll chiller
- 📊 Total Capacity: 1,000 RT



### Jerarsi Hospital

- 🌐 Country: Georgia
- 📍 City: Tbilisi
- 🏠 Outdoor Units: Air cooled scroll chiller
- 📊 Total Capacity: 750 RT