

# V8

## Indoor Unit

SMART IN ONE

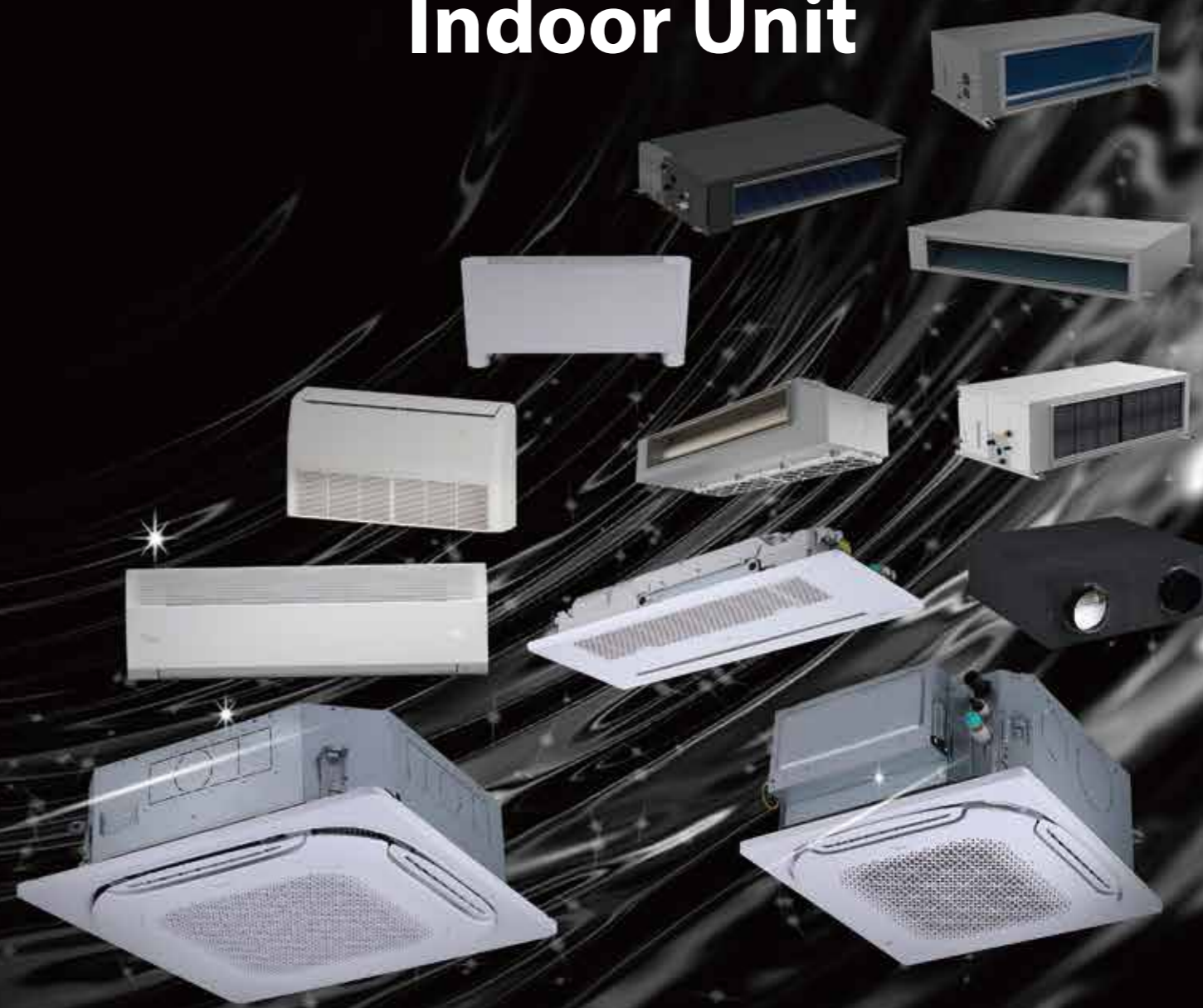

Midea Building Technologies Division

Midea Group

Add.: Midea Headquarters Building, 6 Midea Avenue, Shunde, Foshan, Guangdong, China

Postal code: 528311

mbt.midea.com    www.midea-group.com    ics.midea.com

Midea reserves the right to change the specifications of the product, and to withdraw or replace products without prior notification or public announcement. Midea is constantly developing and improving its products.



2024

# Midea MBT

Midea MBT (Midea Building Technologies) is a key division of the Midea Group, a leading provider of comprehensive solutions for intelligent buildings. It specializes in energy sources, elevators, control systems, and heating, ventilation & air conditioning. Midea MBT continues the tradition of innovation upon which it was founded and has emerged as a global leader in the HVAC and building management industry. A strong drive for advancement has resulted in an extensive R&D department that has placed Midea MBT at the forefront of the competition. Through independent projects and joint-cooperation with other global enterprises, Midea has supplied thousands of innovative solutions to customers worldwide.



## 4 production bases can achieve fast delivery



## Over 100 testing labs cover a wide range of real application scenarios

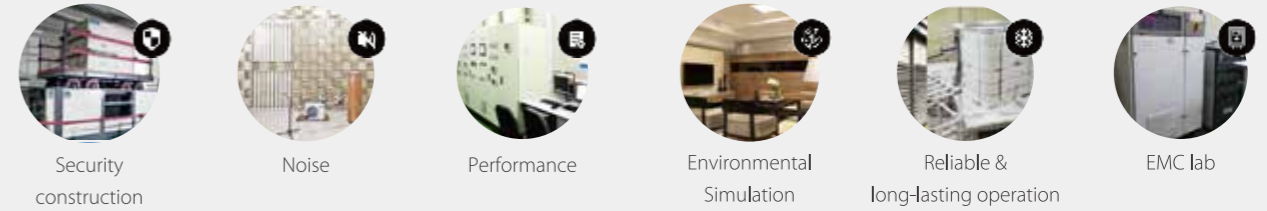

## All products can be visualized and digitalized throughout entire process



## 3 businesses make up the core of Midea intelligent building solutions



# APPLICATION SOLUTIONS

## Office Complexes

### Enjoy comfort while working

Midea VRF provides solutions for office buildings of all sizes and its smart control solutions streamline the management of VRF. It offers a wide variety of indoor units that are suitable for all designs.

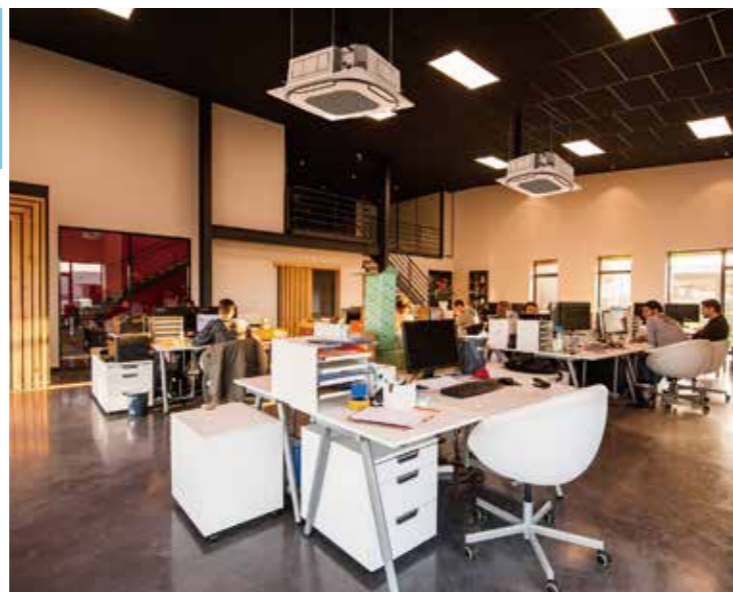

## Hotels & Shopping Malls

### Increase your business, not your bills

The high efficiency and reliability of Midea VRF make it the ideal choice for commercial applications. Intelligent control solutions like hotel key cards and touch screen controllers make management easy.



## Residential Apartments

### One for every home

A compact size and high efficiency make Midea VRF suitable for all residential homes.



## Hospitals/ Schools/ Airports

### Meeting all expectations

The innovative design and variety of indoor unit options make Midea VRF suitable for all kinds of applications. The newly designed puro-air kit is perfect for modern hospitals.

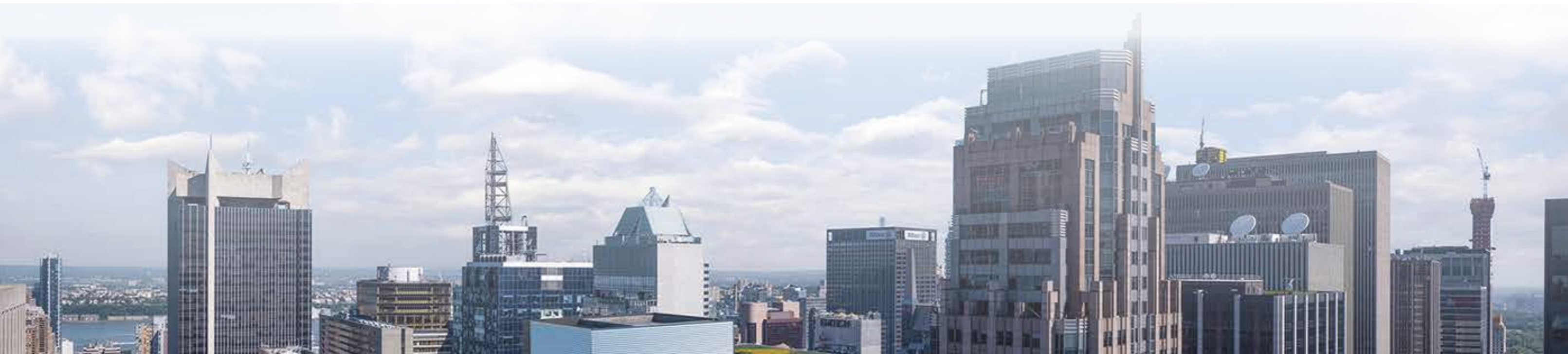

## International Service Management (ICS)

ICS is a platform for customers to seek professional technical support. Through ICS, you can inquire about product information, documentation, spare parts and troubleshooting, ask technical questions, submit complaints, and order spare parts.

<https://ics.midea.com>



### My order

Inquire about spare parts from an exploded view and place orders for spare parts directly in ICS.

### Document inquiry and download

View or download product technical documentation online, such as catalogs, images, training PPTs, etc.

### Technical inquiry & FAQ

Ask technical questions online and receive a prompt response from our technicians. Or find a quick solution in the FAQ.

### Troubleshooting

Query the error code and solution by SN, model name, error code or product type.

### Complain

Submit product quality complaints online, and our after-sales engineers will respond promptly.



## Mobile Intelligence Service App (MISA)

MISA is the mobile terminal of ICS, with the same functions as ICS. The mobile service improves the response time and convenience of technical support.

<https://link.midea.com>



Technical Enquiry



Troubleshooting

Download

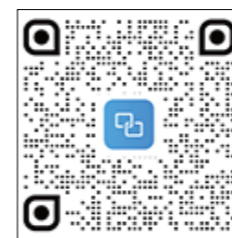

Scan to download the mobile app



FAQ



Complain



Search product manuals



Spare parts list

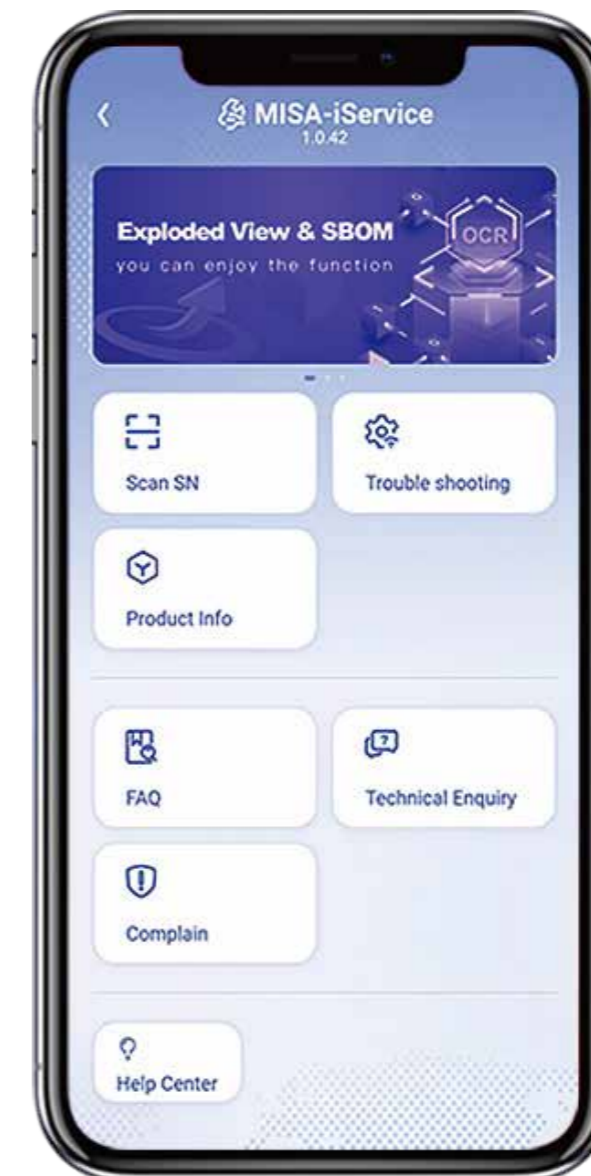

Feedback



Thank you for your attention and feedback



## Indoor Unit

One-Way Cassette

Two-Way Cassette

Compact Four-Way Cassette

Four-Way Cassette

Arc Duct

Medium Static Pressure Duct

High Static Pressure Duct

Wall Mounted

Floor Standing

Ceiling&Floor

Fresh Air Processing

Small Airflow Rate Fresh Air Processing

HRV

## Indoor Unit Lineup

### ■ One-Way Cassette



- Automatic anti-condensation
- Multiple Steps Vertical Swing
- Built-in 1200mm high-lift drain pump(Digital feedback DC water pump)

### ■ Arc Duct



- 199mm ultra-thin height (all models)
- 450mm ultra-narrow depth (all models)
- Static pressure adaption, constant air volume supply
- Built-in 1200mm high-lift drain pump
- Optional medium efficiency filter
- Optional Positive and Negative Ion Sterilization Module

### ■ Two-Way Cassette



- Automatic anti-condensation
- Multiple Steps Vertical Swing
- Built-in 1200mm high-lift drain pump(Digital feedback DC water pump)

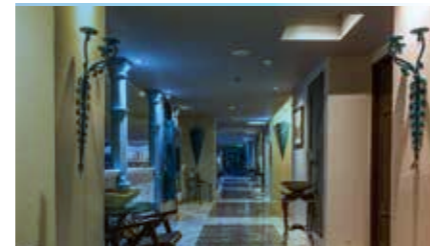

### ■ Medium Static Pressure Duct

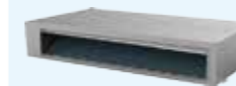

- ESP up to 160Pa (all models)
- 245mm ultra-thin height (all models)
- Static pressure adaption, constant air volume supply
- Built-in 1200mm high-lift drain pump
- Optional HEPA filter with H12 rating
- Optional medium to high efficiency filter
- Optional Positive and Negative Ion Sterilization Module



### ■ Compact Four-Way Cassette

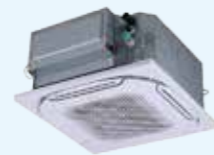

- 575mm compact body size
- 360° airflow
- Individual louver control
- 3.5m high ceiling installation
- Built-in 1200mm high-lift drain pump
- Optional medium efficiency filter

### ■ High Static Pressure Duct



- 5.6kW-16kW ESP up to 250Pa
- 20kW-56kW ESP up to 400Pa
- 299mm ultra-thin height (5.6kW-16kW)
- Static pressure adaption, constant air volume supply
- Built-in 1200mm high-lift drain pump
- Optional HEPA filter with H13 rating
- Optional medium to high efficiency filter

### ■ Four-Way Cassette



- 360° airflow, uniform air flow and temperature distribution
- Individual louver control
- Built-in 1200mm high-lift drain pump



### ■ Wall Mounted



- Supports installation close to the ceiling to free up space
- Bi-directional Coanda airflow, enhanced comfort
- Quiet operation
- Optional built-in 1200mm high-lift drain pump

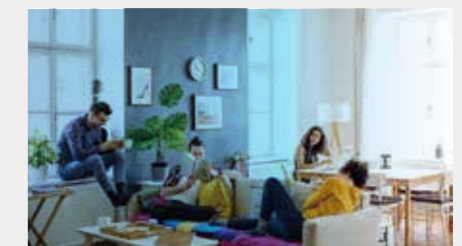

## ■ Floor Standing



- ESP up to 60Pa(F3 concealed model)
- Three appearance options to meet different installation requirement
- DC fan creates a more quiet and comfortable environment
- 0.5°C/1°C Setting Temperature Adjustment

## ■ Ceiling&Floor



- A sleek design suits installation either on the ceiling or floor
- DC fan motor creates a more quiet and comfortable environment
- Optional 600mm high-lift drain pump (When the unit is installed on the ceiling)



## ■ Fresh Air Processing



- 20kW-56kW ESP up to 400Pa
- 550mm ultra-thin height (20kW-56kW)
- Static pressure adaption, constant air volume supply
- Built-in 1200mm high-lift drain pump

## ■ Small Airflow Rate Fresh Air Processing



- 9kW-28kW ESP up to 300Pa
- 310mm ultra-thin height (9kW-28kW) Static pressure adaption, constant air volume supply
- Built-in 1200mm high-lift drain pump

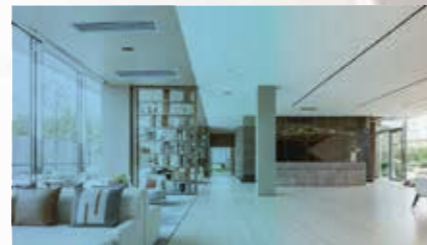

## ■ HRV



- Multiple operation modes: Auto, Bypass, Heat recovery, Free cooling mode.
- Optional CO<sub>2</sub> Sensor
- Optional Multi-functional Expansion Board

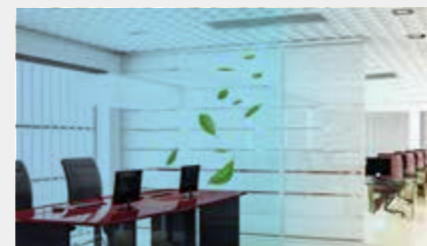



# Indoor Unit Functions

		Functions ●: equipped as standard; ○: customization option; ×: without this function			One-Way Cassette	Two-Way Cassette	Ceiling&Floor		Compact Four-Way Cassette	Four-Way Cassette	Arc Duct	Medium Static Pressure Duct	High Static Pressure Duct	Wall Mounted	Floor Standing	Fresh Air Processing	Small Airflow Rate Fresh Air Processing	
COMFORT & HEALTH	Quiet operation	All indoor units are quiet operation	●	●	●			●	●	●	●	●	●	●	●	×	×	
	Auto cooling-heating changeover	Automatically selects cooling or heating mode to achieve the set temperature	●	●	●			●	●	●	●	●	●	●	●	●	●	
	Cold air prevention	When starting to warm up, the fan speed is automatically adjusted according to coil temperature to prevent cold air discharge After warming up, fan speed is set as desired	●	●	●			●	●	●	●	●	●	●	●	●	●	
	Digital display on/off	Indoor unit displays can be shut off at night, creating a better environment for rest	●	●	●			●	●	●	●	●	●	●	●	●	●	
	Buzzer sound on/off	The buzzer sound of the indoor unit can be turned off to create a quieter environment	●	●	●			●	●	●	●	●	●	●	●	●	●	
	EEV automatic adjustment	When in heating standby mode, the indoor unit automatically adjusts the EEV opening according to the load to eliminate noise of refrigerant flowing.	●	●	●			●	●	●	●	●	●	●	●	●	●	
	Indoor temperature detection control	The indoor temperature of multiple indoor units is obtained from a designated indoor unit, and multiple indoor units in a large space are controlled uniformly through this designated indoor unit.	●	●	●			●	●	●	●	●	●	●	●	×	×	
	0.5°C/1°C setting temperature adjustment	Set temperature can be adjusted in 0.5°C or 1°C steps, enabling precise comfort control	●	●	●			●	●	●	●	●	●	●	●	●	●	
	Home leave mode	During absence, the indoor temperature can be maintained at a certain level	●	●	●			●	●	●	●	●	●	●	●	●	×	×
	Independent power supply	This feature allows the shutdown of some indoor units without shutting down the whole VRF system	●	●	●			●	●	●	●	●	●	●	●	●	●	
	Sleep mode	The smart sleep mode can realize sleep is not easy to catch a cold and wake up refreshing	●	●	●			●	●	●	●	●	●	●	●	●	×	×
	Mildew proof of heat exchanger	After the unit is shutdown, the fan is delayed shutdown to dry the heat exchanger and prevent the heat exchanger from mildew	●	●	●			●	●	●	●	●	●	●	●	●	×	×
	Air filter	Removes airborne dust particles to ensure a steady supply of clean air	pre-filter ●	pre-filter ●	pre-filter ●				G1 ● G3 ○ F6 ○	G1 ●	G1 ● F6 ○	G1 ● G3+F7○ G3+H12 ○	pre-filter ● F7 ○ H13○	pre-filter ●	G1 ●	pre-filter ● F7 ○ H13○	pre-filter ● F7 ○ H13○	
	Fresh air intake	A reserved outside air intake port allows outdoor air to be introduced directly into the unit	4.5-7.1kW●	●	●				●	●	●	●	×	×	×	●	●	
	Visualization of dirty blockage rate	Dirty blockage rate can be accurately identified and displayed on the controller	×	×	×				×	×	●	●	●	×	×	●	●	
	Silver Ions drain pan	Slow-released nano-silver ions can keep the drain pan free of mold for a long time.	×	×	×				○	○	○	○	○	○	○	×	○	○
	Heat exchanger self-cleaning*	Wash the dirt on the heat exchanger through freezing frost, and then high temperature sterilization.	●	●	●				●	●	●	●	●	●	●	●	×	×
	Humidity control	Additional humidity sensor can achieve humidity control in 35~75%	×	×	○				○	○	○	○	○	○	○	○	×	×
Puro-air kit	Powered by OSRAM's UVC lamps, can effectively kill bacteria, viruses and odors of indoor air	×	×	×				×	×	×	○	○	×	×	○	○		
Sterilization device	Positive and Negative Ion Sterilization Module can effectively kill bacteria, viruses and odors of indoor air	×	×	×				×	×	○	○	×	×	×	×	×		
AIR FLOW	Vertical swing	Possibility to select automatic vertical moving of the air discharge louvre, for uniform air flow and temperature distribution	5 steps + auto	5 steps + auto	5 steps + auto			5 steps + auto	5 steps + auto	×	×	×	5 steps + auto	×	×	×	×	
	Horizontal swing	Possibility to select automatic horizontal moving of the air discharge louvre, for uniform air flow and temperature distribution	×	×	●			×	×	×	×	×	○	×	×	×	×	
	Fan speed steps	Multiple fan speeds can be selected to optimize comfort levels	7 steps	7 steps	7 steps			7 steps	7 steps	7 steps	7 steps	7 steps	7 steps	7 steps	7 steps	7 steps	7 steps	
	Auto fan speed	Automatically controls rotation speed of fan depending on indoor load to achieve efficiency and comfort simultaneously	●	●	●			●	●	●	●	●	●	●	●	×	×	
	Individual louver control	Individual louver control via the wired remote controller makes it simple to fix the position of each flap individually	×	×	×			●	●	×	×	×	×	×	×	×	×	
	Soft wind mode	Supplies air against the ceiling to create windless environment	●	●	●			●	●	×	×	×	×	●	×	×	×	
	Adaptive ESP	ESP adapts to duct resistance to ensure constant airflow	×	×	×			×	×	●	●	●	●	×	×	●	●	

\* Heat exchanger self-cleaning function can be available only when V8 Mini is connected. There is no AHU-Kit and 2<sup>nd</sup> generation indoor units in the system.

# Indoor Unit Functions

Functions ●: equipped as standard; ○: customization option ; ×: without this function			One-Way Cassette	Two-Way Cassette	Ceiling&Floor	Compact Four-Way Cassette	Four-Way Cassette	Arc Duct	Medium Static Pressure Duct	High Static Pressure Duct	Wall Mounted	Floor Standing	Fresh Air Processing	Small Airflow Rate Fresh Air Processing
ENERGY SAVING	META mode	Triple variable control maximizes energy saving operation	●	●	●	●	●	●	●	●	●	●	×	×
	ECO mode	The set temperature will automatically increase by 1°C per hour (in cooling mode) or decrease by 1°C per hour (in heating mode), with a maximum change of 2°C.	●	●	●	●	●	●	●	●	●	●	×	×
	Full DC electronic components	The fan motor and water pump are DC power supply	●	●	●	●	●	●	●	●	●	●	●	●
	Human Detect Sensor	Using millimeter-wave radar sensor controller automatically turns indoor units on or off upon detecting that the room is occupied or unoccupied, ensuring climate control whilst minimizing energy consumption.	×	×	×	○	○	○ <sup>(1)</sup>	○ <sup>(1)</sup>	○ <sup>(1)</sup>	○	×	×	×
EASY Installation & Service	Program upgrade <sup>(2)</sup>	All indoor units can be upgraded on outdoor unit of the same system, more easy program upgrade.	●	●	●	●	●	●	●	●	●	●	●	●
	Long distance air delivery	Provides adequate airflow and capacity under high ceiling conditions	×	×	×	● 3.5m	● 3m ○ 4.5m	×	×	×	×	×	×	×
	High-lift drain pump	Facilitates condensation draining from the indoor unit	●	●	○ <sup>(3)</sup>	●	●	●	●	●	○	×	●	●
	Water level switch	When the drain pipe is blocked or the drain pipe is poor, the water level switch is turned off, and there is no need to worry about overflowing the ceiling.	●	●	○	●	●	●	●	●	○	×	●	●
	Ceiling anti-dirt setting	The air discharge is specially designed to prevent air blowing against the ceiling to prevent ceiling dirty	●	●	×	●	●	×	×	×	×	×	×	×
	Air baffle fittings for irregular rooms	Some air discharge ports can be blocked with air baffle to optimize air distribution in irregular shaped rooms	×	×	×	●	●	×	×	×	×	×	×	×
	2-core non-polarity communication wiring	Simplifies installation and reduces wiring failures	●	●	●	●	●	●	●	●	●	●	●	●
	Long communication wiring	Communication wiring up to 1200m makes installation more flexible	●	●	●	●	●	●	●	●	●	●	●	●
	3 digit 7-segment display	3 digit 7-segment display can display more parameters and error information	●	●	●	●	●	●	●	●	●	●	●	●
	Error codes are further refined	Simplifies maintenance by refined error code	●	●	●	●	●	●	●	●	●	●	●	●
EASY CONTROL	Timer	Timer can be set to start and stop operation anytime on a daily or weekly basis	●	●	●	●	●	●	●	●	●	●	●	●
	Infrared remote control	Infrared remote control with LCD to remotely control your indoor unit	●	●	●	●	●	●	●	●	●	●	●	●
	Wired remote control	Wired remote control to remotely control your indoor unit	●	●	●	●	●	●	●	●	●	●	●	●
	Group control	Up to 16 indoor units can be in a group control system	●	●	●	●	●	●	●	●	●	●	●	●
	Centralized control	Centralized control to control several indoor units from one single point	●	●	●	●	●	●	●	●	●	●	●	●
	Auto-restart	The unit restarts automatically at the original settings after power failure	●	●	●	●	●	●	●	●	●	●	●	●
	°C/°F setting	Temperature unit °C or °F can be set according to your usage habits	●	●	●	●	●	●	●	●	●	●	●	●
	Long-distance on/off function	Long-distance startup or shutoff the system by weak electricity external devices	●	●	●	●	●	●	●	●	●	●	●	●
EXTENDED FUNCTIONS	Humidifier connection	Additional expansion board can achieve third-party humidifier connection	×	×	○	○	○	○	○	○	○	○	×	×
	Dehumidifier connection	Additional expansion board can achieve third-party dehumidifier connection	×	×	○	○	○	○	○	○	○	○	×	×
	Electric heater connection	Additional expansion board can achieve third-party electric heater connection	○ <sup>(4)</sup>	×	○	○	○	○	○	○	○	○	○	○
	Refrigerant leak sensor connection	Additional expansion board can achieve refrigerant leak sensor connection	○ <sup>(4)</sup>	×	○	○	○	○	○	○	○	○	○	○
	CO2 sensor connection	Additional expansion board can achieve CO2 sensor connection	○ <sup>(4)</sup>	×	○	○	○	○	○	○	○	○	○	○
	PM2.5 sensor connection	Additional expansion board can achieve PM2.5 sensor connection	○ <sup>(4)</sup>	×	○	○	○	○	○	○	○	○	○	○
	Third-party controller connection	Third party controller can realize mode, fan speed and temperature control	○ <sup>(4)</sup>	×	○	○	○	○	○	○	○	○	○	○
	Long-distance on/off function	Long-distance startup or shutoff the system by strong electricity external devices	○ <sup>(4)</sup>	×	○	○	○	○	○	○	○	○	○	○
	Long-distance alarm function	Long-distance alarm when an error occurs	○ <sup>(4)</sup>	×	○	○	○	○	○	○	○	○	○	○
	Multiple protections	Multiple protections make the unit run more reliably	●	●	●	●	●	●	●	●	●	●	●	●

Note:

- (1). Use the display box which is equipped with a human detect sensor.
- (2). The program upgrade function needs to be implemented through Bluetooth Module or Data Cloud Gateway. The Bluetooth Module and Data Cloud Gateway needs to be purchased separately.
- (3). Only when the unit is installed on the ceiling.
- (4). To achieve these functions for the One-Way Cassette unit, you need to purchase function expansion modules and install them locally.

# HyperLink



2000M

Communication distance up to

## Independent Power Supply

Some indoor units shut down without shutting down the whole VRF system.

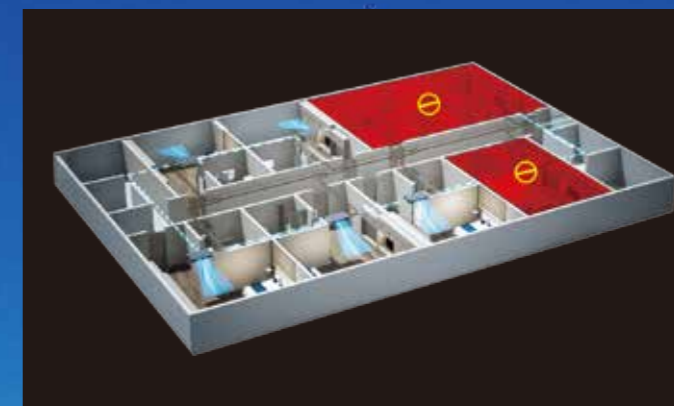

## Any Topology Communication

The communication wire supports tree connection, star connection, ring connection and so on.



## Super Anti-interference Capability

Special waveform restoration technology enhances anti-interference performance for more stable communication.

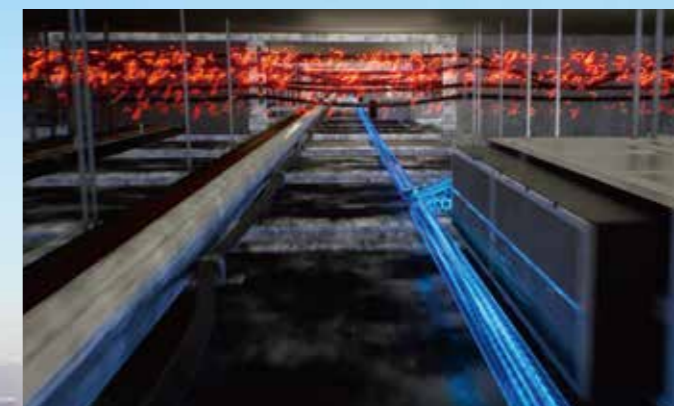



Frosting

Frost makes the surface of heat exchanger dirt stripping



Defrosting

Water flow flushes dirt from heat exchanger



Drying

55°C high temperature drying water, effective sterilization



# HEAT EXCHANGER SELF-CLEANING\*

\* Heat exchanger self-cleaning function can be available only when V8 Mini is connected.



# Full DC Electronic Components

The fan motor and water pump are DC power supply, making the temperature control more precise and the indoor temperature more uniform.

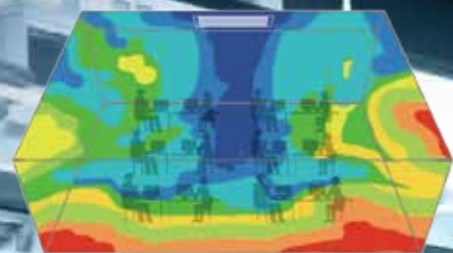

Efficiency %

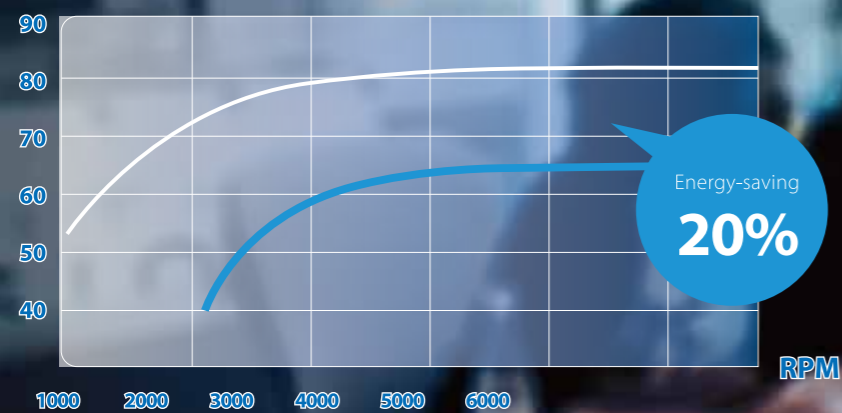

Energy-saving  
**20%**

RPM

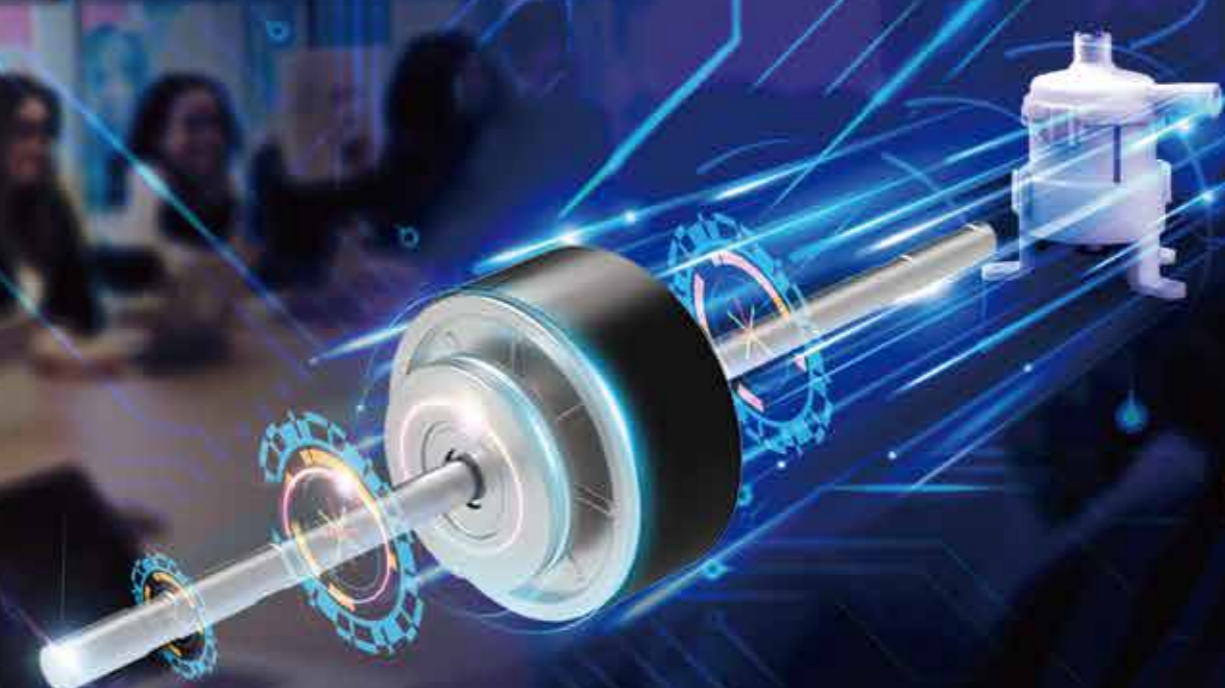

# Optional Multi-Functional Expansion Board



Humidity control



Electric heater connection



Multiple protections



Long-distance on/off function



Long-distance alarm function



Humidifier/Dehumidifier connection



Third-party controller connection



CO2 sensor connection



PM2.5 sensor connection



Refrigerant leak sensor connection

**Switch Module**  
(Optional)

**Expansion Board**  
(Optional)



Free drainage



Quiet operation



High-lift drain pump



## One-Way Cassette



## COMFORT

### Digital Display On/Off

Indoor unit displays can be shut off at night, creating a better environment for rest.



### Buzzer Sound On/Off

Indoor unit buzzer sound can be set off to not disturb the user, creating a quieter environment.

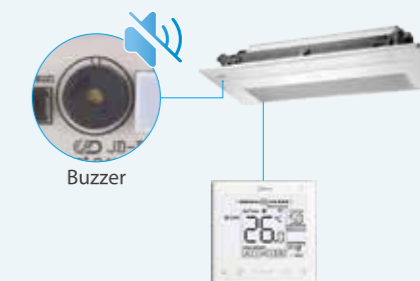

### Quiet Operation

By optimizing the design of fan motor, air duct and heat exchanger, the new duct operates with noise as low as 22dB(A), creating a quieter and more comfortable environment



## HEALTH

### Automatic anti-condensation

The One-way Cassette can automatically enter and exit the anti-condensation mode by detecting its own operation data; In the anti-condensation mode, the machine can change the outlet angle of the guide vane intermittently to prevent the local temperature difference of the guide panel from being too large and avoid the occurrence of condensation.



### 0.5°C/1°C Setting Temperature Adjustment

Set temperature can be adjusted in 0.5°C or 1°C steps, enabling precise comfort control.

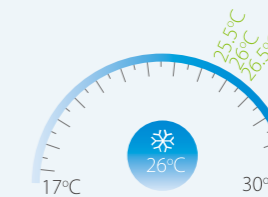
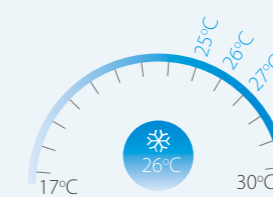

### WIDER APPLICATION

#### Auto Cooling-heating Changeover

Automatically selects cooling or heating mode to achieve the set temperature.

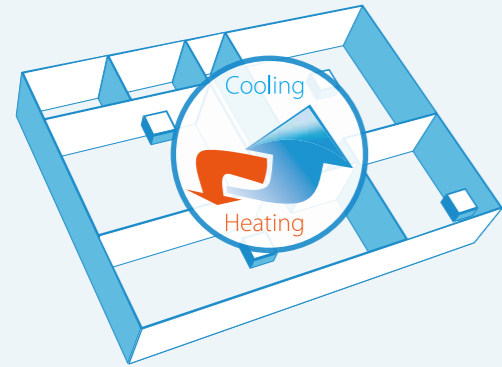

#### Multiple Steps Vertical Swing

There are 5-steps louver control makes the air flow direction more precisely. In addition, the auto swing mode can better meet different customer needs. Air supply angle 25-80°.

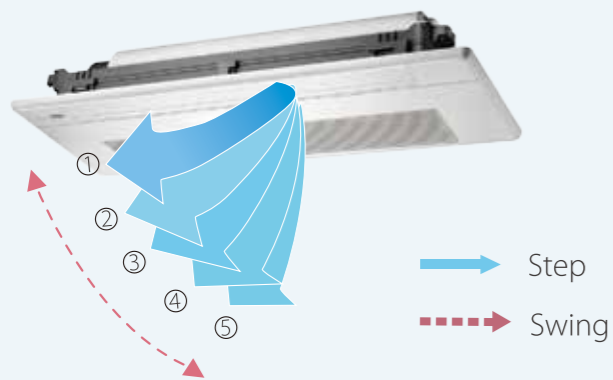

#### Digital feedback DC water pump

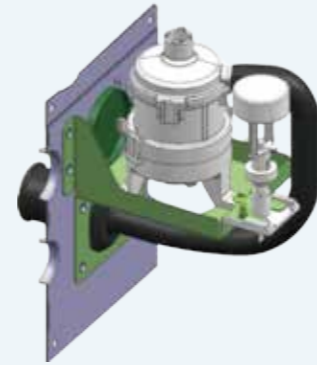

Digital feedback DC water pump: actively sense the pump speed and water flow to determine whether there is jamming attenuation or damage, and give early warning to avoid water leakage.

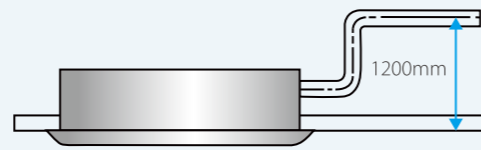

#### High-lift drain pump

A drain pump with a 1200mm raise height is fitted as standard, simplifying installation of the drain piping.



-  Free drainage
-  Quiet operation
-  High-lift drain pump



### Two-Way Cassette



# COMFORT

## Digital Display On/Off

Indoor unit displays can be shut off at night, creating a better environment for rest.



Digital display

## Buzzer Sound On/Off

Indoor unit buzzer sound can be set off to not disturb the user, creating a quieter environment.

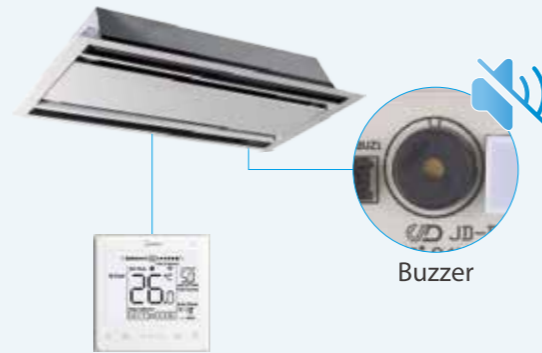

Buzzer

## Quiet Operation

The fan motor and water pump are DC power supply, which is more energy-saving and silent than AC power supply, creating a more quiet and comfortable environment

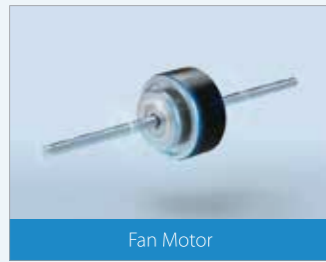

Fan Motor



Drain Pump

# HEALTH

## Automatic anti-condensation

The Two-way Cassette can automatically enter and exit the anti-condensation mode by detecting its own operation data; In the anti-condensation mode, the machine can change the outlet angle of the guide vane intermittently to prevent the local temperature difference of the guide panel from being too large and avoid the occurrence of condensation.



## 0.5° C/1° C Setting Temperature Adjustment

Set temperature can be adjusted in 0.5°C or 1°C steps, enabling precise comfort control.

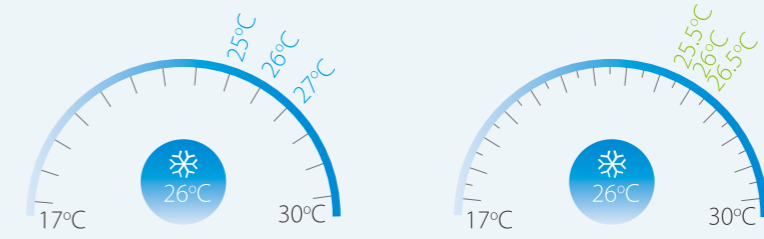

# WIDER APPLICATION

## Auto Cooling-heating Changeover

Automatically selects cooling or heating mode to achieve the set temperature.

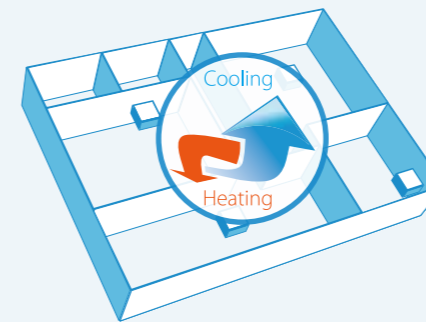

## 5-Steps Louver Control

There are 5-steps louver control makes the air flow direction more precisely. In addition, the auto swing mode can better meet different customer needs. Air supply angle 35-65°.

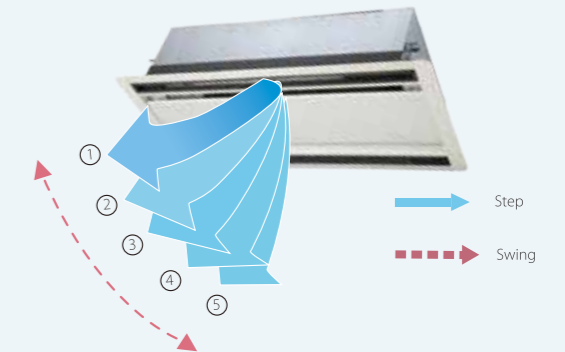

## Digital feedback DC water pump

Digital feedback DC water pump: actively sense the pump speed and water flow to determine whether there is jamming attenuation or damage, and give early warning to avoid water leakage.

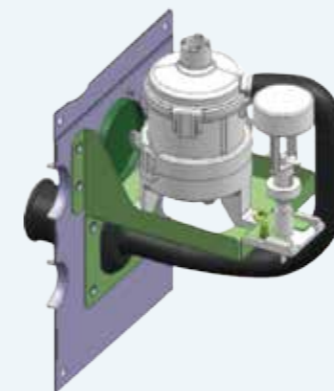

## High-lift drain pump

A drain pump with a 1200mm raise height is fitted as standard, simplifying installation of the drain piping.

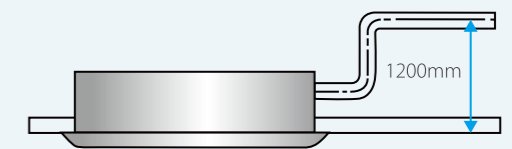

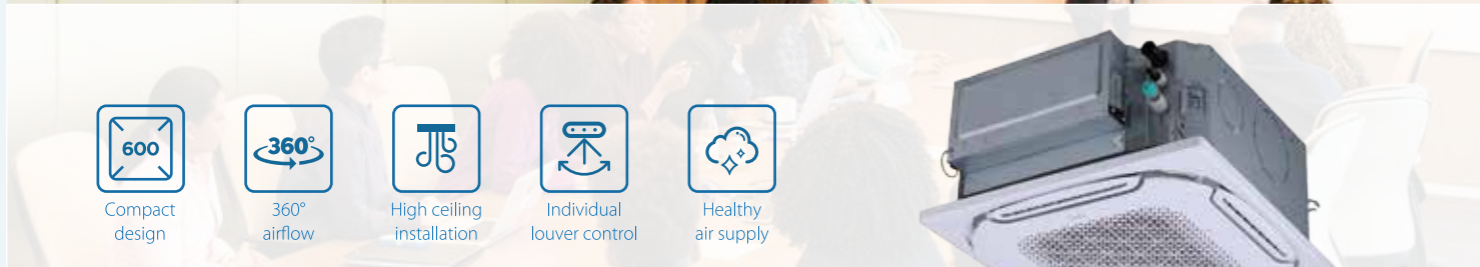

## Compact Four-Way Cassette



## COMFORT

### EEV automatic adjustment

When in heating standby mode, the indoor unit automatically adjusts the EEV opening according to the load to eliminate noise of refrigerant flowing.

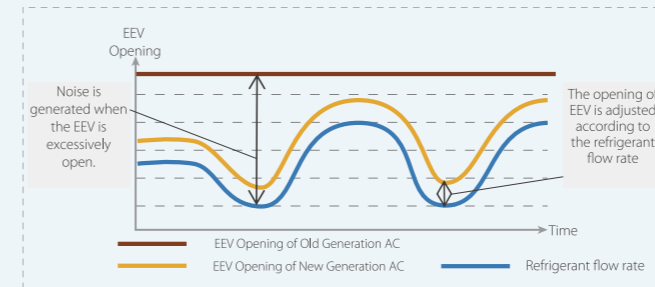

### Two thermistors control

The indoor temperature can be checked using the thermistor in the wired controller as well as from the indoor unit.

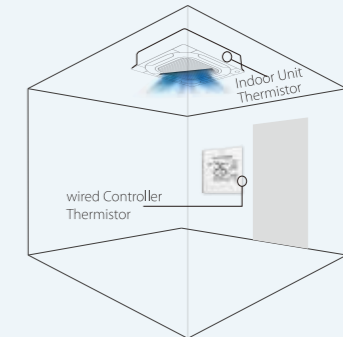

### Human Detect Sensor\*

Using millimeter-wave radar sensor controller automatically turns indoor units on or off upon detecting that the room is occupied or unoccupied, ensuring climate control whilst minimizing energy consumption.



The indoor unit automatically runs when detecting human body

The indoor unit automatically stops when detecting absence

\*This function is available as a customization option for V8 Compact Four Way Cassette.

### Auto Cooling-heating Changeover

Automatically selects cooling or heating mode to achieve the set temperature.

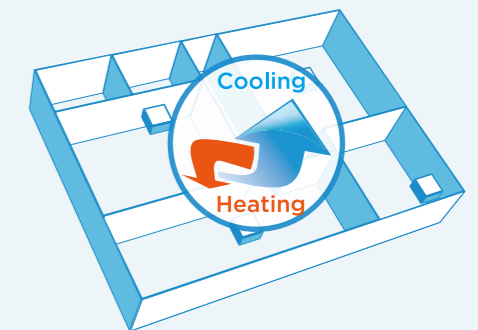

## AIR FLOW

### 360° Airflow

New design, round airflow path ensures uniform airflow and temperature distribution.

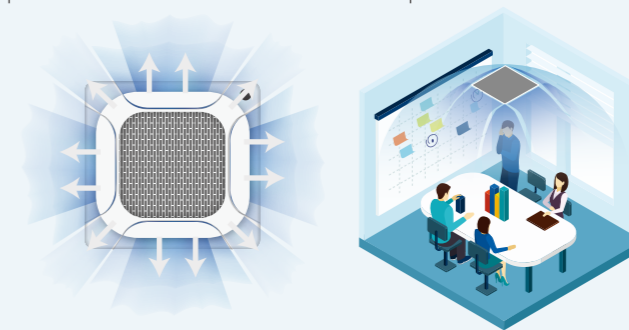

The continuous air supply port air supply area increases by 20%

### Multiple Steps Vertical Swing

The Compact Four-way Cassette unit has a wide range of airflow angles from 40° to 70° and is equipped with a 5-step louver control and auto swing mode to better meet the needs of different customers

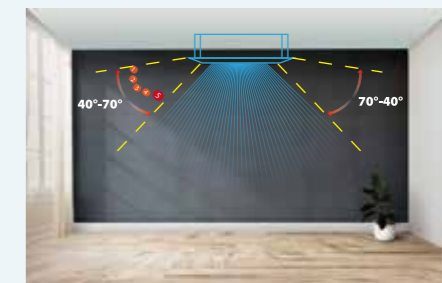

### 7 Fan Speeds

7 indoor fan speed options to meet the needs of different indoor conditions.

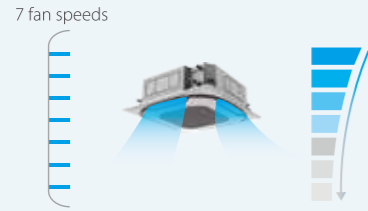

### Long Distance Air Delivery

The Compact Four-way Cassette has an additional 30Pa static pressure for long airflow delivery and is capable of being used in spaces up to 3.5m in floor height.

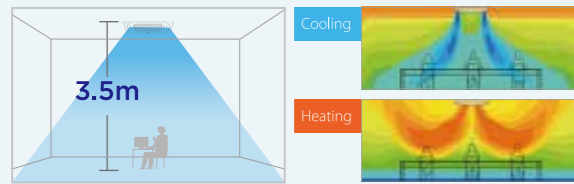

### Individual Louver Control

The Individual louver control can control the motors separately, making it possible to control all four louvers independently.

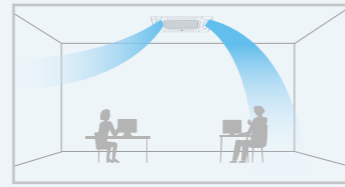

### Soft Wind Mode

Supplies air against the ceiling to create windless environment.



## HEALTH

### Optional F6-class Air Filter

The Compact Four-way Cassette supports 30Pa external static pressure for the F6-class filter installation. Filtering effect of the F6-class filter reaches up to 80% against particles (particle size > 1µm), creating a cleaner living environment.

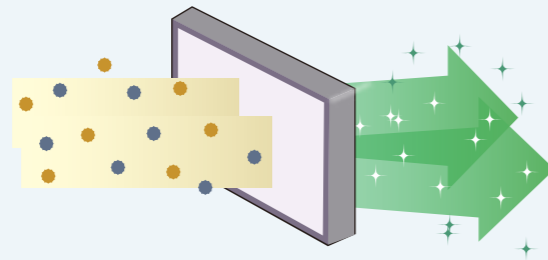

### Mildew proof of heat exchanger

When the indoor unit is turned off in cooling mode, the fan is still on, and dry the heat exchanger to avoid mold on the heat exchanger.

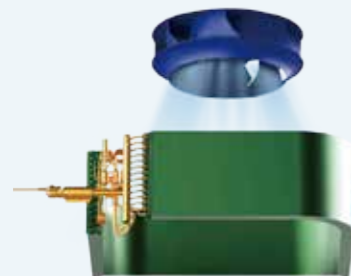

### Silver Ions drain pan (optional)

Slow-released nano-silver ions can keep the drain pan free of mold for a long time.

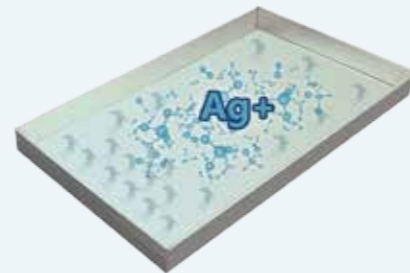

## EASY INSTALLATION

### Compact and stylish design

New Compact Four-way Cassette panel size is fit into the ceiling tile(620mm × 620mm), making installation easier.

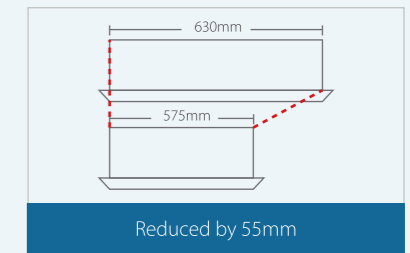
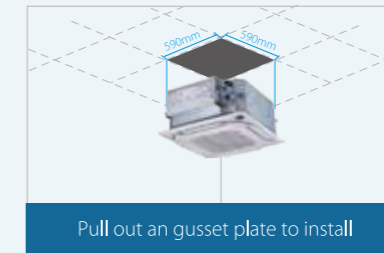
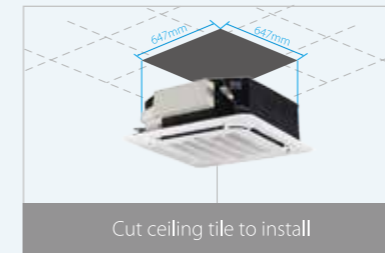

### High-lift drain pump

A drain pump with a 1200mm raise height is fitted as standard, simplifying installation of the drain piping.

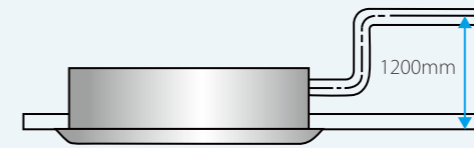

### Water level switch

When the drain pipe is blocked or the drain pipe is poor, the water level switch is turned off, and there is no need to worry about overflowing the ceiling.



### Air baffle fittings for irregular rooms

Some air discharge ports can be blocked with air baffle to optimize air distribution in irregular shaped rooms. Air outlets can be blocked with accessories, which can be found in the packing material.

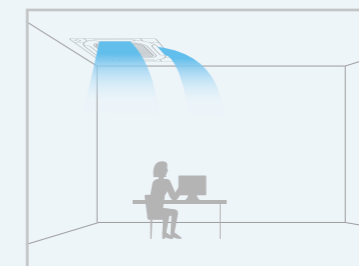

At the corner

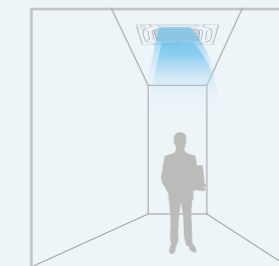

In the narrow room



360°  
airflow



Individual  
louver control



Healthy  
air supply



## Four-Way Cassette



## COMFORT

### EEV automatic adjustment

When in heating standby mode, the indoor unit automatically adjusts the EEV opening according to the load to eliminate noise of refrigerant flowing.

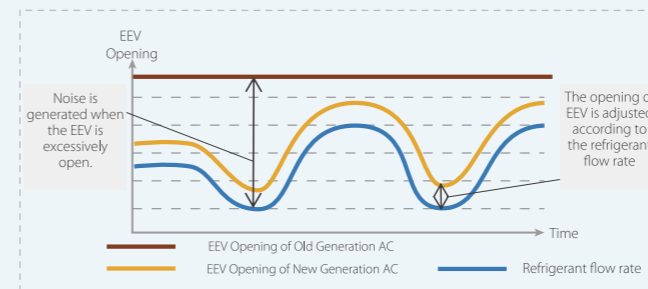

### Human Detect Sensor\*

Using millimeter-wave radar sensor controller automatically turns indoor units on or off upon detecting that the room is occupied or unoccupied, ensuring climate control whilst minimizing energy consumption.



The indoor unit automatically runs when detecting human body

The indoor unit automatically stops when detecting absence

\*This function is available as a customization option for V8 Four Way Cassette.

## AIR FLOW

### 360° Airflow

New design, round airflow path ensures uniform airflow and temperature distribution.

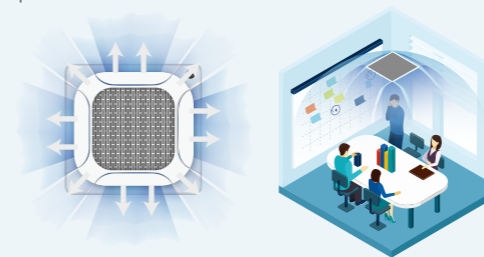

The continuous air supply port air supply area increases by 20%

### 7 Fan Speeds

7 indoor fan speed options to meet the needs of different indoor conditions.

7 fan speeds



### Two thermistors control

The indoor temperature can be checked using the thermistor in the wired controller as well as from the indoor unit

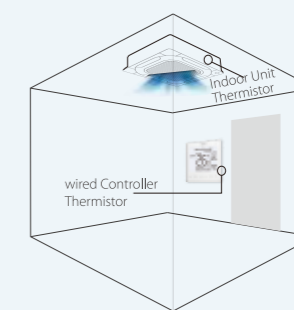

### Auto Cooling-heating Changeover

Automatically selects cooling or heating mode to achieve the set temperature.

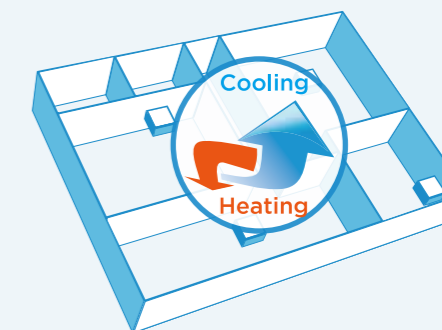

### Multiple Steps Vertical Swing

The Four-way Cassette unit has a wide range of airflow angles from 30° to 65° and is equipped with a 5-step louver control and auto swing mode to better meet the needs of different customers

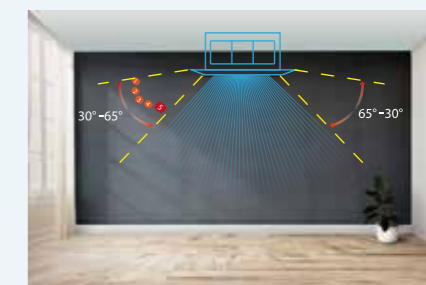

### Individual Louver Control

The Individual louver control can control the motors separately, making it possible to control all four louvers independently.

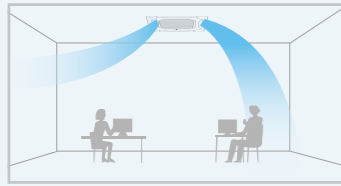

### Soft Wind Mode

Supplies air against the ceiling to create windless environment.



## HEALTH

### Mildew proof of heat exchanger

When the indoor unit is turned off in cooling mode, the fan is still on, and dry the heat exchanger to avoid mold on the heat exchanger.

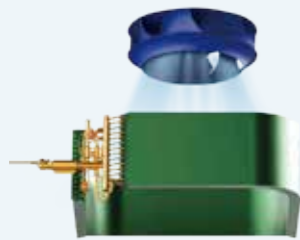

### Silver Ions drain pan (optional)

Slow-released nano-silver ions can keep the drain pan free of mold for a long time.

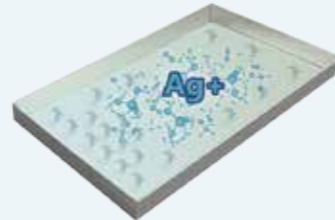

## EASY INSTALLATION

### Air baffle fittings for irregular rooms

Some air discharge ports can be blocked with air baffle to optimize air distribution in irregular shaped rooms. Air outlets can be blocked with accessories, which can be found in the packing material.

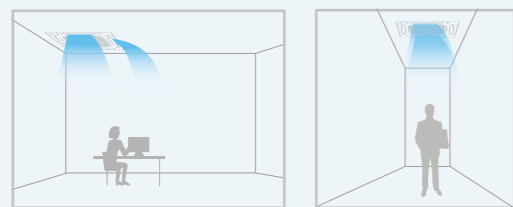

At the corner

In the narrow room

### High-lift drain pump

A drain pump with a 1200mm raise height is fitted as standard, simplifying installation of the drain piping.

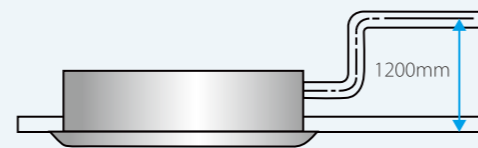

### Water level switch

When the drain pipe is blocked or the drain pipe is poor, the water level switch is turned off, and there is no need to worry about overflowing the ceiling.



Ultra-thin height



Quiet operation



Healthy air supply



Constant air volume



## Arc Duct



# COMFORT

## Quiet Operation

By optimizing the design of fan motor, air duct and heat exchanger, the new duct operates with noise as low as 22dB(A), creating a quieter and more comfortable environment.



- > Fan motor noise reduction
- > Air duct noise reduction
- > Heat exchanger noise reduction

## Two thermistors control

The indoor temperature can be checked using the thermistor in the wired controller as well as from the indoor unit

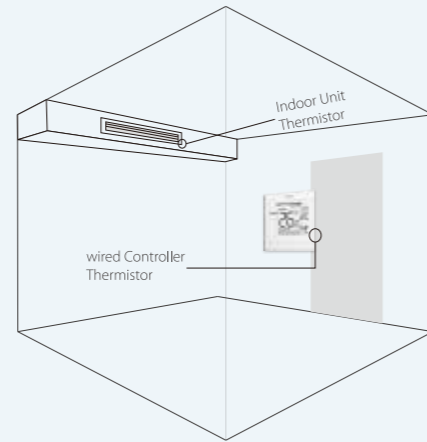

## Auto Cooling-heating Changeover

Automatically selects cooling or heating mode to achieve the set temperature.

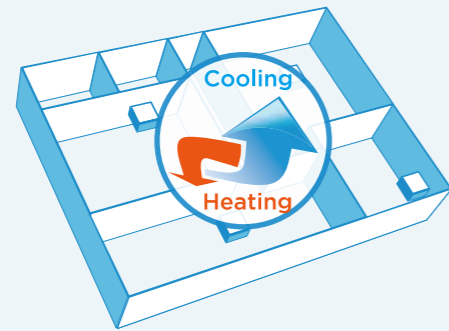

# AIR FLOW

## Constant Airflow

Constant airflow technology can realize the airflow output is not affected by installation conditions and use conditions, ensuring the constant airflow supply.

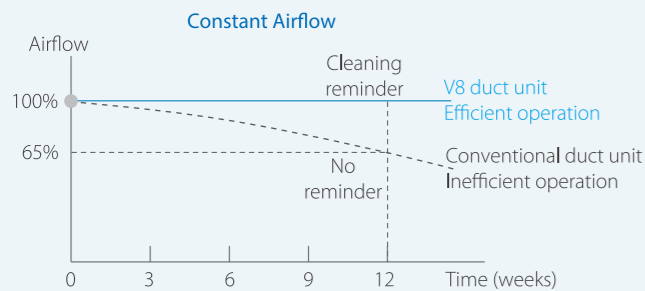

\*Data measured in the UX lab of Midea

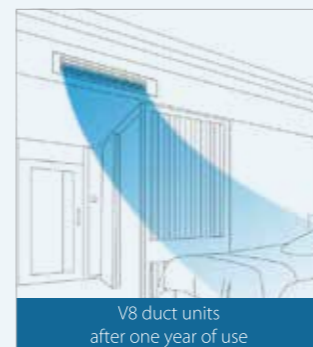
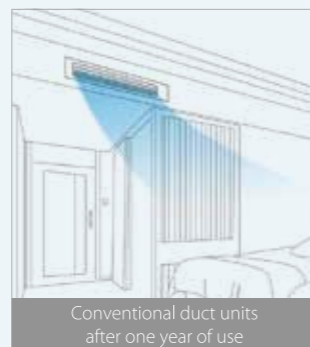

# HEALTH

## Healthy Air Supply

The Arc Duct unit adopts an integrated C-shaped heat exchanger that allows for fast drainage and no dust or ash accumulation. The optional long-life filter, medium-life filter further enhance the air quality of the air supply and create a healthy environment.

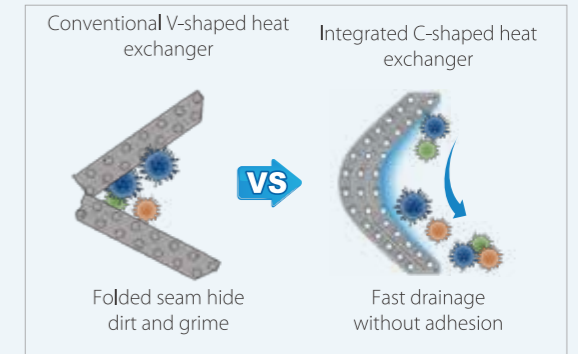
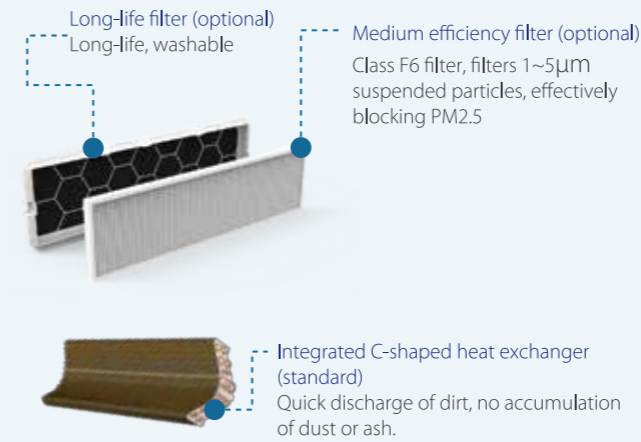

## Silver Ions drain pan (optional)

Slow-released nano-silver ions can keep the drain pan free of mold for a long time.

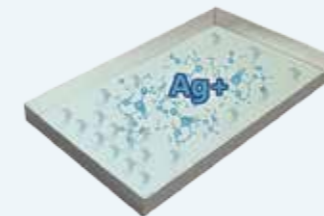

# EASY INSTALLATION

## Ultra-thin Body

Ultra-thin body design, the body height of the whole series is only 199mm, greatly saving space and more flexible installation.

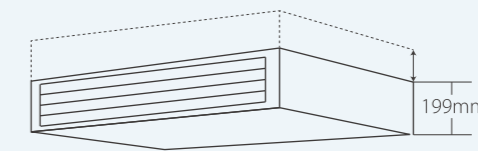

## High-lift drain pump

A drain pump with a 1200mm raise height is fitted as standard, simplifying installation of the drain piping.

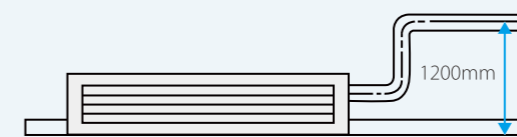

## Fault Feedback

Early warning of drain pump fault.

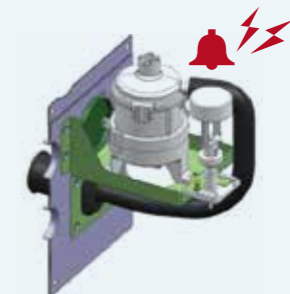



Compact design



Healthy air supply



Constant air volume



Flexible installation



## Medium Static Pressure Duct

## COMFORT

### Quiet Operation

By optimizing the design of fan motor, air duct and heat exchanger, the new duct operates with noise as low as 22dB(A), creating a quieter and more comfortable environment.



### 0.5°C/1°C Setting Temperature Adjustment

Set temperature can be adjusted in 0.5°C or 1°C steps, enabling precise comfort control.

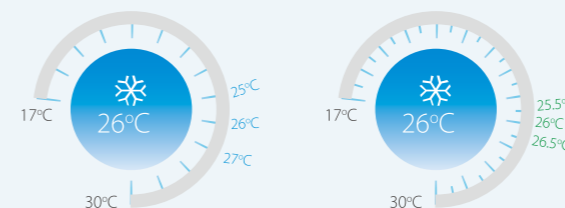

### Auto Cooling-heating Changeover

Automatically selects cooling or heating mode to achieve the set temperature.

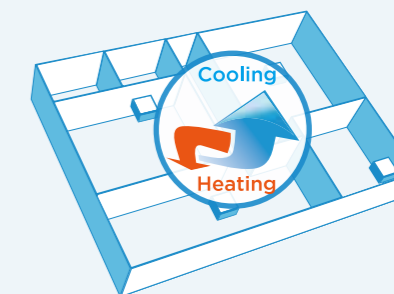

## AIR FLOW

### Adaptive Duct Length and Filter Resistance

By digital fan motor and a specially designed independent drive chip enables precise control and output on demand. It can automatically adapt to duct lengths from 10 to 160 Pa equivalent static pressure without intervention from the installer.

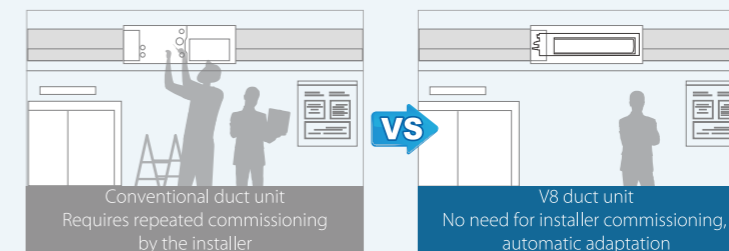

## HEALTH

### Optional High Efficiency HEPA Filter\*

A static pressure of up to 160 Pa enables the application of medical-grade HEPA filters, and even small capacity models can be equipped with high-efficiency filters, efficiently filtering fine particles of 0.5 microns with an efficiency of over 99%.

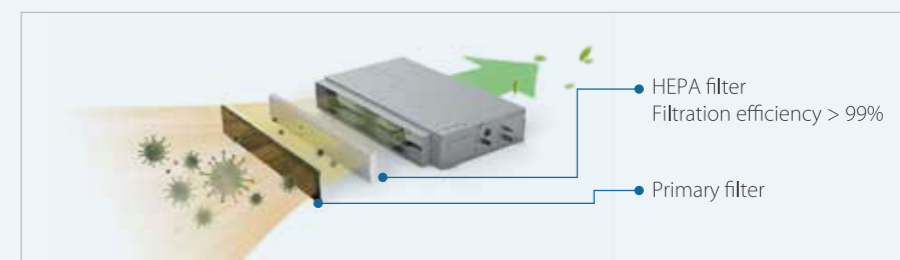

\* This function is available as a customization option.

# EASY INSTALLATION

## Thin Body with High ESP

All models have a static pressure of 160 Pa and a thickness of only 245 mm. The high static pressure allows air to be delivered over longer distances without loss of cooling and heating effect. Especially suitable for long and narrow spaces.

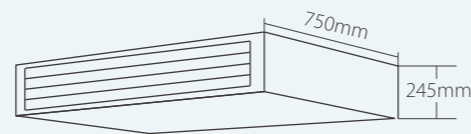
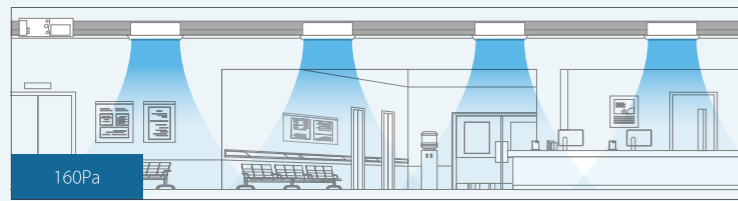

## 3 Way flexible installation\*

It is possible to install and connect the outdoor unit in 3 different ways for Duct, providing flexibility to accommodate a wide range of room designs.

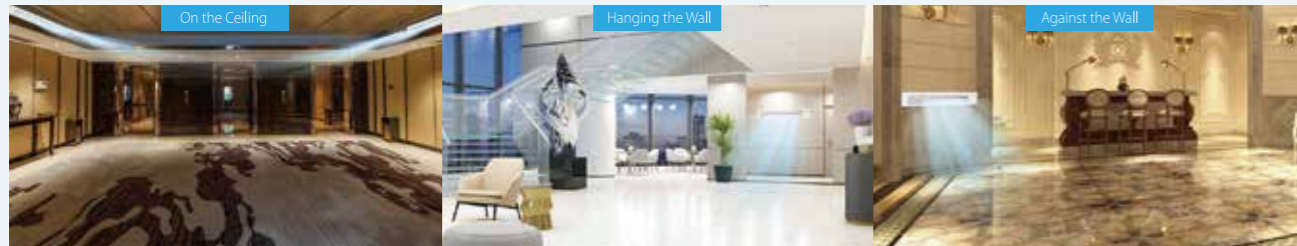

\*Hanging the Wall and Against the Wall are available as customization options.

## High-lift drain pump

A drain pump with a 1200mm raise height is fitted as standard, simplifying installation of the drain piping.

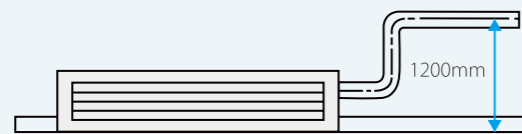

## Fault Feedback

Early warning of drain pump fault.

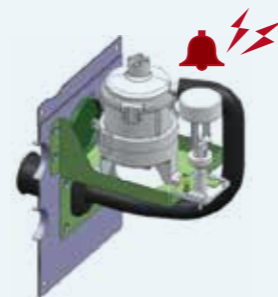

Compact design    Healthy air supply    Constant air volume    Flexible installation

# High Static Pressure Duct



## AIR FLOW

### Constant Airflow Technology

Through the independent constant air volume digital fan technology, the air volume is independently detected and adjusted to realize constant air volume and no attenuation in the whole life.

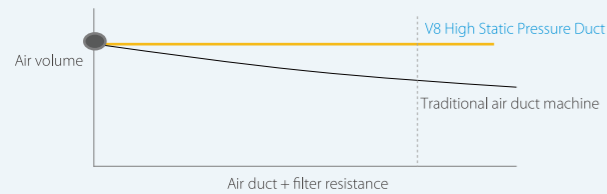

### Ultra-high static pressure

The static pressure can reach 250Pa(5.6-16kW) or 400Pa(20-56kW), so the air supply distance is longer. Especially in long and narrow spaces such as corridors, it can reduce the number of units used and save investment costs..

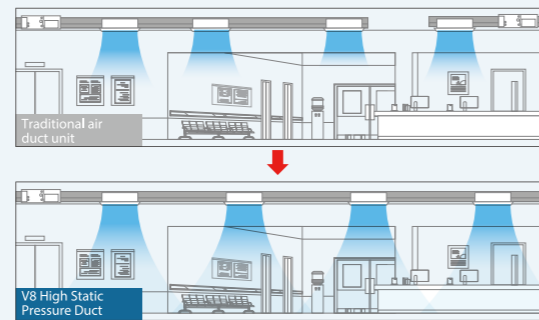

## HEALTH

### Visualization of dirty blockage rate

Built-in self-learning model can detect the real-time resistance of the filter screen and restore the true state of the filter screen. 10 levels blockage rates can be accurately identified and displayed on the controller, reminding the user to clean the filter in time.

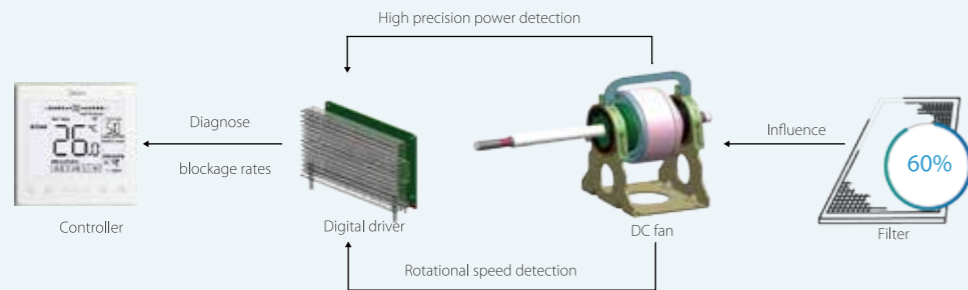

### Innovative Puro-air Kit

Protectors of health and safety

From Germany -OSRAM quality UV light source

Ozone-Free  
UV leakage-Free

\*The indoor unit needs to be customized in order to use the Puro-air Kit.



### Efficiency filter screen

Optional F7 or H13-class air filter, Equipped with H13 HEPA high-efficiency filter screen, it can filter 0.5 micron extremely fine particles, and the primary filtration efficiency is more than 99.95%.

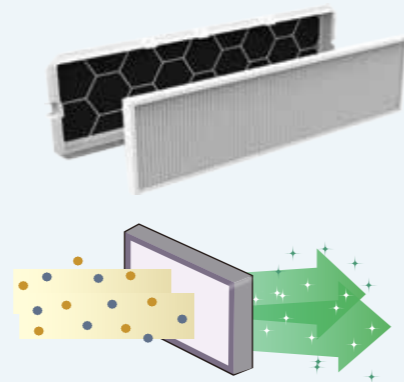

## WIDER APPLICATION

### Intelligent leak feedback

Digital feedback DC water pump, Take the initiative to sense the pump speed and water flow, judge whether there is jamming attenuation or damage, and give early warning to avoid water leakage

Integrated drainage pipe design reduces the sealing points of traditional design from 6 to 2, reduces breakpoints and reduces leakage risks

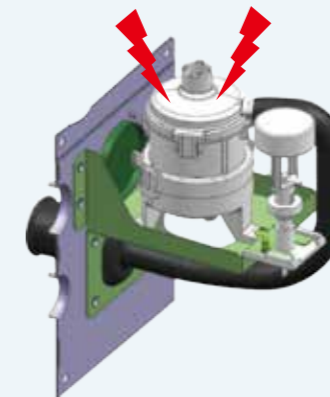

### Ultra-thin fuselage

For High static pressure duct(5.6-16kW), the fuselage thickness is only 299mm, the height required for ceiling installation is greatly reduced which leads to be able to cope with more installation situations.

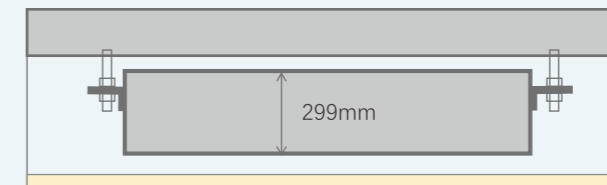

A drain pump with a 1200mm raise height is fitted as standard, simplifying installation of the drain piping.

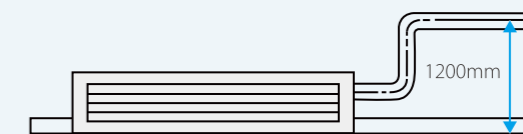

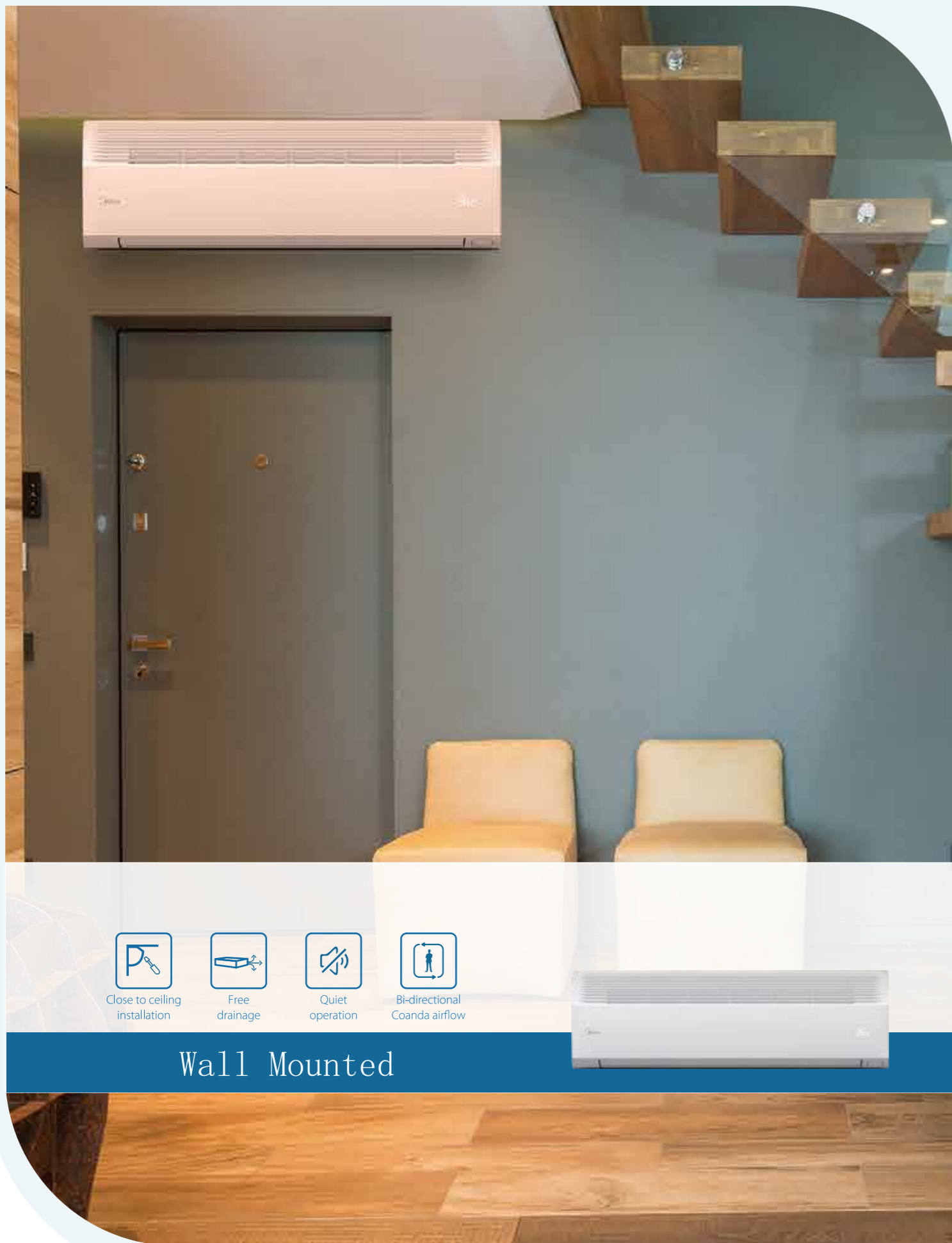

- Close to ceiling installation
- Free drainage
- Quiet operation
- Bi-directional Coanda airflow

## Wall Mounted

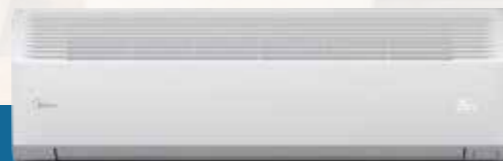

## COMFORT

### Quiet Operation

The minimum noise level of Wall Mounted is as low as 27dB(A), idea for hotels and other noise-sensitive locations.

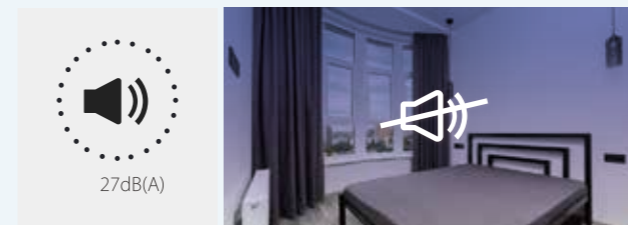

### Enclosed design

For Wall Mounted throttling parts and drain pumps adopt closed design, reducing noise.

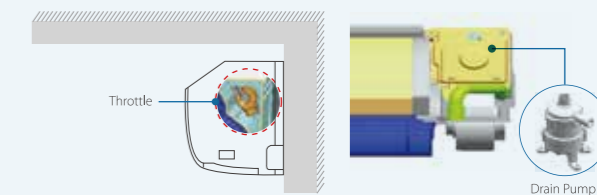

### Human Detect Sensor\*

Using millimeter-wave radar sensor controller automatically turns indoor units on or off upon detecting that the room is occupied or unoccupied, ensuring climate control whilst minimizing energy consumption.



\*This function is available as a customization option for V8 Wall Mounted.

### Auto Cooling-heating Changeover

Automatically selects cooling or heating mode to achieve the set temperature.

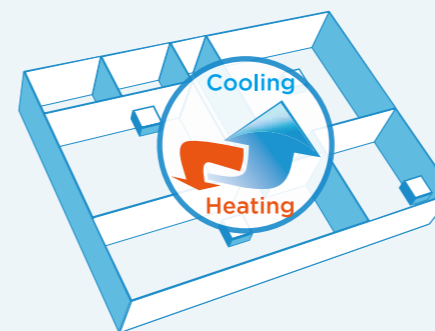

### Sleep Mode

The smart sleep mode provides a comfortable sleep period and a refreshing wake up time.



\*Temperature on left is for reference.

## AIR FLOW

### 3D Air Flow\*

Possibility to select automatic vertical and horizontal moving of the air discharge louvre, for uniform air flow and temperature distribution.



Up & Down

Right & Left

\*Horizontal Swing function is available as a customization option for Wall Mounted.

### Bi-directional Coanda Airflow

With bi-directional Coanda airflow delivery technology, the cold air does not blow directly on people and the hot air warms up evenly from the feet for better comfort.

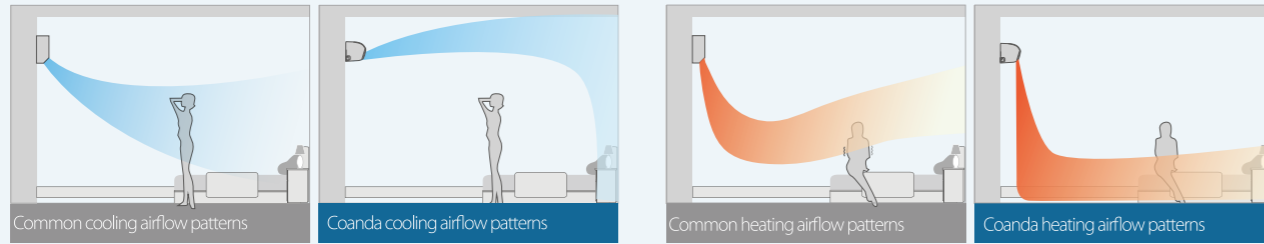

## EASY INSTALLATION

### Ceiling Mounting

The Wall Mounted new heat exchanger is designed to meet the installation requirements close to the ceiling, and the minimum distance from the ceiling is 3cm.

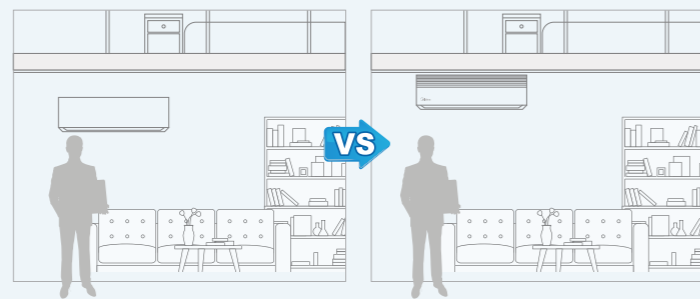

There is some distance from ceiling

The distance from the ceiling is 3cm

### Free Drainage without Space Restrictions

The Wall Mounted can realize horizontal drainage, downward drainage, upward drainage, making installation more flexible.

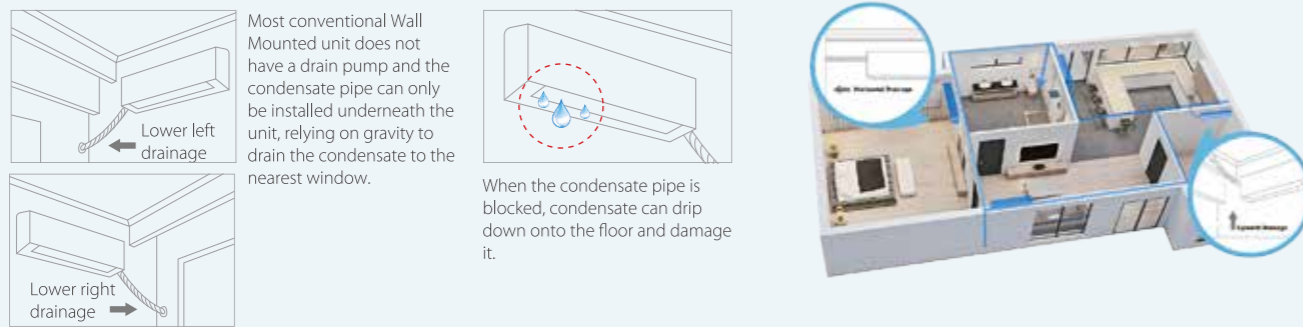

Most conventional Wall Mounted unit does not have a drain pump and the condensate pipe can only be installed underneath the unit, relying on gravity to drain the condensate to the nearest window.

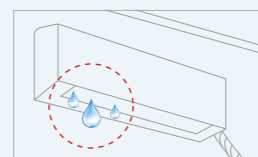

When the condensate pipe is blocked, condensate can drip down onto the floor and damage it.

### High-lift drain pump\*

A drain pump with a 1200mm raise height is fitted as a customization option, simplifying installation of the drain piping.

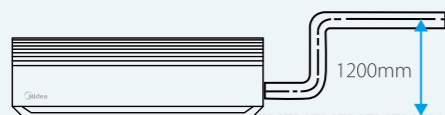

\*The drain pump is available as a customization option.

### Fault Feedback

Early warning of drain pump fault.

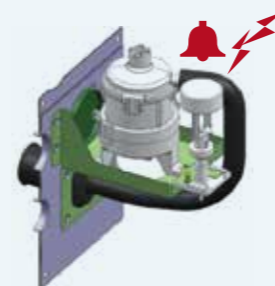

## Floor Standing F3-F4-F5



## COMFORT

### Digital Display On/Off

Indoor unit displays can be shut off at night, creating a better environment for rest.



### Quiet Operation

The fan motor is DC power supply, which is more energy-saving and silent than AC power supply, creating a more quiet and comfortable environment



### Buzzer Sound On/Off

Indoor unit buzzer sound can be set off to not disturb the user, creating a quieter environment.

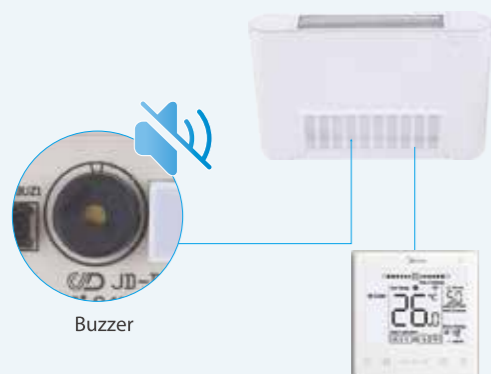

### Multiple Fan Speeds

7 indoor fan speeds provide control flexibility to meet the needs of different indoor conditions.



## HEALTH

### Dirty Filters Indicator Signal

The filter indicator will be on when the running time reaches a certain time to remind user to clean the filter.

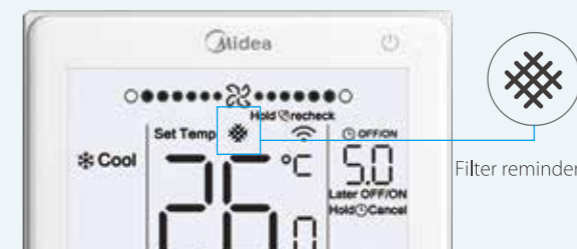

### 0.5°C/1°C Setting Temperature Adjustment

Set temperature can be adjusted in 0.5°C or 1°C steps, enabling precise comfort control.

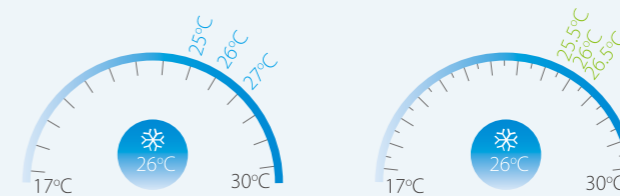

## WIDER APPLICATION

### Multiple Appearance Options

The Floor Standing Unit has three appearance options to meet different installation requirement, the F3 (concealed) unit is designed to be concealed in walls while the F4 (front air intake) and F5 (underside air intake) offer a choice of air intake options.



F3 (concealed)





F4 (front air intake)

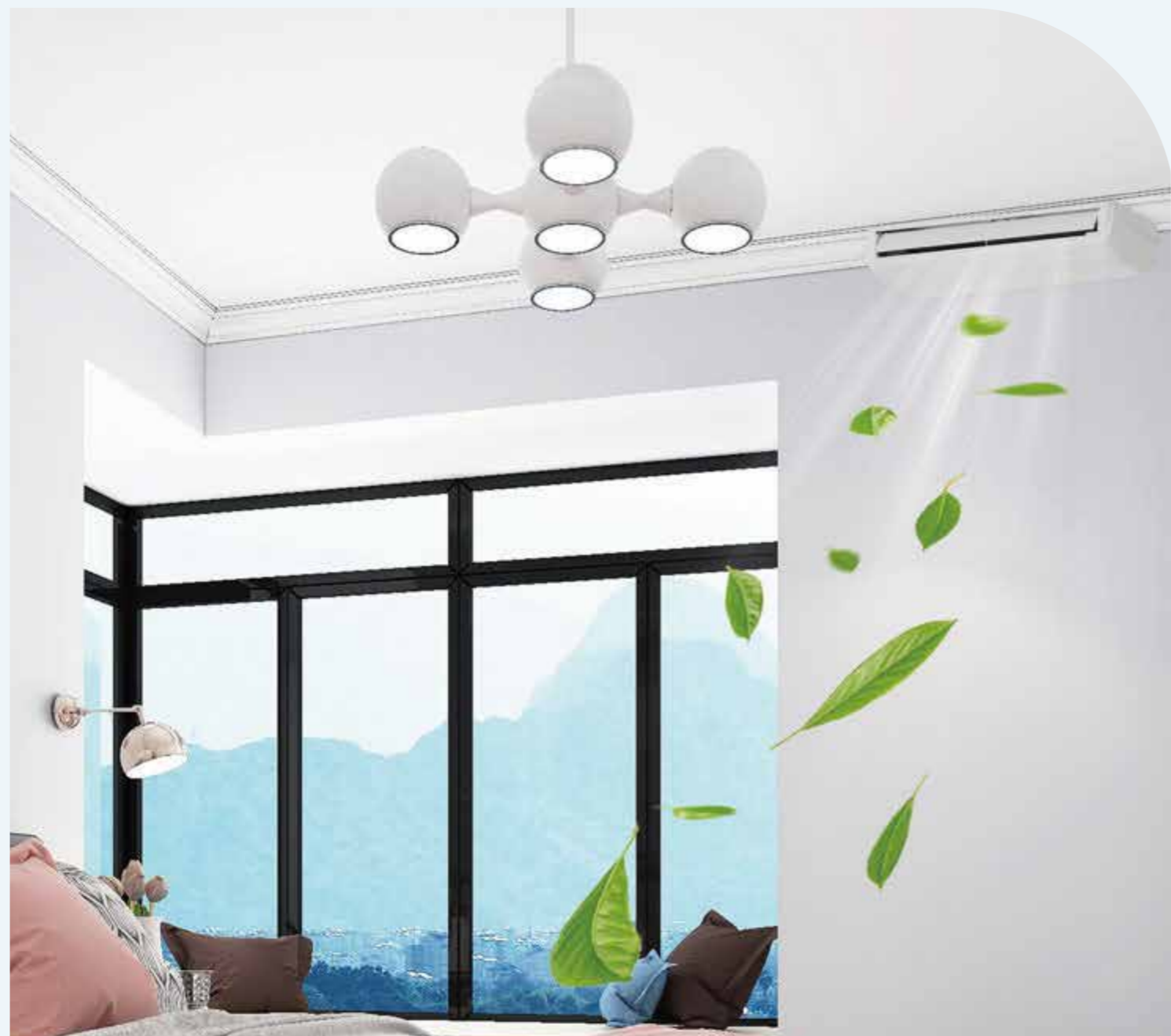

F5 (underside air intake)



-   
 Healthy  
air supply
-   
 Multi-functional  
Expansion
-   
 Flexible  
installation



## Ceiling&Floor



## Feature

### Two Installation Options

A sleek design suits installation either on the ceiling or floor, providing flexibility to accommodate a wide range of room designs.

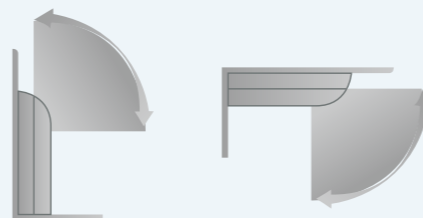

The unit can be installed either horizontally on the ceiling or vertically against the wall.

### Quiet Operation

The fan motor and water pump\* are DC power supply, which is more energy-saving and silent than AC power supply, creating a more quiet and comfortable environment



Fan Motor

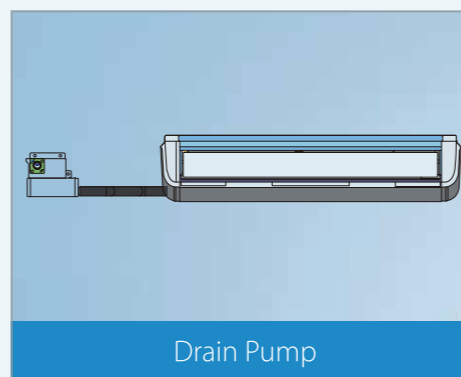

Drain Pump

\*External drain Pump is available as a customization option for unit

### Auto Cooling-heating Changeover

Automatically selects cooling or heating mode to achieve the set temperature.

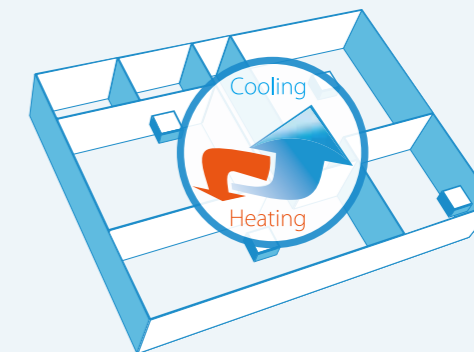

### Multiple Steps Vertical Swing

There are 5-steps louver control makes the air flow direction more precisely. In addition, the auto swing mode can better meet different customer needs. Air supply angle 35-65 °.

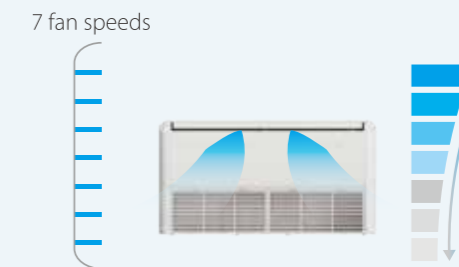

### Two thermistors control

The indoor temperature can be checked using the thermistor in the wired controller as well as from the indoor unit

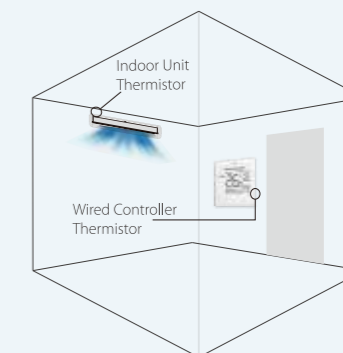



Compact design



Healthy air supply



Constant air volume



Flexible installation



## Fresh Air Processing Unit



## AIR FLOW

### Constant Airflow Technology

Through the independent constant air volume digital fan technology, the air volume is independently detected and adjusted to realize constant air volume and no attenuation in the whole life.

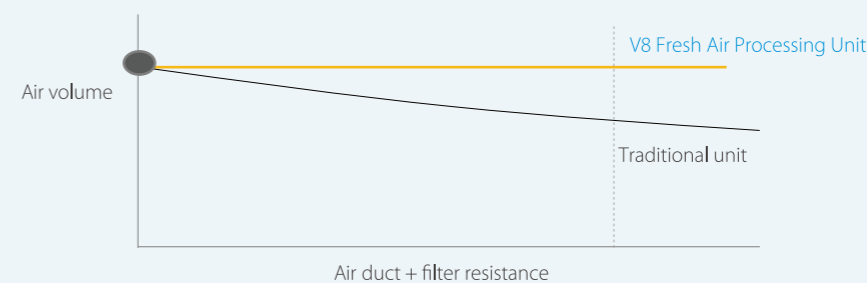

### Ultra-high static pressure

The static pressure can reach 400Pa(20-56kW), so the air supply distance is longer. Especially in long and narrow spaces such as corridors, it can reduce the number of units used and save investment costs..

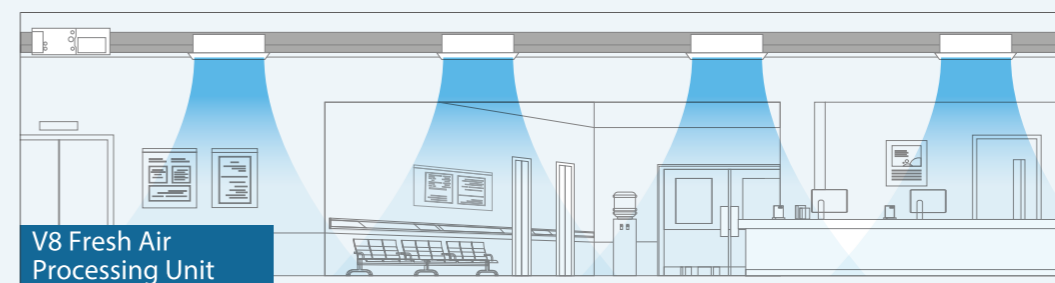
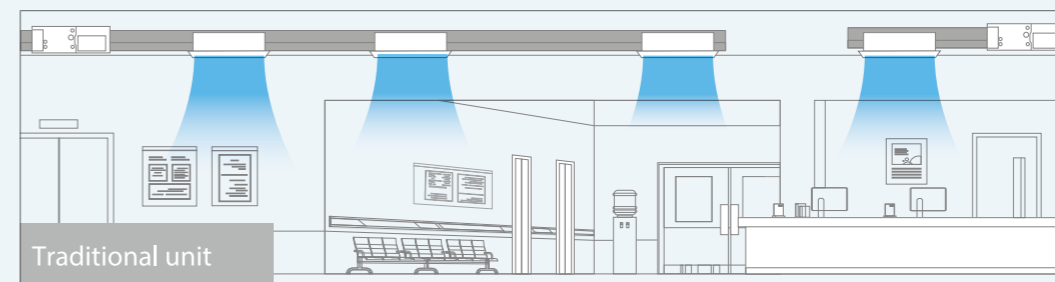

# HEALTH

## Visualization of dirty blockage rate

Built-in self-learning model can detect the real-time resistance of the filter screen and restore the true state of the filter screen. 10 levels blockage rates can be accurately identified and displayed on the controller, reminding the user to clean the filter in time.

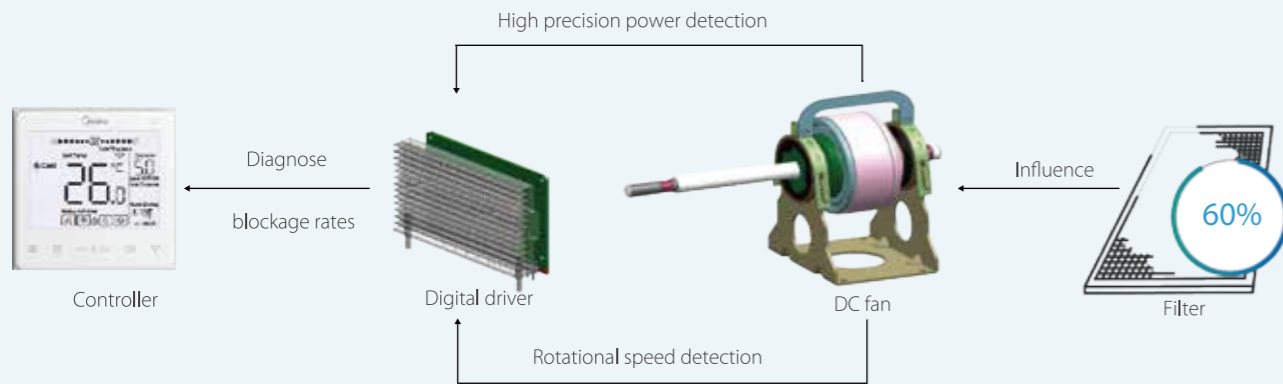

## Innovative Puro-air Kit

Protectors of health and safety

 From Germany -OSRAM quality UV light source

\*The indoor unit needs to be customized in order to use the Puro-air Kit.



# WIDER APPLICATION

## Intelligent leak feedback

Digital feedback DC water pump, Take the initiative to sense the pump speed and water flow, judge whether there is jamming attenuation or damage, and give early warning to avoid water leakage

Integrated drainage pipe design reduces the sealing points of traditional design from 6 to 2, reduces breakpoints and reduces leakage risks

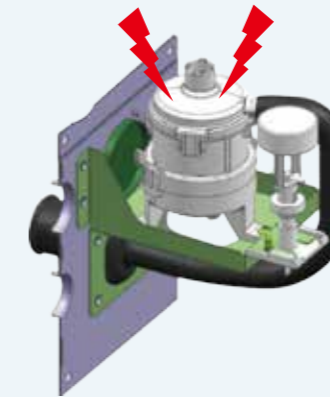

## Ultra-thin fuselage

20 -56 kW model, the fuselage thickness is only 550mm, the height required for ceiling installation is greatly reduced which leads to be able to cope with more installation situations.

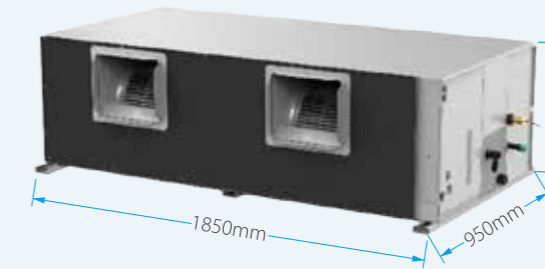

A drain pump with a 1200mm raise height is fitted as standard, simplifying installation of the drain piping.

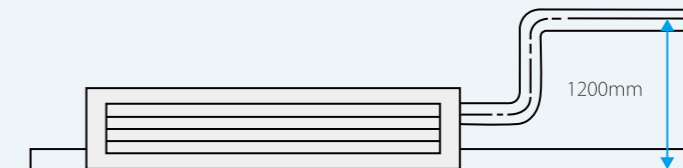



Compact design



Healthy air supply



Constant air volume



Flexible installation



## Small Airflow Rate Fresh Air Processing



## AIR FLOW

### Constant Airflow Technology

Through the independent constant air volume digital fan technology, the air volume is independently detected and adjusted to realize constant air volume and no attenuation in the whole life.

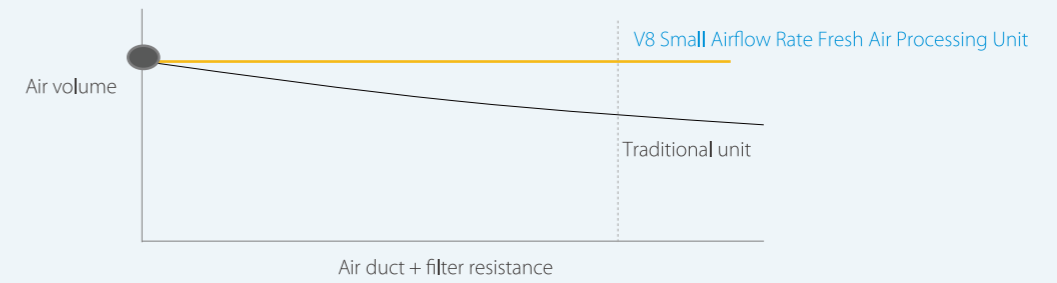

### Ultra-high static pressure

The static pressure can reach 300Pa(9-28kW), so the air supply distance is longer. Especially in long and narrow spaces such as corridors, it can reduce the number of units used and save investment costs..

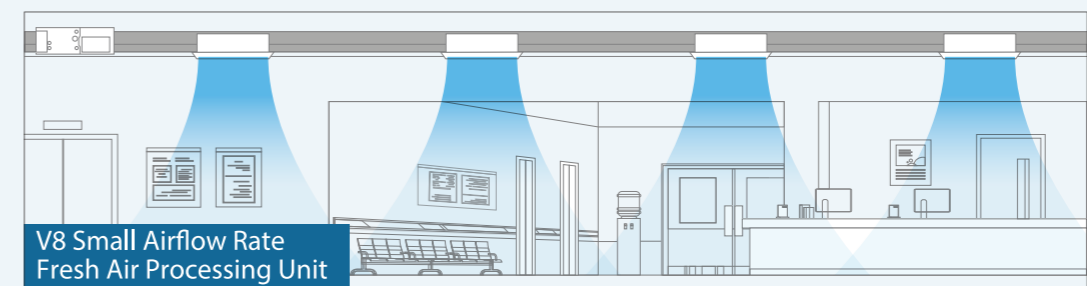

V8 Small Airflow Rate Fresh Air Processing Unit

# HEALTH

## Visualization of dirty blockage rate

Built-in self-learning model can detect the real-time resistance of the filter screen and restore the true state of the filter screen. 10 levels blockage rates can be accurately identified and displayed on the controller, reminding the user to clean the filter in time.

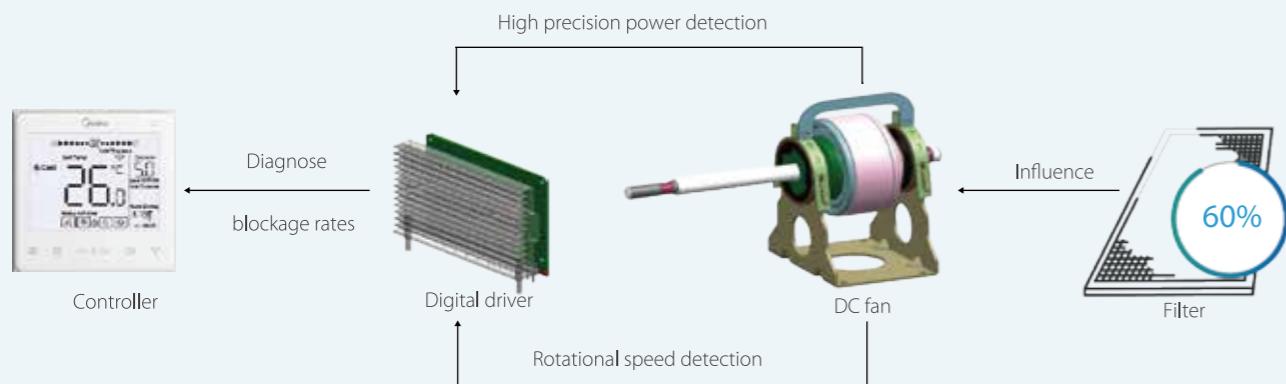

## Innovative Puro-air Kit

Protectors of health and safety

 From Germany -OSRAM quality UV light source

\*The indoor unit needs to be customized in order to use the Puro-air Kit.



# WIDER APPLICATION

## Intelligent leak feedback

Digital feedback DC water pump, Take the initiative to sense the pump speed and water flow, judge whether there is jamming attenuation or damage, and give early warning to avoid water leakage

Integrated drainage pipe design reduces the sealing points of traditional design from 6 to 2, reduces breakpoints and reduces leakage risks

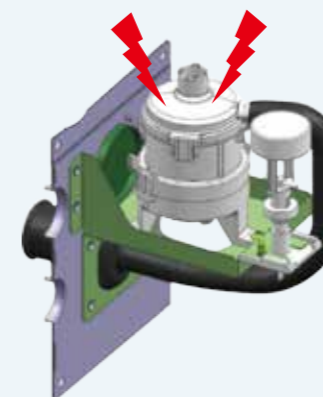

## Ultra-thin fuselage

9-28 kW model, the fuselage thickness is only 310mm, the height required for ceiling installation is greatly reduced which leads to be able to cope with more installation situations.

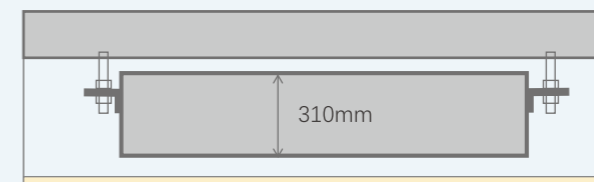

A drain pump with a 1200mm raise height is fitted as standard, simplifying installation of the drain piping.



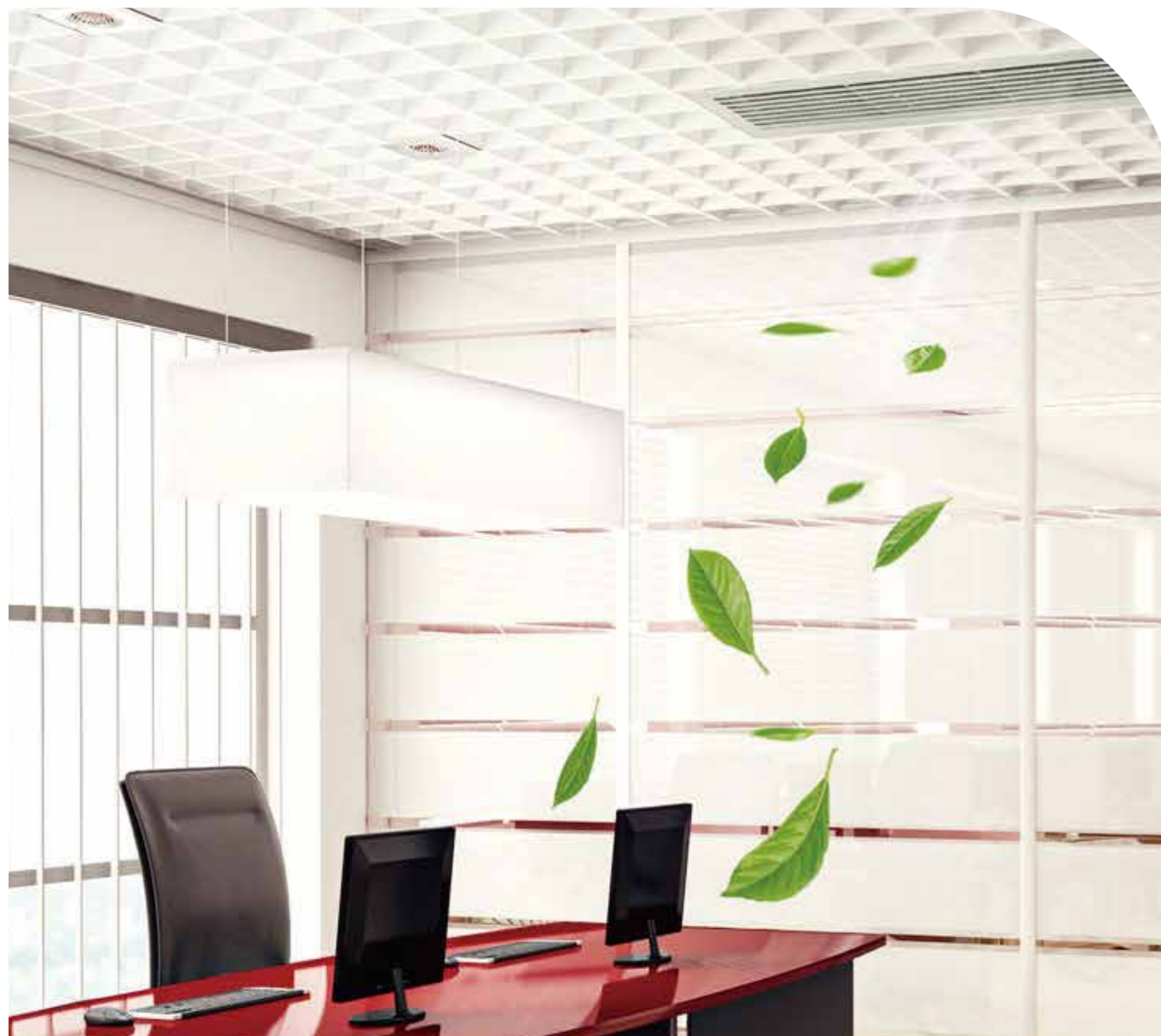

Compact design



Healthy air supply



Energy Saving



### V8 HRV



## Features

### Wide Capacity Range

The airflow is from 200m<sup>3</sup>/h to 2000m<sup>3</sup>/h which can meet the requirements of most scenarios.



200-400m<sup>3</sup>/h



500-1000m<sup>3</sup>/h



1500-2000m<sup>3</sup>/h

### Energy Saving, Heat Recovery for Both Heat and Humidity

The heat recovery ventilator (HRV) can greatly reduce energy loss and room temperature fluctuations caused by the ventilation process. The Midea HRV's strong performance is a result of the advanced technology incorporated into its design. The heat exchanger core is made of specially filter material which gives enhanced temperature and humidity control. It prevents energy being wasted by recovering waste heat from the outgoing air, thus offering much greater levels of efficiency, while improving comfort levels too.

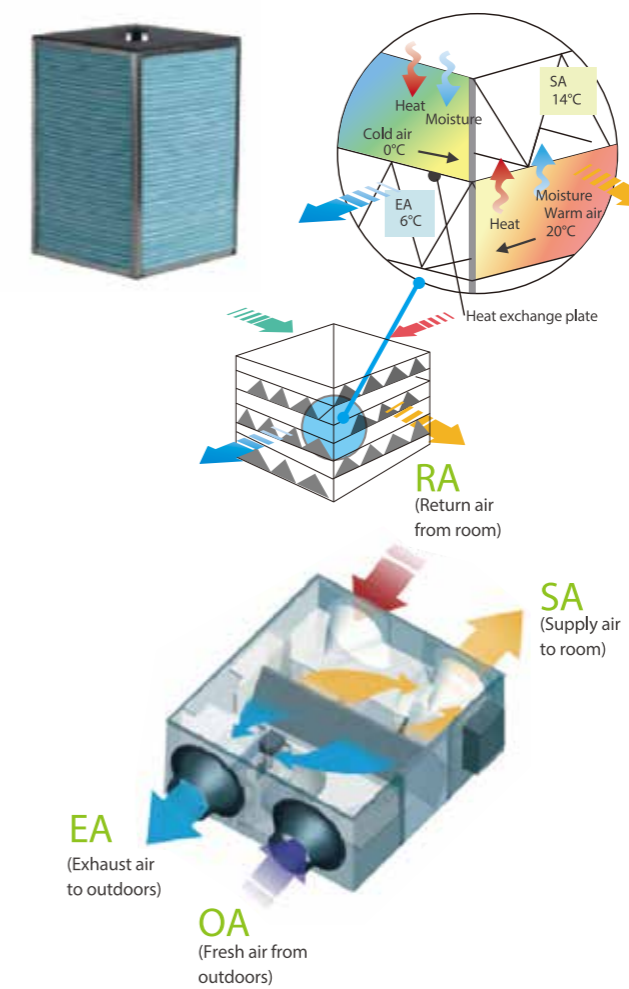

### Multiple Operation Modes

Multiple operation modes: Auto, Bypass, Heat recovery, Free cooling mode.

#### Heat exchange mode

The flows of incoming and outgoing air pass close to each other, allowing heat transfer between the two channels. During summer, incoming air is cooled by the indoor air being exhausted and in winter, incoming air is warmed.

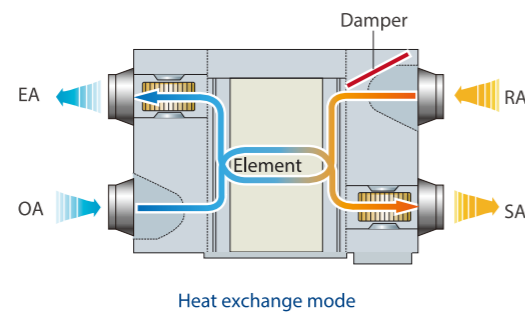

#### Bypass mode

In mild climates or seasons, where temperature and humidity differences between indoors and outdoors are small, the HRV can work as a conventional ventilation fan. In standard bypass mode the supply and exhaust fans run at the same speed.

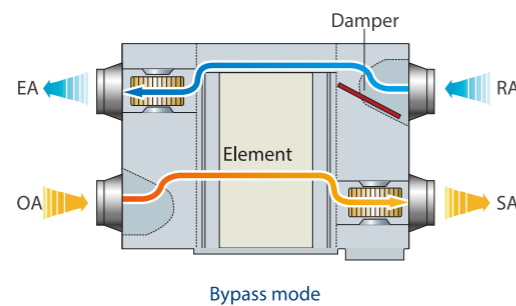

#### Auto mode

The controller chooses heat exchange mode or bypass mode according to the temperature difference between outdoors and indoors. Both fans are set to run at low speed.

#### Free Cooling Mode\*

Free cooling mode is only available for DC Series HRV. Free cooling operation is an energy saving function operating when outdoor ambient temperature is below indoor ambient temperature, it uses low temperature fresh air to cool down indoor temperature, reducing the running costs.

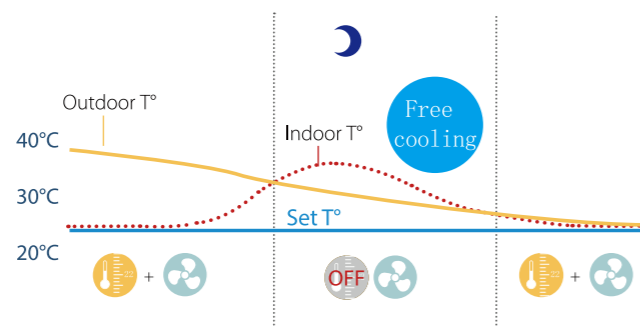

\*The function is only enabled when connected to the centralized control

### High Efficiency Filter

Standard Built-in G4-class dust filter, optional F7-class filter for air supply side and M5-class filter for exhaust air side in line with EU legislations can be customized.



Slim and compact design of units, making the installation more convenient.

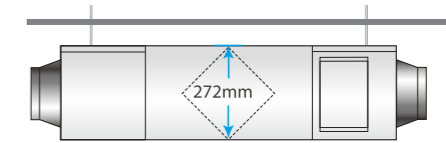

### Wide Range of Controllers.

The HRV has its special wired controller WDC3-86S2. It also can be centralized control with VRF system through centralized controller and network control with VRF system through Midea gateways.



\*The centralized control will be available in December 2023. The gateway will be available in March 2024.

### CO<sub>2</sub> Sensor Option

Enough fresh air is needed to create an enjoyable environment, but ventilating constantly is leading to energy waste. Therefore, an optional CO<sub>2</sub> sensor can be installed which switches off the ventilation system when there is enough fresh air in the room, thus saving energy.

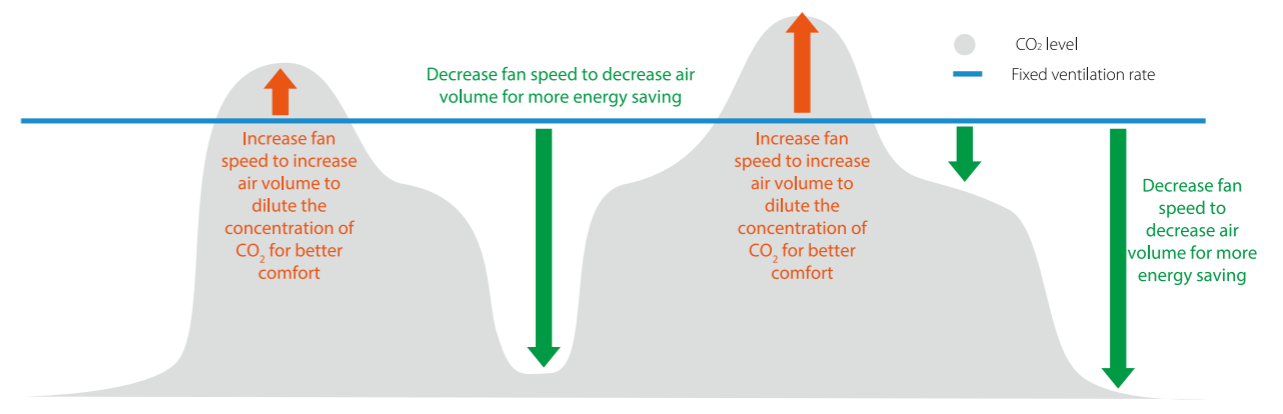



# Specifications

**One-Way Cassette**

**Two-Way Cassette**

**Compact Four-Way Cassette**

**Four-Way Cassette**

**Arc Duct**

**Medium Static Pressure Duct**

**High Static Pressure Duct**

**Wall Mounted**

**Floor Standing**

**Ceiling&Floor**

**Fresh Air Processing**

**Small Airflow Rate Fresh Air Processing**

**HRV**

# Specifications

## One-Way Cassette

Model name		MIH18Q1HN18	MIH22Q1HN18	MIH28Q1HN18	MIH36Q1HN18	MIH45Q1HN18	MIH56Q1HN18	MIH71Q1HN18	
Power supply		1-phase, 220-240V, 50/60Hz							
Cooling <sup>1</sup>	Capacity	kW	1.8	2.2	2.8	3.6	4.5	5.6	7.1
		kBut/h	6.1	7.5	9.6	12.3	15.4	19.1	24.2
Heating <sup>2</sup>	Capacity	kW	2.2	2.6	3.2	4.0	5.0	6.3	8.0
		kBut/h	7.5	8.9	10.9	13.6	17.1	21.5	27.3
Airflow rate <sup>3</sup>		m <sup>3</sup> /h	380/355/330/300/286/263/240		460/440/410/380/355/330/300		693/662/638/600/556/510/476	792/763/728/688/643/589/549	933/873/815/749/689/637/592
Sound pressure level <sup>4</sup>		dB(A)	30/28/27/26/25/24/22		37/36/35/34/32/31/30	38/37/35/34/32/31/30	39/37/36/35/34/32/31	41/39/38/37/36/35/33	43/41/40/39/37/36/35
Sound power level		dB(A)	44/42/41/40/39/38/36		51/50/49/48/46/45/44	52/51/49/48/46/45/44	53/51/50/49/48/46/45	55/53/52/51/50/49/47	57/55/54/53/51/50/49
indoor unit	Net dimensions <sup>5</sup> (W×H×D)	mm	1054×153×428			1275×189×452			
	Net dimensions (no water tray) (W×H×D)	mm	1054×141×428			1275×176×452			
	Packed dimensions (W×H×D)	mm	1155×245×490			1370×295×505			
	Net/Gross weight	kg	11.5/14.5		11.8/14.8		15.8/20.2		16.9/21.4
Panel	Net dimensions (W×H×D)	mm	1180×25×465			1350×25×505			
	Packed dimensions (W×H×D)	mm	1232×107×517			1410×95×560			
	Net/Gross weight	kg	3.5/4.7			4/5.6			
Refrigerant type			R410A/R32	R410A/R32	R410A/R32	R410A/R32	R410A/R32	R410A/R32	
Pipe connections	Liquid/Gas pipe	mm	Ø6.35/Ø12.7						
	Drain pipe	mm	OD Ø25						

Notes:

- Indoor temperature 27°C DB, 19°C WB; outdoor temperature 35°C DB; equivalent refrigerant piping length 7.5m with zero level difference.
- Indoor temperature 20°C DB; outdoor temperature 7°C DB, 6°C WB; equivalent refrigerant piping length 7.5m with zero level difference.
- Each model's 7 airflow rate options are listed in order, from highest to lowest.
- Each model's 7 sound pressure levels are listed in order from highest to lowest and correspond to the model's 7 airflow rate options (see Note 3). Sound pressure level is measured 1.4m below the unit in an anechoic chamber.
- Unit body dimensions given are the largest external dimensions of the unit, including hanger attachments.
- These products are under development and the specifications are always subject to change.

## Two-Way Cassette

Model name		MIH22Q2HN18	MIH28Q2HN18	MIH36Q2HN18	MIH45Q2HN18	MIH56Q2HN18	MIH71Q2HN18	
Power supply		1-phase, 220-240V, 50/60Hz						
Cooling <sup>1</sup>	Capacity	kW	2.2	2.8	3.6	4.5	5.6	7.1
		kBut/h	7.5	9.6	12.3	15.4	19.1	24.2
Heating <sup>2</sup>	Capacity	kW	2.6	3.2	4	5	6.3	8
		kBut/h	8.9	10.9	13.6	17.1	21.5	27.3
Airflow rate <sup>3</sup>		m <sup>3</sup> /h	654/612/571/530/488/449/410	654/612/571/530/488/449/410	725/679/641/591/554/509/458	850/792/731/670/631/592/550	980/925/855/800/755/702/670	1200/1115/1068/1000/921/808/770
Sound pressure level <sup>4</sup>		dB(A)	33/31/30/29/27/25/24	33/31/30/29/27/25/24	35/33/32/30/29/27/25	37/36/35/34/32/31/30	39/37/36/35/33/31/30	44/42/41/40/38/36/34
Sound power level		dB(A)	49/47/46/45/43/41/40	49/47/46/45/43/41/40	51/49/48/46/45/43/41	53/52/51/50/48/47/4	55/53/52/51/49/47/46	60/58/57/56/54/52/50
indoor unit	Net dimensions <sup>5</sup> (W×H×D)	mm	1172×299×591					
	Packed dimensions (W×H×D)	mm	1355×400×675					
	Net/Gross weight	kg	29.7/36.3			31.6/38.2		
Panel	Net dimensions (W×H×D)	mm	1430×53×680					
	Packed dimensions (W×H×D)	mm	1525×130×765					
	Net/Gross weight	kg	11/15			11/15		
Refrigerant type			R410A/R32	R410A/R32	R410A/R32	R410A/R32	R410A/R32	
Pipe connections	Liquid/Gas pipe	mm	Ø6.35/Ø12.7					
	Drain pipe	mm	OD Ø32					

Notes:

- Indoor temperature 27°C DB, 19°C WB; outdoor temperature 35°C DB; equivalent refrigerant piping length 7.5m with zero level difference.
- Indoor temperature 20°C DB; outdoor temperature 7°C DB, 6°C WB; equivalent refrigerant piping length 7.5m with zero level difference.
- Air flow rate are from the highest speed to the lowest speed, total 7 rates for each model.
- Sound pressure level is from highest level to lowest level, total 7 levels for each model. Sound pressure level is measured 1.4m below the unit in an anechoic chamber.
- The dimension is only the body size, excluding the size of the installation lug, connecting copper pipe, etc. For detailed dimensions, please refer to the installation manual.

# Specifications

## Compact Four-Way Cassette

Model		MIH15Q4CHN18	MIH22Q4CHN18	MIH28Q4CHN18	MIH36Q4CHN18	
Power supply		1-phase, 220-240V, 50/60Hz				
Cooling <sup>1</sup>	Capacity	kW	1.5	2.2	2.8	3.6
		kBut/h	5.1	7.5	9.6	12.3
Heating <sup>2</sup>	Capacity	kW	1.8	2.4	3.2	4.0
		kBut/h	6.1	8.2	10.9	13.7
Air flow rate <sup>3</sup>		m <sup>3</sup> /h	450/425/400/370/345/320/295		510/480/455/425/395/370/340	530/500/470/440/405/375/345
Sound pressure level <sup>4</sup>		dB(A)	29/28/27/26/26/25		30/29/28/27/26/26/25	31/30/29/28/27/26/25.5
Sound power level		dB(A)	40/39/39/38/38/38		42/41/40/39/38/38	42/40/39/38/38/38
Main body	Net dimensions <sup>5</sup> (W×H×D)	mm	575 × 235 × 638			
	Packed dimensions (W×H×D)	mm	690 × 285 × 690			
	Net/Gross weight	kg	13.0/15.5		14.0/16.5	
Panel	Net dimensions <sup>6</sup> (W×H×D)	mm	620 × 65 × 620			
	Packed dimensions (W×H×D)	mm	680 × 80 × 665			
	Net/Gross weight	kg	2.3/3.0			
Refrigerant type			R410A/R32			
Pipe connections	Liquid/Gas pipe	mm	Ø6.35/Ø12.7			
	Drain pipe	mm	OD Ø25			

Model		MIH45Q4CHN18	MIH56Q4CHN18	MIH63Q4CHN18	
Power supply		1-phase, 220-240V, 50/60Hz			
Cooling <sup>1</sup>	Capacity	kW	4.5	5.6	6.3
		kBut/h	15.4	19.1	21.5
Heating <sup>2</sup>	Capacity	kW	5.0	6.3	7.1
		kBut/h	17.1	21.5	24.2
Air flow rate <sup>3</sup>		m <sup>3</sup> /h	640/605/570/530/495/460/425	810/765/720/670/625/580/535	905/855/805/755/705/655/605
Sound pressure level <sup>4</sup>		dB(A)	36.5/35/33/31/29/28/26.5	39/38/37/36/35/34/32	43/42/40/38/36/35/33.5
Sound power level		dB(A)	44/44/43/42/41/41/41	48/46/45/43/42/42/41	51/50/48/46/45/44/42
Main body	Net dimensions <sup>5</sup> (W×H×D)	mm	575 × 235 × 638		
	Packed dimensions (W×H×D)	mm	690 × 285 × 690		
	Net/Gross weight	kg	14.0/16.5	15.0/17.5	
Panel	Net dimensions <sup>6</sup> (W×H×D)	mm	620 × 65 × 620		
	Packed dimensions (W×H×D)	mm	680 × 80 × 665		
	Net/Gross weight	kg	2.3/3.0		
Refrigerant type			R410A/R32		
Pipe connections	Liquid/Gas pipe	mm	Ø6.35/Ø12.7		
	Drain pipe	mm	OD Ø25		

Notes:

- Indoor temperature 27°C DB, 19°C WB; outdoor temperature 35°C DB; equivalent refrigerant piping length 7.5m with zero level difference.
- Indoor temperature 20°C DB; outdoor temperature 7°C DB, 6°C WB; equivalent refrigerant piping length 7.5m with zero level difference.
- Air flow rate are from the highest speed to the lowest speed, total 7 rates for each model.
- Sound pressure level is from highest level to lowest level, total 7 levels for each model. Sound pressure level is measured 1.5m below the unit in an anechoic chamber.
- The dimension is only the body size, excluding the size of the installation lug, connecting copper pipe, etc. For detailed dimensions, please refer to the installation manual.
- Exposed height of the panel after being installed on the ceiling.

# Specifications

## Four-Way Cassette

Model			MIH28Q4HN18	MIH36Q4HN18
Power supply			1-phase, 220-240V, 50/60Hz	
Cooling <sup>1</sup>	Capacity	kW	2.8	3.6
		kBtu/h	9.6	12.3
	Power input	W	17.0	17.0
Heating <sup>2</sup>	Capacity	kW	3.2	4.0
		kBtu/h	10.9	13.7
	Power input	W	17.0	17.0
Air flow rate <sup>3</sup>	m <sup>3</sup> /h		790/740/691/641/591/542/492	790/740/691/641/591/542/492
Sound pressure level <sup>4</sup>	dB(A)		30/29/28/27.5/27/26/25	30/29/28/27.5/27/26/25
Sound power level	dB(A)		44/43/42/42/41/40/39	44/43/42/42/41/40/39
Main body	Net dimensions <sup>5</sup> (W×H×D)	mm	840×204×840	840×204×840
	Packed dimensions (W×H×D)	mm	940×250×940	940×250×940
	Net/Gross weight	kg	18/20.8	18/20.8
Panel	Net dimensions <sup>6</sup> (W×H×D)	mm	950×53×950	950×53×950
	Packed dimensions (W×H×D)	mm	1030×95×1030	1030×95×1030
	Net/Gross weight	kg	5.6/8.0	5.6/8.0
Refrigerant type			R410A/R32	
Pipe connections	Liquid/Gas pipe	mm	Ø6.35/Ø12.7	Ø6.35/Ø12.7
	Drain pipe	mm	OD Ø25	

Model			MIH45Q4HN18	MIH56Q4HN18	MIH71Q4HN18
Power supply			1-phase, 220-240V, 50/60Hz		
Cooling <sup>1</sup>	Capacity	kW	4.5	5.6	7.1
		kBtu/h	15.4	19.1	24.2
	Power input	W	36.0	23.0	32.0
Heating <sup>2</sup>	Capacity	kW	5.0	6.3	8.0
		kBtu/h	17.1	21.5	27.3
	Power input	W	36.0	23.0	32.0
Air flow rate <sup>3</sup>	m <sup>3</sup> /h		910/840/770/701/631/561/491	840/791/741/692/642/593/543	1000/943/886/829/772/715/658
Sound pressure level <sup>4</sup>	dB(A)		37/35/34/32/30/29/27	33/32/31/30/29/28/27	37/36/34/33/31/30/28
Sound power level	dB(A)		52/51/49/47/45/43/40	49/48/47/47/46/45/44	52/51/50/48/47/45/44
Main body	Net dimensions <sup>5</sup> (W×H×D)	mm	840×204×840	840×204×840	840×204×840
	Packed dimensions (W×H×D)	mm	940×250×940	940×250×940	940×250×940
	Net/Gross weight	kg	18/20.8	19.5/22.4	19.5/22.4
Panel	Net dimensions <sup>6</sup> (W×H×D)	mm	950×53×950	950×53×950	950×53×950
	Packed dimensions (W×H×D)	mm	1030×95×1030	1030×95×1030	1030×95×1030
	Net/Gross weight	kg	5.6/8.0	5.6/8.0	5.6/8.0
Refrigerant type			R410A/R32		
Pipe connections	Liquid/Gas pipe	mm	Ø6.35/Ø12.7	Ø6.35/Ø12.7	Ø9.52/Ø15.9
	Drain pipe	mm	OD Ø25		

### Notes:

- Indoor temperature 27°C DB, 19°C WB; outdoor temperature 35°C DB; equivalent refrigerant piping length 7.5m with zero level difference.
- Indoor temperature 20°C DB; outdoor temperature 7°C DB, 6°C WB; equivalent refrigerant piping length 7.5m with zero level difference.
- Air flow rate are from the highest speed to the lowest speed, total 7 rates for each model.
- Sound pressure level is from highest level to lowest level, total 7 levels for each model. Sound pressure level is measured 1.5m below the unit in an anechoic chamber.
- The dimension is only the body size, excluding the size of the installation lug, connecting copper pipe, etc. For detailed dimensions, please refer to the installation manual.
- Exposed height of the panel after being installed on the ceiling.

# Specifications

## Four-Way Cassette

Model			MIH80Q4HN18	MIH90Q4HN18	MIH100Q4HN18
Power supply			1-phase, 220-240V, 50/60Hz		
Cooling <sup>1</sup>	Capacity	kW	8.0	9.0	10.0
		kBtu/h	27.3	30.7	34.1
	Power input	W	41.0	43.0	74.0
Heating <sup>2</sup>	Capacity	kW	9.0	10.0	11.2
		kBtu/h	30.7	34.1	38.2
	Power input	W	41.0	43.0	74.0
Air flow rate <sup>3</sup>	m <sup>3</sup> /h		1100/1019/939/858/777/697/616	1330/1239/1148/1057/965/874/783	1470/1360/1250/1141/1031/921/811
Sound pressure level <sup>4</sup>	dB(A)		42.5/40/38/36/34/32/30	38/37/35/34/32/31/29	43/41/40/38/36/35/33
Sound power level	dB(A)		57/55/53/51/49/47/45	55/54/52/51/50/48/47	58/57/55/53/51/49/47
Main body	Net dimensions <sup>5</sup> (W×H×D)	mm	840×204×840	840×246×840	840×246×840
	Packed dimensions (W×H×D)	mm	940×250×940	940×295×940	940×295×940
	Net/Gross weight	kg	19.5/22.4	21.5/25.4	21.5/25.4
Panel	Net dimensions <sup>6</sup> (W×H×D)	mm	950×53×950	950×53×950	950×53×950
	Packed dimensions (W×H×D)	mm	1030×95×1030	1030×95×1030	1030×95×1030
	Net/Gross weight	kg	5.6/8.0	5.6/8.0	5.6/8.0
Refrigerant type			R410A/R32		
Pipe connections	Liquid/Gas pipe	mm	Ø9.52/Ø15.9	Ø9.52/Ø15.9	Ø9.52/Ø15.9
	Drain pipe	mm	OD Ø25		

Model			MIH112Q4HN18	MIH140Q4HN18	MIH160Q4HN18	MIH180Q4HN18
Power supply			1-phase, 220-240V, 50/60Hz			
Cooling <sup>1</sup>	Capacity	kW	11.2	14.0	16.0	18.0
		kBtu/h	38.2	47.8	54.6	61.4
	Power input	W	61.0	118.0	110.0	145.0
Heating <sup>2</sup>	Capacity	kW	12.5	16.0	18.0	20.0
		kBtu/h	42.7	54.6	61.4	68.2
	Power input	W	61.0	118.0	110.0	145.0
Air flow rate <sup>3</sup>	m <sup>3</sup> /h		1600/1497/1393/1290/1186/1083/979	1900/1787/1673/1560/1446/1333/1219	2100/1900/1760/1630/1500/1380/1270	2300/2140/1960/1770/1600/1430/1270
Sound pressure level <sup>4</sup>	dB(A)		41/40/38/37/36/34/33	47.5/46/44/42/40/38/36.5	48/46/44/43/41/39/37	52/49/47/45/42/39/38
Sound power level	dB(A)		57/56/55/54/53/52/51	64/63/61/60/58/56/54	57/56/54/52/50/47/46	60/58/56/54/52/49/46
Main body	Net dimensions <sup>5</sup> (W×H×D)	mm	840×288×840	840×288×840	950×300×950	950×300×950
	Packed dimensions (W×H×D)	mm	940×335×940	940×335×940	1050×350×1050	1050×350×1050
	Net/Gross weight	kg	24/27.7	24/27.7	32.6/37.2	32.7/37.3
Panel	Net dimensions <sup>6</sup> (W×H×D)	mm	950×53×950	950×53×950	1050×55×1050	1050×55×1050
	Packed dimensions (W×H×D)	mm	1030×95×1030	1030×95×1030	1115×100×1115	1115×100×1115
	Net/Gross weight	kg	5.6/8.0	5.6/8.0	7.4/9.7	7.4/9.7
Refrigerant type			R410A/R32			
Pipe connections	Liquid/Gas pipe	mm	Ø9.52/Ø15.9	Ø9.52/Ø15.9	Ø9.52/Ø15.9	Ø9.52/Ø19.1
	Drain pipe	mm	OD Ø25			

### Notes:

- Indoor temperature 27°C DB, 19°C WB; outdoor temperature 35°C DB; equivalent refrigerant piping length 7.5m with zero level difference.
- Indoor temperature 20°C DB; outdoor temperature 7°C DB, 6°C WB; equivalent refrigerant piping length 7.5m with zero level difference.
- Air flow rate are from the highest speed to the lowest speed, total 7 rates for each model.
- Sound pressure level is from highest level to lowest level, total 7 levels for each model. Sound pressure level is measured 1.5m below the unit in an anechoic chamber.
- The dimension is only the body size, excluding the size of the installation lug, connecting copper pipe, etc. For detailed dimensions, please refer to the installation manual.
- Exposed height of the panel after being installed on the ceiling.

# Specifications

## Arc Duct

Model			MIH15T3HN18	MIH22T3HN18
Power supply			1-phase, 220-240V, 50/60Hz	
Cooling <sup>1</sup>	Capacity	kW	1.5	2.2
		kBtu/h	5.1	7.5
	Power input	W	21	22
Heating <sup>2</sup>	Capacity	kW	1.8	2.5
		kBtu/h	6.1	8.5
	Power input	W	21	22
Air flow rate <sup>3</sup>	m <sup>3</sup> /h	340/335/329/320/307/298/290		370/347/339/322/314/ 306/295
External static pressure <sup>4</sup>	Pa	10 (10-50)		
Sound pressure level <sup>5</sup>	dB(A)	27/26/25.5/24.5/23.5/ 22.5/22		28/27.5/26.5/25.5/24.5/23.5/22.0
Sound power level	dB(A)	43.5/43/42.5/42/41.5/41/40		46/45/44/43/42/41/40
Unit	Net dimensions <sup>6</sup> (W×H×D)	mm	550×199×450	
	Packed dimensions (W×H×D)	mm	715×255×525	
	Net/Gross weight	kg	11.5/13.5	
Refrigerant type			R410A/R32	
Pipe connections	Liquid/Gas pipe	mm	Ø6.35/Ø12.7	
	Drain pipe	mm	OD Ø25	

Model			MIH28T3HN18	MIH36T3HN18	MIH45T3HN18
Power supply			1-phase, 220-240V, 50/60Hz		
Cooling <sup>1</sup>	Capacity	kW	2.8	3.6	4.5
		kBtu/h	9.6	12.3	15.4
	Power input	W	28	31	43
Heating <sup>2</sup>	Capacity	kW	3.2	4	5
		kBtu/h	10.9	13.7	17.1
	Power input	W	28	31	43
Air flow rate <sup>3</sup>	m <sup>3</sup> /h	460/431/413/380/351/ 323/300	605/557/508/453/414/ 365/320	800/770/701/629/557/ 506/435	
External static pressure <sup>4</sup>	Pa	10 (10-50)			
Sound pressure level <sup>5</sup>	dB(A)	30/29.5/28.5/27.5/26/24.5/22	30/29.5/28.5/27.5/ 26.5/25.5/25	33/32.5/32/30.5/29/ 27.5/26	
Sound power level	dB(A)	50.5/49/47/45.5/43.5/42/40	50.5/49.5/48/47/45.5/44.5/43	52/50.5/49/47.5/46/44.5/43	
Unit	Net dimensions <sup>6</sup> (W×H×D)	mm	550×199×450	700×199×450	900×199×450
	Packed dimensions (W×H×D)	mm	715×255×525	865×255×525	1065×255×525
	Net/Gross weight	kg	11.5/13.5	13.0/15.5	16.5/19.5
Refrigerant type			R410A/R32		
Pipe connections	Liquid/Gas pipe	mm	Ø6.35/Ø12.7		
	Drain pipe	mm	OD Ø25		

### Notes:

- Indoor temperature 27°C DB, 19°C WB; outdoor temperature 35°C DB; equivalent refrigerant piping length 7.5m with zero level difference.
- Indoor temperature 20°C DB; outdoor temperature 7°C DB, 6°C WB; equivalent refrigerant piping length 7.5m with zero level difference.
- Fan motor speed and air flow rate are from the highest speed to the lowest speed, total 7 rates for each model.
- Stable operation external static pressure range. (Note: setting external static pressure outside the unit's optimal static pressure range may lead to higher noise levels and lower airflow rate. For the optimal external static pressure range refer to the unit's installation manual.)
- Sound pressure level is from highest level to lowest level, total 7 levels for each model. Sound pressure level is measured 1.5m below the unit in an anechoic chamber.
- The dimension is only the body size, excluding the size of the installation lug, connecting copper pipe, etc. For detailed dimensions, please refer to the installation manual.

# Specifications

## Arc Duct

Model			MIH56T3HN18	MIH71T3HN18	MIH80T3HN18
Power supply			1-phase, 220-240V, 50/60Hz		
Cooling <sup>1</sup>	Capacity	kW	5.6	7.1	8
		kBtu/h	19.1	24.2	27.3
	Power input	W	58	65	108
Heating <sup>2</sup>	Capacity	kW	6.3	8	9
		kBtu/h	21.5	27.3	30.7
	Power input	W	58	65	108
Air flow rate <sup>3</sup>	m <sup>3</sup> /h	900/800/761/682/603/ 549/470	1145/1033/957/860/763/671/580	1400/1327/1249/1175/1095/1026/960	
External static pressure <sup>4</sup>	Pa	10 (10-50)		20(10-80)	
Sound pressure level <sup>5</sup>	dB(A)	36/34.5/33.5/32.5/ 31/29/27	37/35/34/32.5/31/30/29	36.5/35.5/34.5/33/ 32/31.5/30.5	
Sound power level	dB(A)	56/54/52/50/48/46/44	57/55.5/54/52/50.5/49/47	57/56/54.5/53.5/52/51/49.5	
Unit	Net dimensions <sup>6</sup> (W×H×D)	mm	900×199×450	1100×199×450	1600×199×450
	Packed dimensions (W×H×D)	mm	1065×255×525	1300×255×525	1780×250×525
	Net/Gross weight	kg	16.5/19.5	20/23.5	28/32.5
Refrigerant type			R410A/R32		
Pipe connections	Liquid/Gas pipe	mm	Ø6.35/Ø12.7	Ø9.52/Ø15.9	Ø9.52/Ø15.9
	Drain pipe	mm	OD Ø25		

Model			MIH90T3HN18	MIH112T3HN18
Power supply			1-phase, 220-240V, 50/60Hz	
Cooling <sup>1</sup>	Capacity	kW	9	11.2
		kBtu/h	30.7	38.2
	Power input	W	108	128
Heating <sup>2</sup>	Capacity	kW	10	12.5
		kBtu/h	34.1	42.7
	Power input	W	108	128
Air flow rate <sup>3</sup>	m <sup>3</sup> /h	1400/1327/1249/1175/1095/1026/960	1620/1522/1433/1343/1254/1170/1080	
External static pressure <sup>4</sup>	Pa	20(10-80)		
Sound pressure level <sup>5</sup>	dB(A)	36.5/35.5/34/33/ 32/31.5/30.5	39.5/38/36.5/35/34/ 32.5/31.5	
Sound power level	dB(A)	57/56/54.5/53.5/52/51/49.5	60.5/59/57.5/55.5/54/52.5/50.5	
Unit	Net dimensions <sup>6</sup> (W×H×D)	mm	1600×199×450	1600×199×450
	Packed dimensions (W×H×D)	mm	1780×250×525	1780×250×525
	Net/Gross weight	kg	28/32.5	
Refrigerant type			R410A/R32	
Pipe connections	Liquid/Gas pipe	mm	Ø9.52/Ø15.9	
	Drain pipe	mm	OD Ø25	

### Notes:

- Indoor temperature 27°C DB, 19°C WB; outdoor temperature 35°C DB; equivalent refrigerant piping length 7.5m with zero level difference.
- Indoor temperature 20°C DB; outdoor temperature 7°C DB, 6°C WB; equivalent refrigerant piping length 7.5m with zero level difference.
- Fan motor speed and air flow rate are from the highest speed to the lowest speed, total 7 rates for each model.
- Stable operation external static pressure range. (Note: setting external static pressure outside the unit's optimal static pressure range may lead to higher noise levels and lower airflow rate. For the optimal external static pressure range refer to the unit's installation manual.)
- Sound pressure level is from highest level to lowest level, total 7 levels for each model. Sound pressure level is measured 1.5m below the unit in an anechoic chamber.
- The dimension is only the body size, excluding the size of the installation lug, connecting copper pipe, etc. For detailed dimensions, please refer to the installation manual.

## Specifications

### Medium Static Pressure Duct

Model			MIH15T2HN18	MIH22T2HN18	MIH28T2HN18
Power supply			1-phase, 220-240V, 50/60Hz		
Cooling <sup>1</sup>	Capacity	kW	1.5	2.2	2.8
		kBtu/h	5.1	7.5	9.6
	Power input	W	33	36	40
Heating <sup>2</sup>	Capacity	kW	1.8	2.5	3.2
		kBtu/h	6.1	8.5	10.9
	Power input	W	33	36	40
Air flow rate <sup>3</sup>	m <sup>3</sup> /h	470/438/407/375/343/312/280	500/467/433/400/367/333/300	540/503/467/430/393/357/320	
External static pressure <sup>4</sup>	Pa	30 (10-160)			
Sound pressure level <sup>5</sup>	dB(A)	26.5/26/25/24/23/22.5/22	26.5/26/25/24/23/22.5/22	26.5/26/25/24/23/22.5/22	
Sound power level	dB(A)	46/44.5/43/41.5/40/38.5/37	47/45.5/44/42.5/41/39.5/38	47/45.5/44/42.5/41/39.5/38	
Unit	Net dimensions <sup>6</sup> (W×H×D)	mm	600×245×750		
	Packed dimensions (W×H×D)	mm	765×305×885		
	Net/Gross weight	kg	18.5/21	18.5/21	18.5/21
Refrigerant type			R410A/R32		
Pipe connections	Liquid/Gas pipe	mm	Ø6.35/Ø12.7		
	Drain pipe	mm	OD Ø25		

Model			MIH36T2HN18	MIH45T2HN18	MIH56T2HN18
Power supply			1-phase, 220-240V, 50/60Hz		
Cooling <sup>1</sup>	Capacity	kW	3.6	4.5	5.6
		kBtu/h	12.3	15.4	19.1
	Power input	W	50	70	70
Heating <sup>2</sup>	Capacity	kW	4	5	6.3
		kBtu/h	13.7	17.1	21.5
	Power input	W	50	70	70
Air flow rate <sup>3</sup>	m <sup>3</sup> /h	575/535/495/455/415/375/335	665/623/580/538/495/453/410	970/904/838/773/707/641/575	
External static pressure <sup>4</sup>	Pa	30 (10-160)			
Sound pressure level <sup>5</sup>	dB(A)	29/28/27/26/25/23/22	33/32/29.5/28/26.5/25/24	33/32/31/30/27.5/26/25	
Sound power level	dB(A)	50/48.5/47/45/43/41/39	53/51/49/47/45/43/41	55/53/51/49/47/45/43	
Unit	Net dimensions <sup>6</sup> (W×H×D)	mm	600×245×750		
	Packed dimensions (W×H×D)	mm	765×305×885		
	Net/Gross weight	kg	18.5/21	19.5/22	24/27.5
Refrigerant type			R410A/R32		
Pipe connections	Liquid/Gas pipe	mm	Ø6.35/Ø12.7		
	Drain pipe	mm	OD Ø25		

#### Notes:

- Indoor temperature 27°C DB, 19°C WB; outdoor temperature 35°C DB; equivalent refrigerant piping length 7.5m with zero level difference.
- Indoor temperature 20°C DB; outdoor temperature 7°C DB, 6°C WB; equivalent refrigerant piping length 7.5m with zero level difference.
- Fan motor speed and air flow rate are from the highest speed to the lowest speed, total 7 rates for each model.
- Stable operation external static pressure range. (Note: setting external static pressure outside the unit's optimal static pressure range may lead to higher noise levels and lower airflow rate. For the optimal external static pressure range refer to the unit's installation manual.)
- Sound pressure level is from highest level to lowest level, total 7 levels for each model. Sound pressure level is measured 1.5m below the unit in a semi-anechoic chamber.
- The dimension is only the body size, excluding the size of the installation lug, connecting copper pipe, etc. For detailed dimensions, please refer to the installation manual.

## Specifications

### Medium Static Pressure Duct

Model			MIH71T2HN18	MIH80T2HN18	MIH90T2HN18
Power supply			1-phase, 220-240V, 50/60Hz		
Cooling <sup>1</sup>	Capacity	kW	7.1	8	9
		kBtu/h	24.2	27.3	30.7
	Power input	W	96	102	110
Heating <sup>2</sup>	Capacity	kW	8	9	10
		kBtu/h	27.3	30.7	34.1
	Power input	W	96	102	110
Air flow rate <sup>3</sup>	m <sup>3</sup> /h	1150/1068/986/904/822/740/660	1355/1263/1172/1080/988/897/805	1420/1323/1225/1128/1030/933/835	
External static pressure <sup>4</sup>	Pa	30 (10-160)			
Sound pressure level <sup>5</sup>	dB(A)	35/33.5/32/30.5/29/27.5/26	37/35.5/34/32.5/31/29.5/28	37/35.5/34/32.5/31/29.5/28	
Sound power level	dB(A)	58/56/54/51.5/48/47/45	59/57/55/53/51/49/47	59/57/55/53/50.5/48/46	
Unit	Net dimensions <sup>6</sup> (W×H×D)	mm	800×245×750		
	Packed dimensions (W×H×D)	mm	965×305×885		
	Net/Gross weight	kg	25/28.5	30/34.0	31/35.0
Refrigerant type			R410A/R32		
Pipe connections	Liquid/Gas pipe	mm	Ø9.52/Ø15.9		
	Drain pipe	mm	OD Ø25		

Model			MIH112T2HN18	MIH140T2HN18	MIH160T2HN18
Power supply			1-phase, 220-240V, 50/60Hz		
Cooling <sup>1</sup>	Capacity	kW	11.2	14	16
		kBtu/h	38.2	47.8	54.6
	Power input	W	138	172	210
Heating <sup>2</sup>	Capacity	kW	12.5	16	18
		kBtu/h	42.7	54.6	61.4
	Power input	W	138	172	210
Air flow rate <sup>3</sup>	m <sup>3</sup> /h	1950/1817/1683/1550/1417/1283/1150	2105/1971/1837/1703/1568/1434/1300	2350/2160/2015/1871/1776/1533/1400	
External static pressure <sup>4</sup>	Pa	40 (10-160)			
Sound pressure level <sup>5</sup>	dB(A)	39/37/35/33/31/29/28	40/38/36/34/32/30/29	42/40/38/36/34/33/31	
Sound power level	dB(A)	60/58/56.5/55/53.5/52/50	64/62/61.5/59.5/57.5/55/53	65/63/61/58.5/56.5/54/52	
Unit	Net dimensions <sup>6</sup> (W×H×D)	mm	1400×245×750		
	Packed dimensions (W×H×D)	mm	1565×305×885		
	Net/Gross weight	kg	37/42.0	39/44.0	39/44.0
Refrigerant type			R410A/R32		
Pipe connections	Liquid/Gas pipe	mm	Ø9.52/Ø15.9		
	Drain pipe	mm	OD Ø25		

#### Notes:

- Indoor temperature 27°C DB, 19°C WB; outdoor temperature 35°C DB; equivalent refrigerant piping length 7.5m with zero level difference.
- Indoor temperature 20°C DB; outdoor temperature 7°C DB, 6°C WB; equivalent refrigerant piping length 7.5m with zero level difference.
- Fan motor speed and air flow rate are from the highest speed to the lowest speed, total 7 rates for each model.
- Stable operation external static pressure range. (Note: setting external static pressure outside the unit's optimal static pressure range may lead to higher noise levels and lower airflow rate. For the optimal external static pressure range refer to the unit's installation manual.)
- Sound pressure level is from highest level to lowest level, total 7 levels for each model. Sound pressure level is measured 1.5m below the unit in a semi-anechoic chamber.
- The dimension is only the body size, excluding the size of the installation lug, connecting copper pipe, etc. For detailed dimensions, please refer to the installation manual.

# Specifications

## High Static Pressure Duct

Model name			MIH56T1HN18	MIH71T1HN18	MIH80T1HN18	MIH90T1HN18
Power supply			1-phase, 220-240V, 50/60Hz			
Cooling <sup>1</sup>	Capacity	kW	5.6	7.1	8	9
		kBut/h	19.1	24.2	27.3	30.7
	Input	W	159	159	159	196
Heating <sup>2</sup>	Capacity	kW	6.3	8	9	10
		kBut/h	21.5	27.3	30.7	34.1
	Input	W	159	159	159	196
Airflow rate <sup>3</sup>		m <sup>3</sup> /h	1360/1281/1201/1122/ 1043/963/884	1360/1281/1201/1122/ 1043/963/884	1360/1281/1201/1122/ 1043/963/884	1500/1413/1325/1238/ 1150/1063/975
External static pressure <sup>4</sup>		Pa	80(0-250)			
Sound pressure level <sup>5</sup>		dB(A)	39/38/36/35/33/32/30	39/38/36/35/33/32/30	39/38/36/35/33/32/30	40/39/37/36/34/33/31
Sound power level		dB(A)	59/56/54/53/51/49/47	59/56/54/53/51/49/47	59/56/54/53/51/49/47	63/60/58/56/54/52/50
Unit	Net dimensions <sup>6</sup> (WxHxD)	mm	1050x299x750			
	Packed dimensions (WxHxD)	mm	1215x359x890			
	Net/Gross weight	kg	35/38.5	35/38.5	35/38.5	35/38.5
Refrigerant type			R410A/R32	R410A/R32	R410A/R32	R410A/R32
Pipe connections	Liquid/Gas pipe	mm	Φ6.35/Φ12.7			
	Drain pipe	mm	OD Φ25			

Model name			MIH112T1HN18	MIH125T1HN18	MIH140T1HN18	MIH160T1HN18
Power supply			1-phase, 220-240V, 50/60Hz			
Cooling <sup>1</sup>	Capacity	kW	11.2	12.5	14	16
		kBut/h	38.2	42.7	47.8	54.6
	Input	W	248	252	284	339
Heating <sup>2</sup>	Capacity	kW	12.5	14	16	18
		kBut/h	42.7	47.8	54.6	61.4
	Input	W	248	252	284	339
Airflow rate <sup>3</sup>		m <sup>3</sup> /h	2140/2015/1890/1766/ 1641/1516/1391	2150/2025/1899/1774/ 1649/1523/1398	2400/2260/2120/1980/ 1840/1700/1560	2600/2448/2297/2145/ 1993/1842/1690
External static pressure <sup>4</sup>		Pa	80(0-250)	100(0-250)		
Sound pressure level <sup>5</sup>		dB(A)	41/40/38/37/35/34/32	41/40/39/37/36/35/33	43/42/40/39/37/36/34	44/43/41/40/38/37/35
Sound power level		dB(A)	63/61/59/57/56/54/52	66/64/62/60/58/56/54	67/64/62/60/58/57/55	68/66/64/62/60/59/57
Unit	Net dimensions <sup>6</sup> (WxHxD)	mm	1400x299x750			
	Packed dimensions (WxHxD)	mm	1565x359x890			
	Net/Gross weight	kg	44.5/48.5	46.5/50.5	46.5/50.5	46.5/50.5
Refrigerant type			R410A/R32	R410A/R32	R410A/R32	R410A/R32
Pipe connections	Liquid/Gas pipe	mm	Φ9.52/Φ15.9			
	Drain pipe	mm	OD Φ25			

1. Indoor temperature 27°C DB, 19°C WB; outdoor temperature 35°C DB; equivalent refrigerant piping length 7.5m with zero level difference.

2. Indoor temperature 20°C DB; outdoor temperature 7°C DB, 6°C WB; equivalent refrigerant piping length 7.5m with zero level difference.

3. Fan motor speed and air flow rate are from the highest speed to the lowest speed, total 7 rates for each model.

4. Stable operation external static pressure range. (Note: setting external static pressure outside the unit's optimal static pressure range may lead to higher noise levels and lower airflow rate. For the optimal external static pressure range refer to the unit's installation manual.)

5. Sound pressure level is from highest level to lowest level, total 7 levels for each model. Sound pressure level is measured 1.4m below the unit in a anechoic chamber.

6. The dimension is only the body size, excluding the size of the installation lug, connecting copper pipe, etc. For detailed dimensions, please refer to the installation manual.

7. All specifications are measured at standard external static pressure.

# Specifications

## High Static Pressure Duct

Model name			MIH200T1HN18	MIH224T1HN18	MIH252T1HN18	MIH280T1HN18
Power supply			1-phase, 220-240V, 50/60Hz			
Cooling <sup>1</sup>	Capacity	kW	20	22.4	25.2	28
		kBut/h	68.3	76.5	86.0	95.6
	Input	W	780	780	780	780
Heating <sup>2</sup>	Capacity	kW	22.5	25	26	31.5
		kBut/h	76.8	85.3	88.7	107.5
	Input	W	780	780	780	780
Airflow rate <sup>3</sup>		m <sup>3</sup> /h	4700/4387/4073/3760/ 3447/3133/2820	4700/4387/4073/3760/ 3447/3133/2820	4700/4387/4073/3760/ 3447/3133/2820	4700/4387/4073/3760/ 3447/3133/2820
External static pressure <sup>4</sup>		Pa	200(0-400)			
Sound pressure level <sup>5</sup>		dB(A)	51/50/48/46/44/43/42	51/50/48/46/44/43/42	51/50/48/46/44/43/42	51/50/48/46/44/43/42
Sound power level		dB(A)	74/72/70/68/66/64/62	74/72/70/68/66/64/62	74/72/70/68/66/64/62	74/72/70/68/66/64/62
Unit	Net dimensions <sup>6</sup> (WxHxD)	mm	1300x580x900			
	Packed dimensions (WxHxD)	mm	1530x730x1060			
	Net/Gross weight	kg	125/150	125/150	125/150	125/150
Refrigerant type			R410A/R32	R410A/R32	R410A/R32	R410A/R32
Pipe connections	Liquid/Gas pipe	mm	Φ9.52/Φ19.1			Φ12.7/Φ22.2
	Drain pipe	mm	OD Φ32			

Model name			MIH335T1HN18	MIH400T1HN18	MIH450T1HN18	MIH560T1HN18
Power supply			1-phase, 220-240V, 50/60Hz			
Cooling <sup>1</sup>	Capacity	kW	33.5	40	45	56
		kBut/h	114.3	136.5	153.6	191.1
	Input	W	810	1850	1850	2030
Heating <sup>2</sup>	Capacity	kW	38	45	56	63
		kBut/h	129.7	153.6	191.1	215.0
	Input	W	810	1850	1850	2030
Airflow rate <sup>3</sup>		m <sup>3</sup> /h	4700/4387/4073/3760/ 3447/3133/2820	7500/7000/6500/6000/ 5500/5000/4500	7500/7000/6500/6000/ 5500/5000/4500	8400/7840/7280/6720/ 6160/5600/5040
External static pressure <sup>4</sup>		Pa	200(0-400)	300(0-400)		
Sound pressure level <sup>5</sup>		dB(A)	52/51/49/48/46/44/43	58/56/54/52/50/49/48	58/56/54/52/50/49/48	59/58/56/54/53/51/49
Sound power level		dB(A)	74/72/70/68/66/63/61	79/78/76/74/72/70/67	79/78/76/74/72/70/67	81/80/77/75/73/71/69
Unit	Net dimensions <sup>6</sup> (WxHxD)	mm	1300x580x900	1850x580x900		
	Packed dimensions (WxHxD)	mm	1530x730x1060	2080x730x1060		
	Net/Gross weight	kg	128/153	166/204	166/204	170/208
Refrigerant type			R410A/R32	R410A/R32	R410A/R32	R410A/R32
Pipe connections	Liquid/Gas pipe	mm	Φ12.7/Φ25.4	Φ12.7/Φ25.4	Φ15.9/Φ28.6	
	Drain pipe	mm	OD Φ32			

1. Indoor temperature 27°C DB, 19°C WB; outdoor temperature 35°C DB; equivalent refrigerant piping length 7.5m with zero level difference.

2. Indoor temperature 20°C DB; outdoor temperature 7°C DB, 6°C WB; equivalent refrigerant piping length 7.5m with zero level difference.

3. Fan motor speed and air flow rate are from the highest speed to the lowest speed, total 7 rates for each model.

4. Stable operation external static pressure range. (Note: setting external static pressure outside the unit's optimal static pressure range may lead to higher noise levels and lower airflow rate. For the optimal external static pressure range refer to the unit's installation manual.)

5. Sound pressure level is from highest level to lowest level, total 7 levels for each model. Sound pressure level is measured 1.4m below the unit in a anechoic chamber.

6. The dimension is only the body size, excluding the size of the installation lug, connecting copper pipe, etc. For detailed dimensions, please refer to the installation manual.

7. All specifications are measured at standard external static pressure.

# Specifications

## Wall Mounted

Model			MIH15GHN18	MIH22GHN18	MIH28GHN18	MIH36GHN18
Power supply			1-phase, 220-240V, 50/60Hz			
Cooling <sup>1</sup>	Capacity	kW	1.5	2.2	2.8	3.6
		kBtu/h	5.1	7.5	9.6	12.3
	Power input	W	18	21	24	27
Heating <sup>2</sup>	Capacity	kW	1.7	2.4	3.2	4
		kBtu/h	5.8	8.2	10.9	13.6
	Power input	W	18	21	24	27
Air flow rate <sup>3</sup>		m <sup>3</sup> /h	460/440/420/400/380/360/340	500/470/440/410/390/370/340	540/510/470/430/400/370/340	580/540/500/460/420/380/340
Sound pressure level <sup>4</sup>		dB(A)	32/31/30/29/28/27	33/32/31/30/29/28/27	35/34/33/32/31/30/28	37/36/34/33/31/30/28
Sound power level		dB(A)	45/44/43/42/41/40	46/45/44/43/42/41/40	50/49/48/47/46/44/42	54/53/51/50/48/46/44
Unit	Net dimensions <sup>5</sup> (W×H×D)	mm	750 × 295 × 265	750 × 295 × 265	750 × 295 × 265	750 × 295 × 265
	Packed dimensions (W×H×D)	mm	875×385×360	875×385×360	875×385×360	875×385×360
	Net/Gross weight	kg	9/11.5	9/11.5	10/12.5	10/12.5
Refrigerant type			R410A/R32			
Pipe connections	Liquid/Gas pipe	mm	Ø6.35/Ø12.7	Ø6.35/Ø12.7	Ø6.35/Ø12.7	Ø6.35/Ø12.7
	Drain pipe	mm	OD Ø16	OD Ø16	OD Ø16	OD Ø16

Model			MIH45GHN18	MIH56GHN18	MIH71GHN18	MIH80GHN18
Power supply			1-phase, 220-240V, 50/60Hz			
Cooling <sup>1</sup>	Capacity	kW	4.5	5.6	7.1	8
		kBtu/h	15.4	19.1	24.2	27.3
	Power input	W	30	40	50	65
Heating <sup>2</sup>	Capacity	kW	5	6.3	8	9
		kBtu/h	17.1	21.5	27.3	30.7
	Power input	W	30	40	50	65
Air flow rate <sup>3</sup>		m <sup>3</sup> /h	720/670/620/560/510/460/410	860/780/700/620/550/480/410	1220/1120/1030/940/850/750/660	1380/1260/1140/1020/900/780/660
Sound pressure level <sup>4</sup>		dB(A)	37/35/33/32/31/30/29	41/39/37/35/33/31/29	44/42/40/38/36/34/32	45/43/41/39/37/35/32
Sound power level		dB(A)	54/52/50/49/48/46/44	56/54/52/50/48/46/44	58/56/54/52/50/48/46	60/57/55/53/50/48/46
Unit	Net dimensions <sup>5</sup> (W×H×D)	mm	950 × 295 × 265	950 × 295 × 265	1200×295×265	1200×295×265
	Packed dimensions (W×H×D)	mm	1075×385×360	1075×385×360	1315×385×360	1315×385×360
	Net/Gross weight	kg	11.5/14	11.5/14	15/18	15/18
Refrigerant type			R410A/R32			
Pipe connections	Liquid/Gas pipe	mm	Ø6.35/Ø12.7	Ø6.35/Ø12.7	Ø9.52/Ø15.9	Ø9.52/Ø15.9
	Drain pipe	mm	OD Ø16	OD Ø16	OD Ø16	OD Ø16

### Notes:

- Indoor temperature 27°C DB, 19°C WB; outdoor temperature 35°C DB; equivalent refrigerant piping length 7.5m with zero level difference.
- Indoor temperature 20°C DB; outdoor temperature 7°C DB, 6°C WB; equivalent refrigerant piping length 7.5m with zero level difference.
- Air flow rate are from the highest speed to the lowest speed, total 7 rates for each model.
- Sound pressure level is from highest level to lowest level, total 7 levels for each model. Sound pressure level is measured 0.8m below the unit in an anechoic chamber.
- The dimension is only the body size, excluding the size of the installation lug, connecting copper pipe, etc. For detailed dimensions, please refer to the installation manual.

# Specifications

## Floor Standing F3(concealed)

Model name			MIH22F3HN18	MIH28F3HN18	MIH36F3HN18	MIH45F3HN18	MIH56F3HN18	MIH71F3HN18	MIH80F3HN18	
Power supply			1-phase, 220-240V, 50/60Hz							
Cooling <sup>1</sup>	Capacity	kW	2.2	2.8	3.6	4.5	5.6	7.1	8	
		kBtu/h	7.5	9.6	12.3	15.4	19.1	24.2	27.3	
	Input	W	35	35	40	44	45	53	62	
Heating <sup>2</sup>	Capacity	kW	2.4	3.2	4.0	5.0	6.3	8.0	9.0	
		kBtu/h	8.2	10.9	13.7	17.1	21.5	27.3	30.7	
	Input	W	35	35	41	46	47	57	64	
External static pressure <sup>4</sup>		Pa	0-60							
Airflow rate <sup>3</sup>		m <sup>3</sup> /h	473/464/454/449/439/431/426		524/503/488/471/450/427/408		636/611/584/557/533/507/483		781/756/738/717/683/651/624	
Sound pressure level <sup>4</sup>		dB(A)	34.5/34/33.5/32.5/32/31/30.5		36.5/35.5/34.5/34/33/32/31		37/36/35/34/33/32/30		36.5/36/35/34/33.5/32.5/31.5	
Sound power level		dB(A)	49/48/48/47/47/46/46		51/50/49/48/47/46/46		52/51/50/49/48/47/46		51/51/50/49/48/48/47	
Unit	Net dimensions <sup>5</sup> (W×H×D)	mm	915×470×200				1133×470×200		1253×566×200	
	Packed dimensions (W×H×D)	mm	985×555×255				1205×555×255		1325×650×255	
	Net/Gross weight	kg	16.3/20.0		16.9/20.7		20.0/24.4		24.3/30.0	
Refrigerant type			R410A/R32							
Pipe connections	Liquid/Gas pipe	mm	Ø6.35/Ø12.7						Ø9.52/Ø15.9	
	Drain piping	mm	OD Ø18.5							

## Floor Standing F4/F5(Exposed)

Model name			MIH22F4HN18	MIH28F4HN18	MIH36F4HN18	MIH45F4HN18	MIH56F4HN18	MIH71F4HN18	MIH80F4HN18	
Power supply			1-phase, 220-240V, 50/60Hz							
Cooling <sup>1</sup>	Capacity	kW	2.2	2.8	3.6	4.5	5.6	7.1	8	
		kBtu/h	7.5	9.6	12.3	15.4	19.1	24.2	27.3	
	Input	W	35	35	40	44	45	53	62	
Heating <sup>2</sup>	Capacity	kW	2.4	3.2	4	5	6.3	8	9	
		kBtu/h	8.2	10.9	13.7	17.1	21.5	27.3	30.7	
	Input	W	35	35	41	46	47	57	64	
External static pressure <sup>4</sup>		Pa(F4)	0-10							
		Pa(F5)	0-10							
Airflow rate <sup>3</sup>		m <sup>3</sup> /h(F4)	507/490/482/466/449/450/435		532/512/501/483/466/435/414		689/663/639/608/575/560/526		934/904/888/860/821/786/764	
		m <sup>3</sup> /h(F5)	498/486/475/464/453/441/430		508/491/474/458/441/424/407		692/665/637/610/582/555/528		811/785/759/732/706/680/653	
Sound pressure level <sup>4</sup>		dB(A)(F4)	36/35/34.5/34/33/32.5/32		38/37/36/35/34/33/32		43/42/41/40/39/38/37/36		41.5/41/40/39/38/37/36	
		dB(A)(F5)	32.5/32/31.5/31/30.5/30/29		35/34/33/32/31/30/29		38/37/36/35/34/32.5/31.5		35/34.5/34/33/32.5/32/31	
Sound power level		dB(A)(F4)	52/51/51/50/50/49/49		52/52/51/50/49/48/47		55/54/54/53/52/51/51		53/52/52/52/51/51/50	
		dB(A)(F5)	51/50/49/49/48/48/48		51/50/49/48/47/47/46		53/53/52/51/50/49/48		51/50/50/50/49/49/48	
Unit	Net dimensions <sup>5</sup> (W×H×D)	mm(F4)	1020×495×200		1020×495×200		1240×495×200		1360×591×200	
		mm(F5)	1020×495×200		1020×495×200		1240×495×200		1360×591×200	
	Packed dimensions (W×H×D)	mm(F4)	1125×595×285		1125×595×285		1345×595×285		1465×695×285	
		mm(F5)	1125×595×285		1125×595×285		1345×595×285		1465×695×285	
	Net/Gross weight	kg(F4)	21.1/27.9		21.9/28.6		26.3/32.9		32.1/41.0	
	kg(F5)	21.1/26.8		21.9/27.6		26.3/32.4		32.1/39.4		
Refrigerant type			R410A/R32							
Pipe connections	Liquid/Gas pipe	mm	Ø6.35/Ø12.7						Ø9.52/Ø15.9	
	Drain piping	mm	OD Ø18.5							

### Notes:

- Indoor temperature 27°C DB, 19°C WB; outdoor temperature 35°C DB; equivalent refrigerant piping length 7.5m with zero level difference.
- Indoor temperature 20°C DB; outdoor temperature 7°C DB, 6°C WB; equivalent refrigerant piping length 7.5m with zero level difference.
- Fan motor speed and air flow rate are from the highest to the lowest, total 7 rates for each model.
- Sound pressure level is from highest level to lowest level, total 7 levels for each model. Sound pressure level is measured 1.5m below the unit in an anechoic chamber.
- Unit body dimensions given are the largest external dimensions of the unit, including hanger attachments.

# Specifications

## Ceiling&Floor

Model name		MIH36DLHN18	MIH45DLHN18	MIH56DLHN18	MIH71DLHN18	MIH80DLHN18	
Power supply		1-phase, 220-240V, 50/60Hz					
Cooling <sup>1</sup>	Capacity	kW	3.6	4.5	5.6	7.1	8
		kBut/h	12.3	15.4	19.1	24.2	27.3
Heating <sup>2</sup>	Capacity	kW	4	5	6.3	8	9
		kBut/h	13.7	17.1	21.5	27.3	30.7
Input	W	16	24	40	42	56	
Airflow rate <sup>3</sup>	m <sup>3</sup> /h	564/539/514/492/467/445/424	712/674/637/603/565/531/500	927/883/840/794/751/707/665	1128/1062/1024/926/860/791/729	1300/1218/1138/1057/982/904/824	
Sound pressure level <sup>4</sup>	dB(A)	32/30/29/28/27/26/25	36/35/34/33/32/31/30	43/41/40/38/36/34/33	43/40/39/37/35/34/33	45/44/42/40/38/36/34	
Sound power level	dB(A)	43/42/40/39/38/38/37	47/45/45/43/42/41/40	54/53/51/50/48/47/45	54/53/52/51/49/48/48	55/53/51/50/49/46/44	
Unit	Net dimensions <sup>5</sup> (WxHxD)	mm	1069x674x234			1284x674x234	
	Packed dimensions (WxHxD)	mm	1190x755x313			1405x755x323	
	Net/Gross weight	kg	24.7/29.5	24.7/29.5	24.7/29.5	29.8/34.8	29.8/34.8
Refrigerant type		R410A/R32					
Pipe connections	Liquid/Gas pipe	mm	Φ6.35/Φ12.7			Φ9.52/Φ15.9	
	Drain pipe	mm	OD Φ25				

Model name		MIH90DLHN18	MIH100DLHN18	MIH112DLHN18	MIH125DLHN18	MIH140DLHN18	
Power supply		1-phase, 220-240V, 50/60Hz					
Cooling <sup>1</sup>	Capacity	kW	9	10	11.2	12.5	14
		kBut/h	30.7	34.1	38.2	42.7	47.8
Heating <sup>2</sup>	Capacity	kW	10	11.2	12.5	14	16
		kBut/h	34.1	38.2	42.7	47.8	54.6
Input	W	75	50	65	95	140	
Airflow rate <sup>3</sup>	m <sup>3</sup> /h	1480/1397/1302/1218/1138/1056/979	1497/1469/1296/1200/1104/1015/918	1648/1530/1469/1292/1178/1067/956	2012/1879/1772/1649/1531/1469/1285	2206/2070/1937/1810/1677/1516/1402	
Sound pressure level <sup>4</sup>	dB(A)	48/47/46/44/42/40/37	42/40/39/37/35/33/32	44/42/41/39/37/35/33	49/48/46/44/42/40/38	51.5/50/48/46/44/42/40	
Sound power level	dB(A)	58/57/55/54/52/50/49	54/53/51/50/48/46/44	56/54/53/51/49/47/45	60/59/58/56/54/53/51	63/62/60/58/56/54/53	
Unit	Net dimensions <sup>5</sup> (WxHxD)	mm	1284x674x234	1649x674x234			
	Packed dimensions (WxHxD)	mm	1405x755x323	1770x755x323			
	Net/Gross weight	kg	29.8/34.8	36.4/42.7	36.4/42.7	36.4/42.7	36.4/42.7
Refrigerant type		R410A/R32					
Pipe connections	Liquid/Gas pipe	mm	Φ9.52/Φ15.9				
	Drain pipe	mm	OD Φ25				

### Notes:

- Indoor temperature 27°C DB, 19°C WB; outdoor temperature 35°C DB; equivalent refrigerant piping length 7.5m with zero level difference.
- Indoor temperature 20°C DB; outdoor temperature 7°C DB, 6°C WB; equivalent refrigerant piping length 7.5m with zero level difference.
- Fan motor speed and air flow rate are from the highest speed to the lowest speed, total 7 rates for each model.
- Sound pressure level is from highest level to lowest level, total 7 levels for each model. Sound pressure level is measured 1.5m below the unit in a semi-anechoic chamber.
- The dimension is only the body size, excluding the size of the installation lug, connecting copper pipe, etc. For detailed dimensions, please refer to the installation manual.

# Specifications

## Fresh Air Processing

Model name		MIH 200FAHN18	MIH 224FAHN18	MIH 252FAHN18	MIH 280FAHN18	MIH 335FAHN18	MIH 400FAHN18	MIH 450FAHN18	MIH 560FAHN18	
Power supply		1-phase, 220-240V, 50/60Hz								
Cooling <sup>1</sup>	Capacity	kW	20.0	22.4	25.2	28	33.5	40	45	56
		kBut/h	68.3	76.5	86.0	95.6	114.3	136.5	153.6	191.1
Heating <sup>2</sup>	Capacity	kW	12	13.7	16	18	22	26.5	27.8	39
		kBut/h	41.0	46.8	54.6	61.4	75.1	90.4	94.9	133.1
Input	W	425	425	480	540	550	900	900	1330	
Airflow rate <sup>3</sup>	m <sup>3</sup> /h	2500/2417/2333/2250/2167/2083/2000	2500/2417/2333/2250/2167/2083/2000	2800/2667/2533/2400/2267/2133/2000	3000/2833/2667/2500/2333/2167/2000	3200/3000/2800/2600/2400/2200/2000	4500/4217/3933/3650/3367/3083/2800	4500/4217/3933/3650/3367/3083/2800	6200/5833/5467/5100/4733/4367/4000	
External static pressure <sup>4</sup>	Pa	220(0-400)					300(0-400)			
Sound pressure level <sup>5</sup>	dB(A)	47/46/46/45/44/43/42	47/46/46/45/44/43/42	48/47/47/46/45/44/43	49/48/48/47/46/45/44	51/50/49/48/47/46/45	53/52/52/51/50/49/48	53/52/52/51/50/49/48	56/55/55/54/53/52/51	
Unit	Net dimensions <sup>6</sup> (WxHxD)	mm	1300x580x1050				1850x580x1050			
	Packed dimensions (WxHxD)	mm	1530x730x1060				2080x730x1060			
	Net/Gross weight	kg	117/142	117/142	117/142	117/142	121/146	161/198	161/198	164/201
Pipe connections	Liquid/Gas pipe	mm	Φ9.52/Φ19.1		Φ12.7/Φ22.2		Φ12.7/Φ25.4		Φ16/Φ28.6	
	Drain pipe	mm	OD Φ32							

### Notes:

- Indoor temperature 33°C DB, 28°C WB; outdoor temperature 33°C DB; equivalent refrigerant piping length 5m with zero level difference.
- Indoor temperature 0°C DB; outdoor temperature 0°C DB, -2.9°C WB; equivalent refrigerant piping length 5m with zero level difference.
- Fan motor speed and air flow rate are from the highest speed to the lowest speed, total 7 rates for each model.
- Stable operation external static pressure range. (Note: setting external static pressure outside the unit's optimal static pressure range may lead to higher noise levels and lower airflow rate. For the optimal external static pressure range refer to the unit's installation manual.)
- Sound pressure level is from highest level to lowest level, total 7 levels for each model. Sound pressure level is measured 1.5m below the unit in a semi-anechoic chamber.
- Unit body dimensions given are the largest external dimensions of the unit, including hanger attachments.
- All specifications are measured at standard external static pressure.
- Fresh air processing units are not allowed to be used in the same VRF system as other series of indoor units.
- When there are only fresh air processing units in the system, the combination ratio is 50-100%.

# Specifications

## Small Airflow Rate Fresh Air Processing

Model name		MIH90FASHN18	MIH140FASHN18	MIH160FASHN18	MIH224FASHN18	MIH280FASHN18	
Power supply		1-phase, 220-240V, 50/60Hz					
Cooling <sup>1</sup>	Capacity	kW	9.0	14.0	16.0	22.4	28.0
		kBut/h	30.7	47.8	54.6	76.5	95.6
	Input	W	80	165	185	320	400
Heating <sup>2</sup>	Capacity	kW	8.1	12.5	14.0	20.0	25.0
		kBut/h	27.6	42.7	47.8	68.3	85.3
	Input	W	80	165	185	320	400
Airflow rate <sup>3</sup>	m <sup>3</sup> /h	690/633/575/518/ 460/403/345	1100/1008/917/ 825/733/642/550	1230/1128/1025/ 923/820/718/615	1740/1595/1450/ 1305/1160/1015/870	2160/1980/1800/ 1620/1440/1260/1080	
External static pressure <sup>4</sup>	Pa	100 (0-300)	150 (0-300)	150 (0-300)	200 (0-300)	200 (0-300)	
Sound pressure level <sup>5</sup>	dB(A)	39/37.5/36/34/ 32.5/30.5/29	44.5/42.5/40/37/ 35/33/32	44.5/43/41/38/ 36/34/32.5	49/47/45/43/ 40/38/36	51/49/47/44/ 42/39/37	
Unit	Net dimensions <sup>6</sup> (WxHxD)	mm	1095x310x773	1095x310x773	1095x310x773	1445x310x773	1445x310x773
	Packed dimensions (WxHxD)	mm	1215x360x885	1215x360x885	1215x360x885	1645x360x885	1645x360x885
	Net/Gross weight	kg	37/41.5	40/43.5	40/43.5	54/59	54/59
Pipe connections	Liquid/Gas pipe	mm	Φ9.52/Φ15.9	Φ9.52/Φ15.9	Φ9.52/Φ15.9	Φ9.52/Φ19.1	Φ12.7/Φ22.2
	Drain pipe	mm	OD Φ25				

### Notes:

- Indoor temperature 33°C DB, 28°C WB; outdoor temperature 33°C DB; equivalent refrigerant piping length 7.5m with zero level difference.
- Indoor temperature 0°C DB; outdoor temperature 0°C DB, -2.9°C WB; equivalent refrigerant piping length 7.5m with zero level difference.
- Fan motor speed and air flow rate are from the highest speed to the lowest speed, total 7 rates for each model.
- Stable operation external static pressure range. (Note: setting external static pressure outside the unit's optimal static pressure range may lead to higher noise levels and lower airflow rate. For the optimal external static pressure range refer to the unit's installation manual.)
- Sound pressure level is from highest level to lowest level, total 7 levels for each model. Sound pressure level is measured 1.5m below the unit in a semi-anechoic chamber.
- Unit body dimensions given are the largest external dimensions of the unit, including hanger attachments.
- All specifications are measured at standard external static pressure.
- When fresh air processing units are installed together with standard indoor units, the total capacity of the fresh air processing units must not exceed 30% of the total capacity of the outdoor units and the total combination ratio must not exceed 100%.
- When there are only fresh air processing units in the system, the combination ratio is 50-100%.

# Specifications

## HRV

Sale Model		HRV-D200(C)	HRV-D300(C)	HRV-D400(C)	HRV-D500(C)	
Power supply		Ph-V-Hz	1-phase, 220-240V-50/60Hz			
Input power (H/M/L)(standard G4)		W	70/45/25	100/55/35	110/70/40	150/95/50
Input power (H/M/L)(F7+M5)		W	80/40/25	100/55/35	110/70/40	150/95/50
Nominal Temperature Efficiency (standard G4) (H/M/L)		%	79.5/81.1/83.5	75.5/78.8/82.5	77.7/79.0/81.3	80.6/82.2/85.5
Nominal Enthalpy Efficiency (standard G4) (H/M/L)		%	75.0/77.5/79.6	72.1/75.0/79.3	73.5/75.3/78.0	74.0/76.6/80.5
Nominal Temperature Efficiency (F7+M5) (H/M/L)		%	81.8/85.4/87.5	80.4/81.8/83.5	79.2/81.1/83.3	77.2/79.4/82.5
Nominal Enthalpy Efficiency (F7+M5) (H/M/L)		%	81.2/83.1/85.0	79.4/81.2/84.0	79.6/81.8/84.2	72.3/75.6/78.6
Current		A	0.64	0.84	0.97	1.2
Indoor external static pressure (H speed+ standard G4)		Pa	100	90	100	90
Fresh air external static pressure (H speed +F7+M5)		Pa	75	70	70	65
Discharge air external static pressure (H speed +F7+M5)		Pa	100	110	110	110
Nominal air flow		m <sup>3</sup> /h	200	300	400	500
Sound Pressure (H/M/L)		dB(A)	33/29.5/25.5	36.5/33.5/30	36.5/32/28	36/30.5/24.5
Sound Power		dB	45	48	48	50
Net dimension <sup>1</sup> (LxWxH)		mm	1195x784x272	1195x898x272	1276x1189x272	1311x1090x390
Packing size (LxWxH)		mm	1275x880x420	1275x994x420	1360x1284x420	1390x1244x540
Net/Gross weight		kg	51/68	57/74	72/92	62/85
Power supply wire	Wire qty.		3	3	3	3
	Code wire cross-section	mm <sup>2</sup>	2.5	2.5	2.5	2.5
Controller		Wired controller, Centralized controller, BMS gateway				
Fresh air	Fresh Air Diameter	mm	Φ144	Φ144	Φ198	Φ244
	Air drop	Pa	52	179	218	357

Sale Model		HRV-D800(C)	HRV-D1000(C)	HRV-D1500(C)	HRV-D2000(C)	
Power supply		Ph-V-Hz	1-phase, 220-240V-50/60Hz			
Input power (H/M/L)(standard G4)		W	320/170/80	380/210/100	680/320/200	950/500/230
Input power (H/M/L)(F7+M5)		W	320/170/80	420/230/100	680/320/200	950/500/230
Nominal Temperature Efficiency (standard G4) (H/M/L)		%	78.7/82.1/86.8	82.8/84.0/87.4	75.5/78.6/80.2	77.2/79.5/83.4
Nominal Enthalpy Efficiency (standard G4) (H/M/L)		%	72.3/75.4/79.0	76.0/76.0/80.1	69.4/71.2/74.8	74.7/77.0/80.6
Nominal Temperature Efficiency (F7+M5) (H/M/L)		%	74.9/77.1/80.8	75.4/78.0/81.4	83.8/84.6/86.2	78.8/80.5/83.4
Nominal Enthalpy Efficiency (F7+M5) (H/M/L)		%	71.1/74.4/78.0	67.3/71.1/75.0	74.6/76.2/78.8	71.1/75.0/79.6
Current		A	2.4	2.9	3.8	5.7
Indoor external static pressure (H speed+ standard G4)		Pa	140	160	180	200
Fresh air external static pressure (H speed +F7+M5)		Pa	100	110	150	160
Discharge air external static pressure (H speed +F7+M5)		Pa	155	145	180	180
Nominal air flow		m <sup>3</sup> /h	800	1000	1500	2000
Sound Pressure (H/M/L)		dB(A)	42/39/34	44/39/33.5	51.5/46.5/41.5	53/48.5/42.5
Sound Power		dB	55	54	69	70
Net dimension <sup>1</sup> (LxWxH)		mm	1311x1270x390	1311x1510x390	1740x1344x615	1811x1545x685
Packing size (LxWxH)		mm	1390x1424x540	1390x1670x540	1830x1520x770	1900x1720x845
Net/Gross weight		kg	77/101	85/112	168/200	195/235
Power supply wire	Wire qty.		3	3	3	3
	Code wire cross-section	mm <sup>2</sup>	2.5	2.5	2.5	2.5
Controller		Wired controller, Centralized controller, BMS gateway				
Fresh air	Fresh Air Diameter	mm	Φ244	Φ244	346x326	346x326
	Air drop	Pa	357	384	253	322

### Note:

- The dimension is only the body size, excluding the size of the installation lug, connecting copper pipe, etc. For detailed dimensions, please refer to the installation manual.